

# Apple II Reference Manual

January 1978

# APPLE II

Reference Manual

# APPLE II Reference Manual

January 1978

Apple Part No. 030-0004-00

APPLE Computer Inc.  
10260 Bandley Dr.  
Cupertino, CA  
95014

# APPLE II Reference Manual

## TABLE OF CONTENTS

<p><b>A. GETTING STARTED WITH YOUR APPLE II</b> ..... 1</p> <p>1. Unpacking ..... 1</p> <p>2. Warranty Registration Card ..... 1</p> <p>3. Check for Shipping Damage ..... 2</p> <p>4. Power Up ..... 2</p> <p>5. APPLE II Speaks Several Languages. 3</p> <p>6. APPLE Integer BASIC ..... 3</p> <p>7. Running Your First and Second Programs ..... 3</p> <p>8. Running 16K Startrek ..... 3</p> <p>9. Loading a Program Tape ..... 4</p> <p>10. Breakout and Color Demos Tapes .. 6</p> <p>11. Breakout and Color Demos Program Listings ..... 12</p> <p>12. How to Play Startrek ..... 14</p> <p>13. Loading HIRES Demo Tape ..... 15</p> <p><b>B. APPLE II INTEGER BASIC</b> ..... 17</p> <p>1. BASIC Commands ..... 18</p> <p>2. BASIC Operators ..... 19</p> <p>3. BASIC Functions ..... 22</p> <p>4. BASIC Statements ..... 23</p> <p>5. Special Control and Editing ..... 28</p> <p>6. Table A — Graphics Colors ..... 29</p> <p>7. Special Controls and Features ..... 30</p> <p>8. BASIC Error Messages ..... 32</p> <p>9. Simplified Memory Map ..... 33</p> <p>10. Data Read/Save Subroutines ..... 34</p> <p>11. Simple Tone Subroutines ..... 43</p> <p>12. High Resolution Graphics Subroutines and Listings ..... 46</p>	<p>13. Additional BASIC Program Examples ..... 55</p> <p>a. Rod's Color Pattern (4K) ..... 55</p> <p>b. Pong (4K) ..... 56</p> <p>c. Color Sketch (4K) ..... 57</p> <p>d. Mastermind (8K) ..... 59</p> <p>e. Biorhythm (4K) ..... 61</p> <p>f. Dragon Maze (4K) ..... 63</p> <p><b>C. APPLE II FIRMWARE</b> ..... 67</p> <p>1. System Monitor Commands ..... 68</p> <p>2. Control and Editing Characters .... 72</p> <p>3. Special Controls and Features ..... 74</p> <p>4. Annotated Monitor and Dis-assembler Listing ..... 76</p> <p>5. Binary Floating Point Package ..... 94</p> <p>6. Sweet 16 Interpreter Listing ..... 96</p> <p>7. 6502 Op Codes ..... 100</p> <p><b>D. APPLE II HARDWARE</b> ..... 106</p> <p>1. Getting Started with Your APPLE II Board ..... 107</p> <p>2. APPLE II Switching Power Supply . 110</p> <p>3. Interfacing with the Home TV .... 112</p> <p>4. Simple Serial Output ..... 114</p> <p>5. Interfacing the APPLE — Signals, Loading, Pin Connections ..... 122</p> <p>6. Memory — Options, Expansion, Map, Address ..... 133</p> <p>7. System Timing ..... 140</p> <p>8. Schematics ..... 141</p>
---	---

## GETTING STARTED WITH YOUR APPLE II

### Unpacking

Don't throw away the packing material. Save it for the unlikely event that you may need to return your Apple II for warranty repair. If you bought an Apple II Board only, see hardware section in this manual on how to get started. You should have received the following:

1. Apple II system including mother printed circuit board with specified amount of RAM memory and 8K of ROM memory, switching power supply, keyboard, and case assembly.
2. Accessories Box including the following:
  - a. This manual including warranty card.
  - b. Pair of Game Paddles
  - c. A.C. Power Cord
  - d. Cassette tape with "Breakout" on one side and "Color Demos" on the other side.
  - e. Cassette recorder interface cable (miniature phone jack type)
3. If you purchased a 16K or larger system, your accessory box should also contain:
  - a. 16K Startrek game cassette with High Resolution Graphics Demo ("HIRES") on the flipside.
  - b. Applesoft Floating Point Basic Language Cassette with an example program on the other side.
  - c. Applesoft reference manual
4. In addition other items such as a vinyl carrying case or hobby board peripheral may have been included if specifically ordered as "extras".

Notify your dealer or Apple Computer, Inc. immediately if you are missing any items.

### Warranty Registration Card

Fill this card out immediately and completely and mail to Apple in order to register for one year warranty and to be placed on owners club mailing list. Your Apple II's serial number is located on the bottom near the rear edge. Your model number is:

A2S00MMX

MM is the amount of memory you purchased. For Example:

A2S0008X

is an 8K Byte Apple II system.

### Check for Damage

Inspect the outside case of your Apple for shipping damage. Gently lift up on the top rear of the lid of the case to release the lid snaps and remove the lid. Inspect the inside. Nothing should be loose and rattling around. Gently press down on each integrated circuit to make sure that each is still firmly seated in its socket. Plug in your game paddles into the Apple II board at the socket marked "GAME I/O" at location J14. See hardware section of this manual for additional detail. The white dot on the connector should be face forward. Be careful as this connector is fragile. Replace the lid and press on the back top of it to re-snap it into place.

### Power Up

First, make sure that the power ON/OFF switch on the rear power supply panel on your Apple II is in the "OFF" position. Connect the A.C. power cord to the Apple and to a 3 wire 120 volt A.C. outlet. Make sure that you connect the third wire to ground if you have only a two conductor house wiring system. This ground is for your safety if there is an internal failure in the Apple power supply, minimizes the chance of static damage to the Apple, and minimizes RFI problems.

Connect a cable from the video output jack on the back of the Apple to a TV set with a direct video input jack. This type of set is commonly called a "Monitor". If your set does not have a direct video input, it is possible to modify your existing set. Write for Apple's Application note on this. Optionally you may connect the Apple to the antenna terminals of your TV if you use a modulator. See additional details in the hardware section of this manual under "Interfacing with the Home TV".

Now turn on the power switch on the back of the Apple. The indicator light (it's not a switch) on the keyboard should now be ON. If not, check A.C. connections. Press and release the "Reset" button on the keyboard. The following should happen: the Apple's internal speaker should beep, an asterisk ("\*") prompt character should appear at the lower left hand corner of your TV, and a flashing white square should appear just to the right of the asterisk. The rest of the TV screen will be made up of random text characters (typically question marks).

If the Apple beeps and garbage appears but you cannot see an "\*" and the cursor, the horizontal or vertical height settings on the TV need to be adjusted. Now depress and release the "ESC" key, then hold down the "SHIFT" key while depressing and releasing the P key. This should clear your TV screen to all black. Now depress and release the "RESET" key again. The "\*" prompt character and the cursor should return to the lower left of your TV screen.

## Apple Speaks Several Languages

The prompt character indicates which language your Apple is currently in. The current prompt character, an asterisk ("\*"), indicates that you are in the "Monitor" language, a powerful machine level language for advanced programmers. Details of this language are in the "Firmware" section of this manual.

## Apple Integer BASIC

Apple also contains a high level English oriented language called Integer BASIC, permanently in its ROM memory. To switch to this language hold down the "CTRL" key while depressing and releasing the "B" key. This is called a control-B function and is similar to the use of the shift key in that it indicates a different function to the Apple. Control key functions are not displayed on your TV screen but the Apple still gets the message. Now depress and release the "RETURN" key to tell Apple that you have finished typing a line on the keyboard. A right facing arrow (">") called a caret will now appear as the prompt character to indicate that Apple is now in its Integer BASIC language mode.

## Running Your First and Second Program

Read through the next three sections that include:

1. Loading a BASIC program Tape
2. Breakout Game Tape
3. Color Demo Tape

Then load and run each program tape. Additional information on Apple II's Integer BASIC is in the next section of this manual.

## Running 16K Startrek

If you have 16K Bytes or larger memory in your Apple, you will also receive a "STARTREK" game tape. Load this program just as you did the previous two, but before you "RUN" it, type in "HIMEM: 16384" to set exactly where in memory this program is to run.

## LOADING A PROGRAM TAPE

### INTRODUCTION

This section describes a procedure for loading BASIC programs successfully into the Apple II. The process of loading a program is divided into three sections; System Checkout, Loading a Tape and What to do when you have Loading Problems. They are discussed below.

When loading a tape, the Apple II needs a signal of about 2 1/2 to 5 volts peak-to-peak. Commonly, this signal is obtained from the "Monitor" or "earphone" output jack on the tape recorder. Inside most tape recorders, this signal is derived from the tape recorder's speaker. One can take advantage of this fact when setting the volume levels. Using an Apple Computer pre-recorded tape, and with all cables disconnected, play the tape and adjust the volume to a loud but un-distorted level. You will find that this volume setting will be quite close to the optimum setting.

Some tape recorders (mostly those intended for use with hi-fi sets) do not have an "earphone" or high-level "monitor" output. These machines have outputs labeled "line output" for connection to the power amplifier. The signal levels at these outputs are too low for the Apple II in most cases.

Cassette tape recorders in the \$40 - \$50 range generally have ALC (Automatic Level Control) for recording from the microphone input. This feature is useful since the user doesn't have to set any volume controls to obtain a good recording. If you are using a recorder which must be adjusted, it will have a level meter or a little light to warn of excessive recording levels. Set the recording level to just below the level meter's maximum, or to just a dim indication on the level lamp. Listen to the recorded tape after you've saved a program to ensure that the recording is "loud and clear".

Apple Computer has found that an occasional tape recorder will not function properly when both Input and Output cables are plugged in at the same time. This problem has been traced to a ground loop in the tape recorder itself which prevents making a good recording when saving a program. The easiest solution is to unplug the "monitor" output when recording. This ground loop does not influence the system when loading a pre-recorded tape.

Tape recorder head alignment is the most common source of tape recorder problems. If the playback head is skewed, then high frequency information on pre-recorded tapes is lost and all sorts of errors will result. To confirm that head alignment is the problem, write a short program in BASIC. >10 END is sufficient. Then save this program. And then rewind and load the program. If you can accomplish this easily but cannot load pre-recorded tapes, then head alignment problems are indicated.

Apple Computer pre-recorded tapes are made on the highest quality professional duplicating machines, and these tapes may be used by the service technician to align the tape recorder's heads. The frequency response of the tape recorder should be fairly good; the 6 KHz tone should be not more than 3 db down from a 1 KHz tone, and a 9 KHz tone should be no more than 9 db down. Note that recordings you have made yourself with mis-aligned heads may not play properly with the heads properly aligned. If you made a recording with a skewed record head, then the tiny magnetic fields on the tape will be skewed as well, thus playing back properly only when the skew on the tape exactly matches the skew of the tape recorder's heads. If you have saved valuable programs with a skewed tape recorder, then borrow another tape recorder, load the programs with the old tape recorder into the Apple, then save them on the borrowed machine. Then have your tape recorder properly aligned.

Listening to the tape can help solve other problems as well. Flaws in the tape, excessive speed variations, and distortion can be detected this way. Saving a program several times in a row is good insurance against tape flaws. One thing to listen for is a good clean tone lasting for at least 3 1/2 seconds is needed by the computer to "set up" for proper loading. The Apple puts out this tone for about 10 seconds when saving a program, so you normally have 6 1/2 seconds of leeway. If the playback volume is too high, you may pick up tape noise before getting to the set-up tone. Try a lower playback volume.

#### SYSTEM CHECKOUT

A quick check of the Apple II computer system will help you spot any problems that might be due to improperly placed or missing connections between the Apple II, the cassette interface, the Video display, and the game paddles. This checkout procedure takes just a few seconds to perform and is a good way of insuring that everything is properly connected before the power is turned on.



1. POWER TO APPLE - check that the AC power cord is plugged into an appropriate wall socket, which includes a "true" ground and is connected to the Apple II.
2. CASSETTE INTERFACE - check that at least one cassette cable double ended with miniature phone tip jacks is connected between the Apple II cassette Input port and the tape recorder's MONITOR plug socket.
3. VIDEO DISPLAY INTERFACE -
  - a) for a video monitor - check that a cable connects the monitor to the Apple's video output port.
  - b) for a standard television - check that an adapter (RF modulator) is plugged into the Apple II (either in the video output (K 14) or the video auxillary socket (J148), and that a cable runs between the television and the Adapter's output socket.
4. GAME PADDLE INTERFACE - if paddles are to be used, check that they are connected into the Game I/O connector (J14) on the right-hand side of the Apple II mainboard.
5. POWER ON - flip on the power switch in back of the Apple II, the "power" indicator on the keyboard will light. Also make sure the video monitor (or TV set) is turned on.

After the Apple II system has been powered up and the video display presents a random matrix of question marks or other text characters the following procedure can be followed to load a BASIC program tape:

1. Hit the RESET key.  
An asterick, "\*", should appear on the lefthand side of the screen below the random text pattern. A flashing white cursor will appear to the right of the asterick.
2. Hold down the CTRL key, depress and release the B key, then depress the "RETURN" key and release the "CTRL" key. A right facing arrow should appear on the lefthand side of the screen with a flashing cursor next to it. If it doesn't, repeat steps 1 and 2.
3. Type in the word "LOAD" on the keyboard. You should see the word in between the right facing arrow and the flashing cursor. Do not depress the "RETURN" key yet.
4. Insert the program cassette into the tape recorder and rewind it.
5. If not already set, adjust the Volume control to 50-70% maximum. If present, adjust the Tone control to 80-100% maximum.

6. Start the tape recorder in "PLAY" mode and now depress the "RETURN" key on the Apple II.
7. The cursor will disappear and Apple II will beep in a few seconds when it finds the beginning of the program. If an error message is flashed on the screen, proceed through the steps listed in the Tape Problem section of this paper.
8. A second beep will sound and the flashing cursor will reappear after the program has been successfully loaded into the computer.
9. Stop the tape recorder. You may want to rewind the program tape at this time.
10. Type in the word "RUN" and depress the "RETURN" key.

The steps in loading a program have been completed and if everything has gone satisfactorily the program will be operating now.

#### LOADING PROBLEMS

Occasionally, while attempting to load a BASIC program Apple II beeps and a memory full error is written on the screen. At this time you might wonder what is wrong with the computer, with the program tape, or with the cassette recorder. Stop. This is the time when you need to take a moment and checkout the system rather than haphazardly attempting to resolve the loading problem. Thoughtful action taken here will speed in a program's entry. If you were able to successfully turn on the computer, reset it, and place it into BASIC then the Apple II is probably operating correctly. Before describing a procedure for resolving this loading problem, a discussion of what a memory full error is in order.

The memory full error displayed upon loading a program indicates that not enough (RAM) memory workspace is available to contain the incoming data. How does the computer know this? Information contained in the beginning of the program tape declares the record length of the program. The computer reads this data first and checks it with the amount of free memory. If adequate workspace is available program loading continues. If not, the computer beeps to indicate a problem, displays a memory full error statement, stops the loading procedure, and returns command of the system to the keyboard. Several reasons emerge as the cause of this problem.

## Memory Size too Small

Attempting to load a 16K program into a 4K Apple II will generate this kind of error message. It is called loading too large of a program. The solution is straight forward: only load appropriately sized programs into suitably sized systems.

Another possible reason for an error message is that the memory pointers which indicate the bounds of available memory have been preset to a smaller capacity. This could have happened through previous usage of the "HIMEN:" and "LOMEN:" statements. The solution is to reset the pointers by B<sup>C</sup> (CTRL B) command. Hold the CTRL key down, depress and release the B key, then depress the RETURN key and release the CTRL key. This will reset the system to maximum capacity.

## Cassette Recorder Inadjustment

If the Volume and Tone controls on the cassette recorder are not properly set a memory full error can occur. The solution is to adjust the Volume to 50-70% maximum and the Tone (if it exists) to 80-100% maximum.\*

A second common recorder problem is skewed head azimuth. When the tape head is not exactly perpendicular to the edges of the magnetic tape some of the high frequency data on tape can be skipped. This causes missing bits in the data sent to the computer. Since the first data read is record length an error here could cause a memory full error to be generated because the length of the record is inaccurate. The solution: adjust tape head azimuth. It is recommended that a competent technician at a local stereo shop perform this operation. Often times new cassette recorders will not need this adjustment.

\*Apple Computer Inc. has tested many types of cassette recorders and so far the Panasonic RQ-309 DS (less than \$40.00) has an excellent track record for program loading.

## Tape Problems

A memory full error can result from unintentional noise existing in a program tape. This can be the result of a program tape starting on its header which sometimes causes a glitch going from a nonmagnetic to magnetic recording surface and is interpreted by the computer as the record length. Or, the program tape can be defective due to false erasure, imperfections in the tape, or physical damage. The solution is to take a moment and listen to the tape. If any imperfections are heard then replacement of the tape is called for. Listening to the tape assures that you know what a "good" program tape sounds like. If you have any questions about this please contact your local dealer or Apple for assistance.

If noise or a glitch is heard at the beginning of a tape advance the tape to the start of the program and re-Load the tape.

### Dealing with the Loading Problem

With the understanding of what a memory full error is an efficient way of dealing with program tape loading problems is to perform the following procedure:

1. Check the program tape for its memory requirements. Be sure that you have a large enough system.
2. Before loading a program reset the memory pointers with the  $B_c$  (control B) command.
3. In special cases have the tape head azimuth checked and adjusted.
4. Check the program tape by listening to it.
  - a) Replace it if it is defective, or
  - b) start it at the beginning of the program.
5. Then re-LOAD the program tape into the Apple II.

In most cases if the preceding is followed a good tape load will result.

### UNSOLVED PROBLEMS

If you are having any unsolved loading problems, contact your nearest local dealer or Apple Computer Inc.

## BREAKOUT GAME TAPE

### PROGRAM DESCRIPTION

Breakout is a color graphics game for the Apple II computer. The object of the game is to "knock-out" all 160 colored bricks from the playing field by hitting them with the bouncing ball. You direct the ball by hitting it with a paddle on the left side of the screen. You control the paddle with one of the Apple's Game Paddle controllers. But watch out: you can only miss the ball five times!

There are eight columns of bricks. As you penetrate through the wall the point value of the bricks increases. A perfect game is 720 points; after five balls have been played the computer will display your score and a rating such as "Very Good". "Terrible!", etc. After ten hits of the ball, its speed will double, making the game more difficult. If you break through to the back wall, the ball will rebound back and forth, racking up points.

Breakout is a challenging game that tests your concentration, dexterity, and skill.

### REQUIREMENTS

This program will fit into a 4K or greater system.  
BASIC is the programming language used.

### PLAYING BREAKOUT

1. Load Breakout game following instructions in the "Loading a BASIC Program from Tape" section of this manual.
2. Enter your name and depress RETURN key.
3. If you want standard BREAKOUT colors type in Y or Yes and hit RETURN. The game will then begin.
4. If the answer to the previous questions was N or No then the available colors will be displayed. The player will be asked to choose colors, represented by a number from 0 to 15, for background, even bricks, odd bricks, paddle and ball colors. After these have been chosen the game will begin.

5. At the end of the game you will be asked if they want to play again. A Y or Yes response will start another game. A N or No will exit from the program.

NOTE: A game paddle (150k ohm potentiometer) must be connected to PDL (Ø) of the Game I/O connector for this game.

## COLOR DEMO TAPE

### PROGRAM DESCRIPTION

COLOR DEMO demonstrates some of the Apple II video graphics capabilities. In it are ten examples: Lines, Cross, Weaving, Tunnel, Circle, Spiral, Tones, Spring, Hyperbola, and Color Bars. These examples produce various combinations of visual patterns in fifteen colors on a monitor or television screen. For example, Spiral combines colorgraphics with tones to produce some amusing patterns. Tones illustrates various sounds that you can produce with the two inch Apple speaker. These examples also demonstrate how the paddle inputs (PDL(X)) can be used to control the audio and visual displays. Ideas from this program can be incorporated into other programs with a little modification.

### REQUIREMENTS

4K or greater Apple II system, color monitor or television, and paddles are needed to use this program. BASIC is the programming language used.

BREAKOUT GAME  
PROGRAM LISTING

PROGRAM LISTING

```

5 GOTO 15
10 Q=( PDL (0)-20)/6: IF Q<0 THEN
  Q=0: IF Q>=34 THEN Q=34: COLOR=
  D: VLIN Q,Q+5 AT 0: COLOR=A:
  IF P>Q THEN 175: IF Q THEN
  VLIN 0,Q-1 AT 0:P=Q: RETURN

15 DIM A$(15),B$(10):A=1:B=13:
  C=9:D=6:E=15: TEXT : CALL -
  936: VTAB 4: TAB 10: PRINT
  "*** BREAKOUT ***": PRINT
20 PRINT "  OBJECT IS TO DESTROY
  ALL BRICKS": PRINT : INPUT
  "HI, WHAT'S YOUR NAME? ",A$

25 PRINT "STANDARD COLORS ";A$
  ;: INPUT " Y/N? ",B$: GR : CALL
  -936: IF B$(1,1)="#N" THEN 40
  : FOR I=0 TO 39: COLOR=I/2*
  (1<32): VLIN 0,39 AT I
30 NEXT I: POKE 34,20: PRINT :
  PRINT : PRINT : FOR I=0 TO
  15: VTAB 21+I MOD 2: TAB I+
  I+1: PRINT I: NEXT I: POKE
  34,22: VTAB 24: PRINT : PRINT
  "BACKGROUND":
35 GOSUB 95:A=E: PRINT "EVEN BRICK"
  ;: GOSUB 95:B=E: PRINT "ODD BRIC
  K": GOSUB 95:C=E: PRINT "PADDLE
  ";: GOSUB 95:D=E: PRINT "BALL"
  ;: GOSUB 95
40 POKE 34,20: COLOR=A: FOR I=
  0 TO 39: VLIN 0,39 AT I: NEXT
  I: FOR I=20 TO 34 STEP 2: TAB
  I+1: PRINT I/2-9:; COLOR=B:
  VLIN 0,39 AT I: COLOR=C: FOR
  J=I MOD 4 TO 39 STEP 4
45 VLIN J,J+1 AT I: NEXT J,I: TAB
  5: PRINT "SCORE = 0": PRINT
  : PRINT : POKE 34,21:S=0:P=
  5:L=5:X=19:Y=19:L=6
50 COLOR=A: PLOT X,Y/3:X=19:Y=
  RND (120):V=-1:W= RND (5)-
  2:L=L-1: IF L<1 THEN 120: TAB
  6: IF L>1 THEN PRINT L;" BALLS L
  EFT"
55 IF L=1 THEN PRINT "LAST BALL, "
  ;A$: PRINT : FOR I=1 TO 100
  : GOSUB 10: NEXT I:M=1:N=0
60 J=Y+W: IF J>0 AND J<120 THEN
  65:W=-W:J=Y: FOR I=1 TO 6:K=
  PEEK (-16336): NEXT I
65 I=X+V: IF I<0 THEN 100: GOSUB
  170: COLOR=A:K=J/3: IF I>39
  THEN 75: IF SCRNI,K)=A THEN
  85: IF I THEN 100:N=N+1:V=(
  N>5)+1:W=(K-P)*2-5:M=1
70 Z= PEEK (-16336)- PEEK (-16336
  )+ PEEK (-16336)- PEEK (-16336
  )+ PEEK (-16336)- PEEK (-16336
  )+ PEEK (-16336): GOTO 85
75 FOR I=1 TO 6:M= PEEK (-16336
  ): NEXT I:I=X:M=0
80 V=-V
85 PLOT X,Y/3: COLOR=E: PLOT I,
  K:X=I:Y=J: GOTO 60
90 PRINT "INVALID. REENTER":
95 INPUT " COLOR (0 TO 15)",E:
  IF E<0 OR E>15 THEN 90: RETURN
100 IF M THEN V= ABS (V): VLIN
  K/2*2,K/2*2+1 AT I:S=5+I/2-
  9: VTAB 21: TAB 10: PRINT 5
105 Q= PEEK (-16336)- PEEK (-16336
  )+ PEEK (-16336)- PEEK (-16336
  )+ PEEK (-16336)- PEEK (-16336
  )+ PEEK (-16336)- PEEK (-16336
  )+ PEEK (-16336)- PEEK (-16336
  )
110 IF S<720 THEN 80
115 PRINT "CONGRATULATIONS, ";A$
  ;" YOU WIN!": GOTO 165
120 PRINT "YOUR SCORE OF ";S;" IS "
  ;: GOTO 125+(S/100)*5
125 PRINT "TERRIBLE!": GOTO 165
130 PRINT "LOUSY.": GOTO 165
135 PRINT "POOR.": GOTO 165
140 PRINT "FAIR.": GOTO 165
145 PRINT "GOOD.": GOTO 165
150 PRINT "VERY GOOD.": GOTO 165
155 PRINT "EXCELLENT.": GOTO 165
160 PRINT "NEARLY PERFECT."
165 PRINT "ANOTHER GAME ";A$;" (Y/N)
  ";: INPUT A$: IF A$(1,1)="Y"
  THEN 25: TEXT : CALL -936:
  VTAB 10: TAB 10: PRINT "GAME OV
  ER": END
170 Q=( PDL (0)-20)/6: IF Q<0 THEN
  Q=0: IF Q>=34 THEN Q=34: COLOR=
  D: VLIN Q,Q+5 AT 0: COLOR=A:
  IF P>Q THEN 175: IF Q THEN
  VLIN 0,Q-1 AT 0:P=Q: RETURN
175 IF P=Q THEN RETURN : IF Q#34
  THEN VLIN Q+6,39 AT 0:P=Q:
  RETURN
180 FOR I=1 TO 80:Q= PEEK (-16336
  ): NEXT I: GOTO 50

```

COLOR DEMO PROGRAM  
LISTING

PROGRAM LISTING

```

10 DIM C(4): POKE 2,173: POKE
   3,49: POKE 4,192: POKE 5,165
   : POKE 6,0: POKE 7,32: POKE
   8,168: POKE 9,252: POKE 10,
   165: POKE 11,1: POKE 12,288

20 POKE 13,4: POKE 14,198: POKE
   15,24: POKE 16,248: POKE 17
   ,5: POKE 18,198: POKE 19,1:
   POKE 20,76: POKE 21,2: POKE
   22,0: POKE 23,96

30 TEXT : CALL -936: VTAB 4: TAB
   8: PRINT "4K COLOR DEMOS": PRINT
   : PRINT "1 LINES": PRINT "2 CROS
   5": PRINT "3 WEAVING"

40 PRINT "4 TUNNEL": PRINT "5 CIRCL
   E": PRINT "6 SPIRAL **": PRINT
   "7 TONES ** ": PRINT "8 SPRING"

50 PRINT "9 HYPERBOLA": PRINT
   "10 COLOR BARS": PRINT : PRINT
   "** NEEDS PDL(0) CONNECTED"
   : PRINT

60 PRINT "HIT ANY KEY FOR NEW DEMO"
   :Z=0: PRINT : INPUT "WHICH DEMO
   # ",I: GR : IF I>0 AND I<11
   THEN GOTO 100*I: GOTO 30

70 INPUT "WHICH DEMO WOULD YOU LIKE
   ",I: GR : IF I AND I<20 THEN
   GOTO 100*I: GOTO 30

100 I=I+I MOD 79:J=I+(I>39)*(79
   -I-I): GOSUB 2000: GOSUB 10000
   : GOTO 100

200 I=I+I MOD 39:J=I: GOSUB 2000
   :J=39-I: GOSUB 2000: GOSUB
   10000: GOTO 200

300 J=J+I:J=J MOD 22+I: FOR I=1
   TO 1295: COLOR=I MOD J+7: PLOT
   (2*I) MOD 37,(3*I) MOD 35: NEXT
   I: GOSUB 10000: GOTO 300

400 FOR I=1 TO 4:C(I)= RND (16)
   : NEXT I

410 FOR I=3 TO 1 STEP -1:C(I+1)
   =C(I): NEXT I:C(1)= RND (16
   ): FOR I=1 TO 5: FOR J=1 TO
   4

420 COLOR=C(J):L=J*5+14+I:K=39-
   L: HLIN K,L AT K: VLIN K,L AT
   L: HLIN K,L AT L: VLIN K,L AT
   K: NEXT J,I: GOSUB 10000: GOTO
   410

500 Z=20: GOTO 900

600 COLOR= RND (16): FOR I=0 TO
   18 STEP 2:J=39-I: HLIN I,J AT
   I: GOSUB 640: VLIN I,J AT J:
   GOSUB 640

610 HLIN I+2,J AT J: GOSUB 640:
   VLIN I+2,J AT I+2: GOSUB 640
   : NEXT I

620 COLOR= RND (16): FOR I=18 TO
   0 STEP -2:J=39-I: VLIN I+2,
   J AT I+2: GOSUB 640: HLIN I+
   2,J AT J: GOSUB 640

630 VLIN I,J AT J: GOSUB 640: HLIN
   I,J AT I: GOSUB 640: NEXT I:
   GOSUB 10000: GOTO 600

640 K=I+7:L=K*K*5+K*26+70:L=32767
   /L*( PDL (0)/10): POKE 0,K:
   POKE I,L MOD 256: POKE 24,
   L/256+1: CALL 2: RETURN

700 I= RND (30)+3:J=I*I*5+I*26+
   70:K=32767/J*( PDL (0)/10):
   POKE 0,I: POKE 1,K MOD 256
   : POKE 24,(K/255)+1: CALL 2
   : GOSUB 10000: GOTO 700

800 X=3:A=1000:P=A:L=20:W=4:Y=0
   :J=1: COLOR=6: HLIN 0,39 AT
   4: COLOR=9: GOSUB 880: COLOR=
   12: VLIN 5,M-2 AT X

810 N=2*A-P-A/W: COLOR=0: GOSUB
   880: VLIN 5,39 AT X:X=X+1: IF
   X<39 THEN 820:X=3: VLIN 5,39
   AT 1: VLIN 5,39 AT 2

820 P=A:A=N:Y=A/100: COLOR=12: GOSUB
   880: COLOR=9: VLIN 5,M-2 AT
   X: COLOR=15: PLOT X-2,M: FOR
   I=0 TO J: NEXT I: GOSUB 10000
   : GOTO 810

880 M=L-Y:L1=M-1:L2=M+1: VLIN L1,
   L2 AT X-1: VLIN L1,L2 AT X:
   VLIN L1,L2 AT X+1: RETURN

900 I=I+I MOD 15: FOR Y=0 TO 39
   : FOR X=0 TO 39: COLOR=I+( ABS
   (20-X)-Z)*( ABS (20-Y)-Z)/25
   : PLOT X,Y: NEXT X,Y: GOSUB
   10000: GOTO 900

1000 CALL -936

1010 J=1+J MOD 32: COLOR=J/2: VLIN
   0,39 AT 3+J: VTAB 21+(J/2) MOD
   2: TAB 3+J: IF J MOD 2 THEN
   PRINT J/2: GOSUB 10000: GOTO
   1010

2000 COLOR= RND (16): HLIN 0,39 AT
   J: COLOR= RND (16): VLIN 0,
   39 AT J: RETURN

10000 IF PEEK (-16384)<128 THEN RETURN
   : POKE -16368,0: POP : GOTO
   30

```



THIS IS A SHORT DESCRIPTION OF HOW TO PLAY STARTREK ON THE APPLE COMPUTER.

THE UNIVERSE IS MADE UP OF 64 QUADRANTS IN AN 8 BY 8 MATRIX. THE QUADRANT IN WHICH YOU "THE ENTERPRISE" ARE, IS IN WHITE, AND A BLOW UP OF THAT QUADRANT IS FOUND IN THE LOWER LEFT CORNER. YOUR SPACE SHIP STATUS IS FOUND IN A TABLE TO THE RIGHT SIDE OF THE QUADRANT BLOW UP.

THIS IS A SEARCH AND DESTROY MISSION. THE OBJECT IS TO LONG-RANGE SENSE FOR INFORMATION AS TO WHERE KLINGONS (K) ARE, MOVE TO THAT QUADRANT, AND DESTROY.

NUMBERS DISPLAYED FOR EACH QUADRANT DENOTE:

- \* OF STARS IN THE ONES PLACE
- \* OF BASES IN THE TENS PLACE
- \* OF KLINGONS IN THE HUNDREDS PLACE

AT ANY TIME DURING THE GAME, FOR INSTANCE BEFORE ONE TOTALLY RUNS OUT OF ENERGY, OR NEEDS TO REGENERATE ALL SYSTEMS, ONE MOVES TO A QUADRANT WHICH INCLUDES A BASE, IONS NEXT TO THAT BASE (B) AT WHICH TIME THE BASE SELF-DESTRUCTS AND THE ENTERPRISE (E) HAS ALL SYSTEMS "GO" AGAIN.

TO PLAY:

1. THE COMMANDS CAN BE OBTAINED BY TYPING A "0" (ZERO) AND RETURN. THEY ARE:

- |                           |                   |
|---------------------------|-------------------|
| 1. PROPULSION             | 2. REGENERATE     |
| 3. LONG RANGE SENSORS     | 4. PHASERS        |
| 5. PHOTON TORPEDOES       | 6. GALAXY RECORD  |
| 7. COMPUTER               | 8. PROBE          |
| 9. SHIELD ENERGY          | 10. DAMAGE REPORT |
| 11. LOAD PHOTON TORPEDOES |                   |

2. THE COMMANDS ARE INVOKED BY TYPING THE NUMBER REFERING TO THEM FOLLOWED BY A "RETURN".

- A. IF RESPONSE IS 1 THE COMPUTER WILL ASK WARP OR ION AND EXPECTS "W" IF ONE WANTS TO TRAVEL IN THE GALAXY BETWEEN QUADRANTS AND AN "I" IF ONE WANTS ONLY INTERNAL QUADRANT TRAVEL. DURATION OR WARP FACTOR IS THE NUMBER OF SPACES OR QUADRANTS THE ENTERPRISE WILL MOVE. COURSE IS COMPASS READING IN DEGREES FOR THE DESIRED DESTINATION.
  - B. A 2 REGENERATES THE ENERGY AT THE EXPENSE OF TIME.
  - C. A 3 GIVES THE CONTENTS OF THE IMMEDIATE ADJACENT QUADRANTS. THE GALAXY IS WRAP-AROUND IN ALL DIRECTIONS.
  - D. A 4 FIRES PHASERS AT THE EXPENSE OF AVAILABLE ENERGY.
- E. 5 INITIATES A SET OF QUESTIONS FOR TORPEDO FIRING. THEY CAN BE FIRED AUTOMATICALLY IF THEY HAVE BEEN LOCKED ON TARGET WHILE IN THE COMPUTER MODE, OR MAY BE FIRED MANUALLY IF THE TRAJECTORY ANGLE IS KNOWN.
- F. 6, 8 AND 10 ALL GIVE INFORMATION ABOUT THE STATUS OF THE SHIP AND ITS ENVIRONMENT.
- G. 9 SETS THE SHIELD ENERGY/AVAILABLE ENERGY RATIO.
- H. 11 ASKS FOR INFORMATION ON LOADING AND UNLOADING OF PHOTON TORPEDOES AT THE ESPENSE OF AVAILABLE ENERGY. THE ANSWER SHOULD BE A SIGNED NUMBER. FOR EXAMPLE +5 OR -2.

I. 7 ENTERS A COMPUTER WHICH WILL RESPOND TO THE FOLLOWING INSTRUCTIONS:

- |                          |                          |
|--------------------------|--------------------------|
| 1. COMPUTE COURSE        | 2. LOCK PHASERS          |
| 3. LOCK PHOTON TORPEDOES |                          |
| 4. LOCK COURSE           | 5. COMPUTE TREJECTORY    |
| 6. STATUS                | 7. RETURN TO COMAND MODE |

IN THE FIRST FIVE ONE WILL HAVE TO GIVE COORDINATES. COORDINATES ARE GIVEN IN MATTHMATICAL NOTATION WITH THE EXCEPTION THAT THE "Y" VALUE IS GIVEN FIRST. AN EXAMPLE WOULD BE "Y,X"

COURSE OR TRAJECTORY:

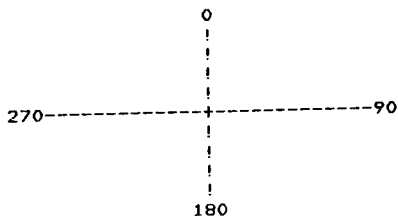

----- THIS EXPLANATION WAS WRITTEN BY ELWOOD -----  
 NOT RESPONSIBLE FOR  
 ERRORS

## LOADING THE HI-RES DEMO TAPE

### PROCEDURE

1. Power up system - turn the AC power switch in the back of the Apple II on. You should see a random matrix of question marks and other text characters. If you don't, consult the operator's manual for system checkout procedures.
2. Hit the RESET key. On the left hand side of the screen you should see an asterisk and a flashing cursor next to it below the text matrix.
3. Insert the HI-RES demo tape into the cassette and rewind it. Check Volume (50-70%) and Tone (80-100%) settings.
4. Type in "C00.FFFR" on the Apple II keyboard. This is the address range of the high resolution machine language subprogram. It extends from \$C00 to \$FFF. The R tells the computer to read in the data. Do not depress the "RETURN" key yet.
5. Start the tape recorder in playback mode and depress the "RETURN" key. The flashing cursor disappears.
6. A beep will sound after the program has been read in. STOP the tape recorder. Do not rewind the program tape yet.
7. Hold down the "CTRL" key, depress and release the B key, then depress the "RETURN" key and release the "CTRL" key. You should see a right facing arrow and a flashing cursor. The BC command places the Apple into BASIC initializing the memory pointers.
8. Type in "LOAD", restart the tape recorder in playback mode and hit the "RETURN" key. The flashing cursor disappears. This begins the loading of the BASIC subprogram of the HI-RES demo tape.
9. A beep will sound to indicate the program is being loaded.

10. A second beep will sound, and the right facing arrow will reappear with the flashing cursor. STOP the tape recorder. Rewind the tape.
11. Type in "HIMEM:8192" and hit the "RETURN" key. This sets up memory for high resolution graphics.
12. Type in "RUN" and hit the "RETURN" key. The screen should clear and momentarily a HI-RES demo menu table should appear. The loading sequence is now completed.

#### SUMMARY OF HI-RES DEMO TAPE LOADING

1. RESET
2. Type in C00.FFFR
3. Start tape recorder, hit RETURN
4. Asterick or flashing cursor reappear  
B<sup>C</sup> (CTRL B) into BASIC
5. Type in "LOAD", hit RETURN
6. BASIC prompt (7) and flashing cursor reappear. Type in "HIMEN:8192", hit RETURN
7. Type in "RUN", hit RETURN
8. STOP tape recorder, rewind tape.

# APPLE II INTEGER BASIC

1. BASIC Commands
2. BASIC Operators
3. BASIC Functions
4. BASIC Statements
5. Special Control and Editing
6. Table A — Graphics Colors
7. Special Controls and Features
8. BASIC Error Messages
9. Simplified Memory Map
10. Data Read/Save Subroutines
11. Simple Tone Subroutines
12. High Resolution Graphics
13. Additional BASIC Program Examples

## BASIC COMMANDS

Commands are executed immediately; they do not require line numbers. Most Statements (see Basic Statements Section) may also be used as commands. Remember to press Return key after each command so that Apple knows that you have finished that line. Multiple commands (as opposed to statements) on same line separated by a " : " are NOT allowed.

### COMMAND NAME

<u>AUTO</u> <i>num</i>	Sets automatic line numbering mode. Starts at line number <i>num</i> and increments line numbers by 10. To exit AUTO mode, type a control X*, then type the letters "MAN" and press the return key.
<u>AUTO</u> <i>num1, num2</i>	Same as above except increments line numbers by number <i>num2</i> .
<u>CLR</u>	Clears current BASIC variables; undimensions arrays. Program is unchanged.
<u>CON</u>	Continues program execution after a stop from a control C*. Does not change variables.
<u>DEL</u> <i>num1</i>	Deletes line number <i>num1</i> .
<u>DEL</u> <i>num1, num2</i>	Deletes program from line number <i>num1</i> through line number <i>num2</i> .
<u>DSP</u> <i>var</i>	Sets debug mode that will display variable <i>var</i> every-time that it is changed along with the line number that caused the change. (NOTE: RUN command clears DSP mode so that DSP command is effective only if program is continued by a CON or GOTO command.)
<u>HIMEM:</u> <i>expr</i>	Sets highest memory location for use by BASIC at location specified by expression <i>expr</i> in <u>decimal</u> . HIMEM: may not be increased without <u>destroying</u> program. HIMEM: is automatically set at maximum RAM memory when BASIC is entered by a control B*.
<u>GOTO</u> <i>expr</i>	Causes immediate jump to line number specified by expression <i>expr</i> .
<u>GR</u>	Sets mixed color graphics display mode. Clears screen to black. Resets scrolling window. Displays 40x40 squares in 15 colors on top of screen and 4 lines of text at bottom.
<u>LIST</u>	Lists entire program on screen.
<u>LIST</u> <i>num1</i>	Lists program line number <i>num1</i> .
<u>LIST</u> <i>num1, num2</i>	Lists program line number <i>num1</i> through line number <i>num2</i> .

LOAD *expr.*

Reads (Loads) a BASIC program from cassette tape. Start tape recorder before hitting return key. Two beeps and a ">" indicate a good load. "ERR" or "MEM" FULL ERR" message indicates a bad tape or poor recorder performance.

LOMEM: *expr*

Similar to HIMEM: except sets lowest memory location available to BASIC. Automatically set at 2048 when BASIC is entered with a control B\*. Moving LOMEM: destroys current variable values.

MAN

Clears AUTO line numbering mode to all manual line numbering after a control C\* or control X\*.

NEW

Clears (Scratches) current BASIC program.

NO DSP *var*

Clears DSP mode for variable *var*.

NO TRACE

Clears TRACE mode.

RUN

Clears variables to zero, undimensions all arrays and executes program starting at lowest statement line number.

RUN *expr*

Clears variables and executes program starting at line number specified by expression *expr*.

SAVE

Stores (saves) a BASIC program on a cassette tape. Start tape recorder in record mode prior to hitting return key.

TEXT

Sets all text mode. Screen is formatted to display alpha-numeric characters on 24 lines of 40 characters each. TEXT resets scrolling window to maximum.

TRACE

Sets debug mode that displays line number of each statement as it is executed.

- \* Control characters such as control X or control C are typed by holding down the CTRL key while typing the specified letter. This is similar to how one holds down the shift key to type capital letters. Control characters are NOT displayed on the screen but are accepted by the computer. For example, type several control G's. We will also use a superscript C to indicate a control character as in X<sup>C</sup>.

## BASIC Operators

<u>Symbol</u>	<u>Sample Statement</u>	<u>Explanation</u>
<u>Prefix Operators</u>		
( )	10 X= 4*(5 + X)	Expressions within parenthesis ( ) are always evaluated first.
+	20 X= 1+4*5	Optional; +1 times following expression.
-	30 ALPHA = -(BETA +2)	Negation of following expression.
NOT	40 IF A NOT B THEN 200	Logical Negation of following expression; 0 if expression is true (non-zero), 1 if expression is false (zero).
<u>Arithmetic Operators</u>		
↑	60 Y = X↑3	Exponentiate as in X <sup>3</sup> . NOTE: ↑ is shifted letter N.
*	70 LET DOTS=A*B*N2	Multiplication. NOTE: Implied multiplication such as (2 + 3)(4) is not allowed thus N2 in example is a variable not N * 2.
/	80 PRINT GAMMA/S	Divide
MOD	90 X = 12 MOD 7 100 X = X MOD(Y+2)	Modulo: Remainder after division of first expression by second expression.
+	110 P = L + G	Add
-	120 XY4 = H-D	Subtract
=	130 HEIGHT=15 140 LET SIZE=7*5 150 A(8) = 2 155 ALPHA\$ = "PLEASE"	Assignment operator; assigns a value to a variable. LET is optional

## Relational and Logical Operators

The numeric values used in logical evaluation are "true" if non-zero, "false" if zero.

<u>Symbol</u>	<u>Sample Statement</u>	<u>Explanation</u>
=	160 IF D = E THEN 500	Expression "equals" expression.
=	170 IF A\$(1,1)= "Y" THEN 500	String variable "equals" string variable.
# or < >	180 IF ALPHA #X*Y THEN 500	Expression "does not equal" expression.
#	190 IF A\$ # "NO" THEN 500	String variable "does not equal" string variable. NOTE: If strings are not the same length, they are considered un-equal. < > not allowed with strings.
>	200 IF A>B THEN GO TO 50	Expression "is greater than" expression.
<	210 IF A+1<B-5 THEN 100	Expression "is less than" expression.
>=	220 IF A>=B THEN 100	Expression "is greater than or equal to" expression.
<=	230 IF A+1<=B-6 THEN 200	Expression "is less than or equal to" expression.
AND	240 IF A>B AND C<D THEN 200	Expression 1 "and" expression 2 must both be "true" for statements to be true.
OR	250 IF ALPHA OR BETA+1 THEN 200	If either expression 1 or expression 2 is "true", statement is "true".



## BASIC FUNCTIONS

Functions return a numeric result. They may be used as expressions or as part of expressions. PRINT is used for examples only, other statements may be used. Expressions following function name must be enclosed between two parenthesis signs.

### FUNCTION NAME

ABS ( <i>expr</i> )	300 PRINT ABS(X)	Gives absolute value of the expression <i>expr</i> .
ASC ( <i>str\$</i> )	310 PRINT ASC("BACK") 320 PRINT ASC(B\$) 330 PRINT ASC(B\$(4,4)) 335 PRINT ASC(B\$(Y))	Gives decimal ASCII value of designated string variable <i>str\$</i> . If more than one character is in designated string or sub-string, it gives decimal ASCII value of first character.
LEN ( <i>str\$</i> )	340 PRINT LEN(B\$)	Gives current length of designated string variable <i>str\$</i> ; i.e., number of characters.
PDL ( <i>expr</i> )	350 PRINT PDL(X)	Gives number between 0 and 255 corresponding to paddle position on game paddle number designated by expression <i>expr</i> and must be legal paddle (0,1,2, or 3) or else 255 is returned.
PEEK ( <i>expr</i> )	360 PRINT PEEK(X)	Gives the decimal value of number stored of decimal memory location specified by expression <i>expr</i> . For MEMORY locations above 32676, use negative number; i.e., HEX location FFF0 is -16
RND ( <i>expr</i> )	370 PRINT RND(X)	Gives random number between 0 and (expression <i>expr</i> -1) if expression <i>expr</i> is positive; if minus, it gives random number between 0 and (expression <i>expr</i> +1).
SCRN( <i>expr1</i> , <i>expr2</i> )	380 PRINT SCRN (X1,Y1)	Gives color (number between 0 and 15) of screen at horizontal location designated by expression <i>expr1</i> and vertical location designated by expression <i>expr2</i> Range of expression <i>expr1</i> is 0 to 39. Range of expression <i>expr2</i> is 0 to 39 if in standard mixed colorgraphics display mode as set by GR command or 0 to 47 if in all color mode set by POKE -16304 ,0: POKE - 16302,0.
SGN ( <i>expr</i> )	390 PRINT SGN(X)	Gives sign (not sine) of expression <i>expr</i> i.e., -1 if expression <i>expr</i> is negative, zero if zero and +1 if <i>expr</i> is positive.

## BASIC STATEMENTS

Each BASIC statement must have a line number between 0 and 32767. Variable names must start with an alpha character and may be any number of alpha-numeric characters up to 100. Variable names may not contain buried any of the following words: AND, AT, MOD, OR, STEP, or THEN. Variable names may not begin with the letters END, LET, or REM. String variables names must end with a \$ (dollar sign). Multiple statements may appear under the same line number if separated by a : (colon) as long as the total number of characters in the line (including spaces) is less than approximately 150 characters. Most statements may also be used as commands. BASIC statements are executed by RUN or GOTO commands.

### NAME

<u>CALL</u> <i>expr</i>	10 CALL-936	Causes execution of a machine level language subroutine at <u>decimal</u> memory location specified by expression <i>expr</i> . Locations above 32767 are specified using negative numbers; i.e., location in example 10 is hexadecimal number \$FC53
<u>COLOR=</u> <i>expr</i>	30 COLOR=12	In standard resolution color (GR) graphics mode, this command sets screen TV color to value in expression <i>expr</i> in the range 0 to 15 as described in Table A. Actually expression <i>expr</i> may be in the range 0 to 255 without error message since it is implemented as if it were expression <i>expr</i> MOD 16.
<u>DIM</u> <i>var1</i> ( <i>expr1</i> ) <i>str</i> \$ ( <i>expr2</i> ) <i>var2</i> ( <i>expr3</i> )	50 DIM A(20),B(10) 60 DIM B\$(30) 70 DIM C (2)	The DIM statement causes APPLE II to reserve memory for the specified variables. For number arrays APPLE reserves approximately 2 times <i>expr</i> bytes of memory limited by available memory. For string arrays - <i>str</i> \$ ( <i>expr</i> ) must be in the range of 1 to 255. Last defined variable may be redimensioned at any time; thus, example in line is illegal but 85 is allowed.
	Illegal: 80 DIM A(30)	
	Legal: 85 DIM C(1000)	
<u>DSP</u> <i>var</i>	Legal: 90 DSP AX: DSP L	Sets debug mode that DSP variable <i>var</i> each time it changes and the line number where the change occurred.
	Illegal: 100 DSP AX,B 102 DSP AB\$ 104 DSP A(5)	
	Legal: 105 A=A(5): DSP A	

<u>NAME</u>	<u>EXAMPLE</u>	<u>DESCRIPTION</u>
<u>END</u>	110 END	Stops program execution. Sends carriage return and "> " BASIC prompt) to screen.
<u>FOR</u> <i>var</i> = <i>expr1</i> TO <i>expr2</i> STEP <i>expr3</i>	110 FOR L=0 to 39 120 FOR X=Y1 TO Y3 130 FOR I=39 TO 1 150 GOSUB 100 *J2	Begins FOR...NEXT loop, initializes variable <i>var</i> to value of expression <i>expr1</i> then increments it by amount in expression <i>expr3</i> each time the corresponding "NEXT" statement is encountered, until value of expression <i>expr2</i> is reached. If STEP <i>expr3</i> is omitted, a STEP of +1 is assumed. Negative numbers are allowed.
<u>GOSUB</u> <i>expr</i>	140 GOSUB 500	Causes branch to BASIC subroutine starting at legal line number specified by expression <i>expr</i> . Subroutines may be nested up to 16 levels.
<u>GOTO</u> <i>expr</i>	160 GOTO 200 170 GOTO ALPHA+100	Causes immediate jump to legal line number specified by expression <i>expr</i> .
<u>GR</u>	180 GR 190 GR: POKE -16302,0	Sets mixed standard resolution color graphics mode. Initializes COLOR = 0 (Black) for top 40x40 of screen and sets scrolling window to lines 21 through 24 by 40 characters for four lines of text at bottom of screen. Example 190 sets all color mode (40x48 field) with no text at bottom of screen.
<u>HLIN</u> <i>expr1</i> , <i>expr2</i> AT <i>expr3</i>	200 HLIN 0,39 AT 20 210 HLIN Z,Z+6 AT I	In standard resolution color graphics mode, this command draws a horizontal line of a predefined color (set by COLOR=) starting at horizontal position defined by expression <i>expr1</i> and ending at position <i>expr2</i> at vertical position defined by expression <i>expr3</i> . <i>expr1</i> and <i>expr2</i> must be in the range of 0 to 39 and <i>expr1</i> < = <i>expr2</i> . <i>expr3</i> be in the range of 0 to 39 (or 0 to 47 if not in mixed mode).
Note:	HLIN 0, 19 AT 0 is a horizontal line at the top of the screen extending from left corner to center of screen and HLIN 20,39 AT 39 is a horizontal line at the bottom of the screen extending from center to right corner.	

IF expression 220 IF A > B THEN  
THEN statement PRINT A  
 230 IF X=0 THEN C=1  
 240 IF A#10 THEN  
 GOSUB 200  
 250 IF A\$(1,1)# "Y"  
 THEN 100

Illegal:

260 IF L > 5 THEN 50:  
 ELSE 60

Legal:

270 IF L > 5 THEN 50  
 GO TO 60

INPUT var1, 280 INPUT X,Y,Z(3)  
var2, str\$ 290 INPUT "AMT",  
 DLLR  
 300 INPUT "Y or N?", A\$

If *expression* is true (non-zero) then execute *statement*; if false do not execute *statement*. If *statement* is an expression, then a GOTO *expr* type of statement is assumed to be implied. The "ELSE" in example 260 is illegal but may be implemented as shown in example 270.

Enters data into memory from I/O device. If number input is expected, APPLE will output "?"; if string input is expected no "?" will be outputted. Multiple numeric inputs to same statement may be separated by a comma or a carriage return. String inputs must be separated by a carriage return only. One pair of " " may be used immediately after INPUT to output prompting text enclosed within the quotation marks to the screen.

IN# expr 310 IN# 6  
 320 IN# Y+2  
 330 IN# 0

Transfers source of data for subsequent INPUT statements to peripheral I/O slot (1-7) as specified as by expression *expr*. Slot 0 is not addressable from BASIC. IN#0 (Example 330) is used to return data source from peripheral I/O to keyboard connector.

LET 340 LET X=5

Assignment operator. "LET" is optional

LIST num1, 350 IF X > 6 THEN  
num2 LIST 50

Causes program from line number *num1* through line number *num2* to be displayed on screen.

NEXT var1, 360 NEXT I  
var2 370 NEXT J,K

Increments corresponding "FOR" variable and loops back to statement following "FOR" until variable exceeds limit.

NO DSP var 380 NO DSP I

Turns-off DSP debug mode for variable

NO TRACE 390 NO TRACE

Turns-off TRACE debug mode

<u>PLOT</u> , <i>expr1</i> , <i>expr2</i>	400 PLOT 15, 25 400 PLT XV,YV	In standard resolution color graphics, this command plots a small square of a predefined color (set by COLOR=) at horizontal location specified by expression <i>expr1</i> in range 0 to 39 and vertical location specified by expression <i>expr2</i> in range 0 to 39 (or 0 to 47 if in all graphics mode) NOTE: PLOT 0 0 is upper left and PLOT 39, 39 (or PLOT 39, 47) is lower right corner.
<u>POKE</u> <i>expr1</i> , <i>expr2</i>	420 POKE 20, 40 430 POKE 7*256, XMOD255	Stores <u>decimal</u> number defined by expression <i>expr2</i> in range of 0 255 at <u>decimal</u> memory location specified by expression <i>expr1</i> . Locations above 32767 are specified by negative numbers.
<u>POP</u>	440 POP	"POPS" nested GOSUB return stack address by one.
<u>PRINT</u> <i>var1</i> , <i>var</i> , <i>str\$</i>	450 PRINT L1 460 PRINT L1, X2 470 PRINT "AMT=";DX 480 PRINT A\$;B\$; 490 PRINT 492 PRINT "HELLO" 494 PRINT 2+3	Outputs data specified by variable <i>var</i> or string variable <i>str\$</i> starting at current cursor location. If there is not trailing "," or ";" (Ex 450) a carriage return will be generated. Commas (Ex. 460) outputs data in 5 left justified columns. Semi-colon (Ex. 470) inhibits print of any spaces. Text imbedded in " " will be printed and may appear multiple times.
<u>PR#</u> <i>expr</i>	500 PR# 7	Like IN#, transfers output to I/O slot defined by expression <i>expr</i> PR# 0 is video output not I/O slot 0.
<u>REM</u>	510 REM REMARK	No action. All characters after REM are treated as a remark until terminated by a carriage return.
<u>RETURN</u>	520 RETURN 530 IFX= 5 THEN RETURN	Causes branch to statement following last GOSUB; i.e., RETURN ends a subroutine. Do not confuse "RETURN" <u>statement</u> with Return <u>key</u> on keyboard.

<u>TAB</u> <i>expr</i>	530 TAB 24 540 TAB I+24 550 IF A#B THEN TAB 20	Moves cursor to absolute horizontal position specified by expression <i>expr</i> in the range of 1 to 40. Position is left to right
<u>TEXT</u>	550 TEXT 560 TEXT: CALL-936	Sets all text mode. Resets scrolling window to 24 lines by 40 characters. Example 560 also clears screen and homes cursor to upper left corner
<u>TRACE</u>	570 TRACE 580 IFN > 32000 THEN TRACE	Sets debug mode that displays each line number as it is executed.
<u>VLIN</u> <i>expr1, expr2</i> AT <i>expr3</i>	590 VLIN 0, 39AT15 600 VLIN Z,Z+6ATY	Similar to HLIN except draws vertical line starting at <i>expr1</i> and ending at <i>expr2</i> at horizontal position <i>expr3</i> .
<u>VTAB</u> <i>expr</i>	610 VTAB 18 620 VTAB Z+2	Similar to TAB. Moves cursor to absolute vertical position specified by expression <i>expr</i> in the range 1 to 24. VTAB 1 is top line on screen; VTAB24 is bottom.

## SPECIAL CONTROL AND EDITING CHARACTERS

"Control" characters are indicated by a super-scripted "C" such as G<sup>C</sup>. They are obtained by holding down the CTRL key while typing the specified letter. Control characters are NOT displayed on the TV screen. B<sup>C</sup> and C<sup>C</sup> must be followed by a carriage return. Screen editing characters are indicated by a sub-scripted "E" such as D<sub>E</sub>. They are obtained by pressing and releasing the ESC key then typing specified letter. Edit characters send information only to display screen and does not send data to memory. For example, U<sup>C</sup> moves to cursor to right and copies text while A<sub>E</sub> moves cursor to right but does not copy text.

### CHARACTER

### DESCRIPTION OF ACTION

RESET key	Immediately interrupts any program execution and resets computer. Also sets all text mode with scrolling window at maximum. Control is transferred to System Monitor and Apple prompts with a "*" (asterisk) and a bell. Hitting RESET key does NOT destroy existing BASIC or machine language program.
Control B	If in System Monitor (as indicated by a "*"), a control B and a carriage return will transfer control to BASIC, <u>scratching (killing) any existing BASIC program</u> and set HIMEM: to maximum installed user memory and LOMEM: to 2048.
Control C	If in BASIC, halts program and displays line number where stop occurred*. Program may be continued with a CON command. If in <u>System Monitor</u> , (as indicated by "*"), control C and a carriage return will enter BASIC <u>without</u> killing current program.
Control G	Sounds bell (beeps speaker)
Control H	Backspaces cursor and deletes any overwritten characters from computer but not from screen. Apple supplied keyboards have special key "<" on right side of keyboard that provides this functions without using control button.
Control J	Issues line feed only
Control V	Compliment to H <sup>C</sup> . Forward spaces cursor and copies over written characters. Apple keyboards have ">" key on right side which also performs this function.
Control X	Immediately deletes current line.

\* If BASIC program is expecting keyboard input, you will have to hit carriage return key after typing control C.

CHARACTERDESCRIPTION OF ACTION

A <sub>E</sub>	Move cursor to right
B <sub>E</sub>	Move cursor to left
C <sub>E</sub>	Move cursor down
D <sub>E</sub>	Move cursor up
E <sub>E</sub>	Clear text from cursor to end of line
F <sub>E</sub>	Clear text from cursor to end of page
@ <sub>E</sub>	Home cursor to top of page, clear text to end of page.

Table A: APPLE II COLORS AS SET BY COLOR =

Note: Colors may vary depending on TV tint (hue) setting and may also be changed by adjusting trimmer capacitor C3 on APPLE II P.C. Board.

Ø = Black	8 = Brown
1 = Magenta	9 = Orange
2 = Dark Blue	10 = Grey
3 = Light Purple	11 = Pink
4 = Dark Green	12 = Green
5 = Grey	13 = Yellow
6 = Medium Blue	14 = Blue/Green
7 = Light Blue	15 = White



## Special Controls and Features

<u>Hex</u>	<u>BASIC Example</u>	<u>Description</u>
<u>Display Mode Controls</u>		
C050	10 POKE -16304,0	Set color graphics mode
C051	20 POKE -16303,0	Set text mode
C052	30 POKE -16302,0	Clear mixed graphics
C053	40 POKE -16301,0	Set mixed graphics (4 lines text)
C054	50 POKE -16300,0	Clear display Page 2 (BASIC commands use Page 1 only)
C055	60 POKE -16299,0	Set display to Page 2 (alternate)
C056	70 POKE -16298,0	Clear HIRES graphics mode
C057	80 POKE -16297,0	Set HIRES graphics mode
<u>TEXT Mode Controls</u>		
0020	90 POKE 32,L1	Set left side of scrolling window to location specified by L1 in range of 0 to 39.
0021	100 POKE 33,W1	Set window width to amount specified by W1. $L1+W1 < 40$ . $W1 > 0$
0022	110 POKE 34,T1	Set window top to line specified by T1 in range of 0 to 23
0023	120 POKE 35,B1	Set window bottom to line specified by B1 in the range of 0 to 23. $B1 > T1$
0024	130 CH=PEEK(36) 140 POKE 36,CH 150 TAB(CH+1)	Read/set cursor horizontal position in the range of 0 to 39. If using TAB, you must add "1" to cursor position read value; Ex. 140 and 150 perform identical function.
0025	160 CV=PEEK(37) 170 POKE 37,CV 180 VTAB(CV+1)	Similar to above. Read/set cursor vertical position in the range 0 to 23.
0032	190 POKE 50,127 200 POKE 50,255	Set inverse flag if 127 (Ex. 190) Set normal flag if 255(Ex. 200)
FC58	210 CALL -936	(@E) Home cursor, clear screen
FC42	220 CALL -958	(FE) Clear from cursor to end of page

<u>Hex</u>	<u>BASIC Example</u>	<u>Description</u>
FC9C	230 CALL -868	(E) Clear from cursor to end of line
FC66	240 CALL -922	(J) Line feed
FC70	250 CALL -912	Scroll up text one line

### Miscellaneous

C030	360 X=PEEK(-16336) 365 POKE -16336,0	Toggle speaker
C000	370 X=PEEK(-16384)	Read keyboard; if X>127 then key was pressed.
C010	380 POKE -16368,0	Clear keyboard strobe - always after reading keyboard.
C061	390 X=PEEK(16287)	Read PDL(0) push button switch. If X>127 then switch is "on".
C062	400 X=PEEK(-16286)	Read PDL(1) push button switch.
C063	410 X=PEEK(-16285)	Read PDL(2) push button switch.
C058	420 POKE -16296,0	Clear Game I/O AN0 output
C059	430 POKE -16295,0	Set Game I/O AN0 output
C05A	440 POKE -16294,0	Clear Game I/O AN1 output
C05B	450 POKE -16293,0	Set Game I/O AN1 output
C05C	460 POKE -16292,0	Clear Game I/O AN2 output
C05D	470 POKE -16291,0	Set Game I/O AN2 output
C05E	480 POKE -16290,0	Clear Game I/O AN3 output
C05F	490 POKE -16289,0	Set Game I/O AN3 output

## APPLE II BASIC ERROR MESSAGES

- \*\*\* SYNTAX ERR                   Results from a syntactic or typing error.
- \*\*\* > 32767 ERR                   A value entered or calculated was less than -32767 or greater than 32767.
- \*\*\* > 255 ERR                    A value restricted to the range 0 to 255 was outside that range.
- \*\*\* BAD BRANCH ERR               Results from an attempt to branch to a non-existent line number.
- \*\*\* BAD RETURN ERR               Results from an attempt to execute more RETURNS than previously executed GOSUBs.
- \*\*\* BAD NEXT ERR                 Results from an attempt to execute a NEXT statement for which there was not a corresponding FOR statement.
- \*\*\* 16 GOSUBS ERR                Results from more than 16 nested GOSUBs.
- \*\*\* 16 FORS ERR                  Results from more than 16 nested FOR loops.
- \*\*\* NO END ERR                  The last statement executed was not an END.
- \*\*\* MEM FULL ERR                 The memory needed for the program has exceeded the memory size allotted.
- \*\*\* TOO LONG ERR                 Results from more than 12 nested parentheses or more than 128 characters in input line.
- \*\*\* DIM ERR                      Results from an attempt to DIMension a string array which has been previously dimensioned.
- \*\*\* RANGE ERR                    An array was larger than the DIMensioned value or smaller than 1 or HLIN,VLIN, PLOT, TAB, or VTAB arguments are out of range.
- \*\*\* STR OVFL ERR                 The number of characters assigned to a string exceeded the DIMensioned value for that string.
- \*\*\* STRING ERR                  Results from an attempt to execute an illegal string operation.
- RETYPE LINE                 Results from illegal data being typed in response to an INPUT statement. This message also requests that the illegal item be retyped.

# Simplified Memory Map

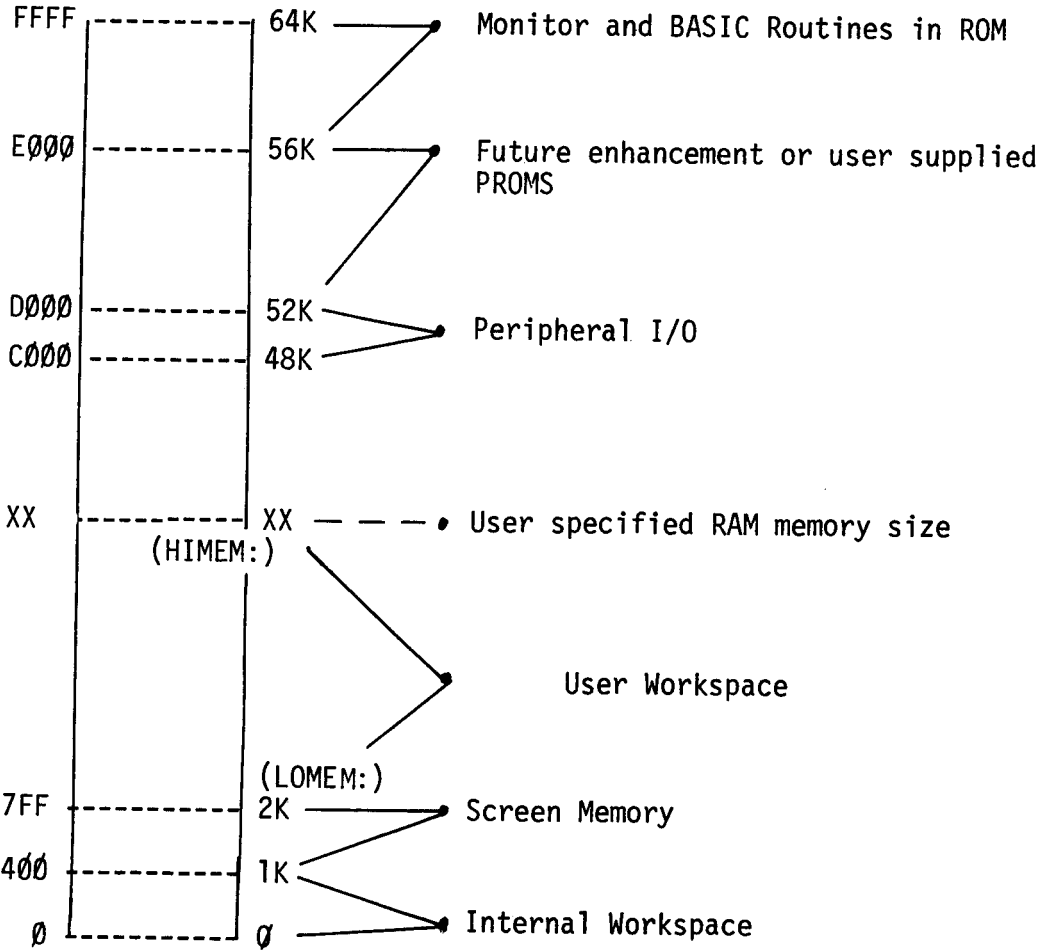

INTRODUCTION

Valuable data can be generated on the Apple II computer and sometimes it is useful to have a software routine that will allow making a permanent record of this information. This paper discusses a simple subroutine that serves this purpose.

Before discussing the Read/Save routines a rudimentary knowledge of how variables are mapped into memory is needed.

Numeric variables are mapped into memory with four attributes. Appearing in order sequentially are the Variable Name, the Display Byte, the Next Variable Address, and the Data of the Variable. Diagrammatically this is represented as:

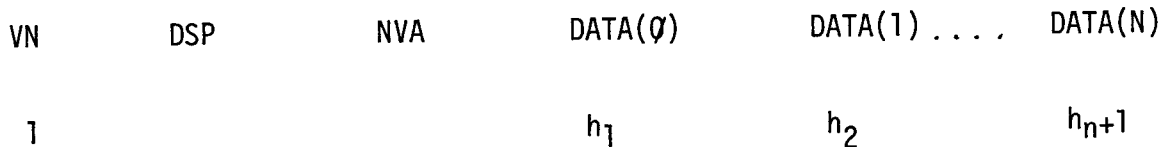

VARIABLE NAME - up to 100 characters represented in memory as ASCII equivalents with the high order bit set.

DSP (DISPLAY) BYTE - set to 01 when DSP set in BASIC initiates a process that displays this variable with the line number every time it is changed within a program.

NVA (NEXT VARIABLE ADDRESS) - two bytes (first low order, the second high order) indicating the memory location of the next variable.

DATA - hexadecimal equivalent of numeric information, represented in pairs of bytes, low order byte first.

String variables are formatted a bit differently than numeric ones. These variables have one extra attribute - a string terminator which designates the end of a string. A string variable is formatted as follows:

VN	DSP	NVA	DATA(0)	DATA(1), . . .	DATA(n)	ST
1			$h_1$	$h_2$	$h_{n+1}$	

VARIABLE NAME - up to 100 characters represented in memory as ASCII equivalents with the high order bit set.

DSP (DISPLAY) BYTE - set to 01 when DSP set in BASIC, initiates a process that displays this variable with the line number every time it is changed within a program.

NVA (NEXT VARIABLE ADDRESS) - two bytes (first low order, the second high order) indicating the memory location of the next variable.

DATA - ASCII equivalents with high order bit set.

STRING TERMINATOR (ST) - none high order bit set character indicating END of string.

There are two parts of any BASIC program represented in memory. One is the location of the variables used for the program, and the other is the actual BASIC program statements. As it turns out, the mapping of these within memory is a straightforward process. Program statements are placed into memory starting at the top of RAM memory\* unless manually shifted by the "HIMEM:" command, and are pushed down as each new (numerically larger) line numbered statement is entered into the system. Figure 1a illustrates this process diagrammatically. Variables on the other hand are mapped into memory starting at the lowest position of RAM memory - hex \$800 (2048) unless manually shifted by the "LOMEM:" command. They are laid down from there (see Figure 1b) and continue until all the variables have been mapped into memory or until they collide with the program statements. In the event of the latter case a memory full error will be generated

\*Top of RAM memory is a function of the amount of memory. ---  
16384 will be the value of "HIMEM:" for a 16K system.

The computer keeps track of the amount of memory used for the variable table and program statements. By placing the end memory location of each into \$CC-CD(204-205) and \$CA-CB(203-204), respectively. These are the BASIC memory program pointers and their values can be found by using the statements in Figure 2. CM defined in Figure 1 as the location of the end of the variable tape is equal to the number resulting from statement a of Figure 2. PP, the program pointer, is equal to the value resulting from statement 2b. These statements(Figure 2) can then be used on any Apple II computer to find the limits of the program and variable table.

#### FINDING THE VARIABLE TABLE FROM BASIC

First, power up the Apple II, reset it, and use the CTRL B (control B) command to place the system into BASIC initializing the memory pointers. Using the statements from Figure 2 it is found that for a 16K Apple II CM is equal to 2048 and PP is equal to 16384. These also happen to be the values of LOMEN and HIMEN: But this is expected because upon using the B<sup>C</sup> command both memory pointers are initialized indicating no program statements and no variables.

To illustrate what a variable table looks like in Apple II memory suppose we want to assign the numeric variable A (\$C1 is the ASCII equivalent of a with the high order bit set) the value of -1 (FF FF in hex) and then examine the memory contents. The steps in this process are outlined in example I. Variable A is defined as equal to -1 (step 1). Then for convenience another variable - B - is defined as equal to 0 (step 2). Now that the variable table has been defined use of statement 2a indicates that CM is equal to 2060 (step 3). LOMEN has not been readjusted so it is equal to 2048. Therefore the variable table resides in memory from 2048 (\$800 hex) to 2060 (\$80C). Depressing the "RESET" key places the Apple II into the monitor mode (step 4).

We are now ready to examine the memory contents of the variable table. Since the variable table resides from \$800 hex to \$80C hex typing in "800.80C" and then depressing the "RETURN" key (step 5) will list the memory contents of this range. Figure 3 lists the contents with each memory location labelled. Examining these contents we see that C1 is equal to the variable name and is the memory equivalent of "A" and that FF FF is the equivalent of -1. From this, since the variable name is at the beginning of the table and the data is at the end, the variable table representation of A extends from \$800 to \$805. We have then found

the memory range of where the variable A is mapped into memory. The reason for this will become clear in the next section.

#### READ/SAVE ROUTINE

The READ/SAVE subroutine has three parts. The first section (lines 0-10) defines variable A and transfers control to the main program. Lines 20 through 26 represents the Write data to tape routine and lines 30-38 represent the Read data from tape subroutine. Both READ and SAVE routines are executable by the BASIC "GOSUB X" (where X is 20 for write and 30 is for read) command. And as listed these routines can be directly incorporated into almost any BASIC program for read and saving a variable table. The limitation of these routines is that the whole part of a variable table is processed so it is necessary to maintain exactly the dimension statements for the variables used.

The variables used in this subroutine are defined as follows:

A = record length, must be the first variable defined  
CM= the value obtained from statement a of figure 2  
LM= is equal to the value of "LOMEM:"  
Nominally 2048

#### SAVING A DATA TABLE

The first step in a hard copy routine is to place the desired data onto tape. This is accomplished by determining the length of the variable table and setting A equal to it. Next within the main program when it is time to write the data a GOSUB20 statement will execute the write to tape process. Record length, variable A, is written to tape first (line 22) followed by the desired data (line 24). When this process is completed control is returned to the main program.

#### READING A DATA TABLE

The second step is to read the data from tape. When it is time a GOSUB30 statement will initiate the read process. First, the record length is read in and checked to see if enough memory is available (line 32-34). If exactly the same dimension statements are used it is almost guaranteed that there will be enough memory available. After this the variable table is read in (line 34) and control is then returned to the main program (line 36). If not enough memory is available then an error is generated and control is returned to the main program (line 38)



## EXAMPLE OF READ/SAVE USAGE

The Read/Save routines may be incorporated directly into a main program. To illustrate this a test program is listed in example 2. This program dimensions a variable array of twenty by one, fills the array with numbers, writes the data table to tape, and then reads the data from tape listing the data on the video display. To get a feeling for how to use these routines enter this program and explore how the Read/Save routines work.

## CONCLUSION

Reading and Saving data in the format of a variable table is a relatively straight forward process with the Read/Save subroutine listed in figure 4. This routine will increase the flexibility of the Apple II by providing a permanent record of the data generated within a program. This program can be reprocessed. The Read/Save routines are a valuable addition to any data processing program.

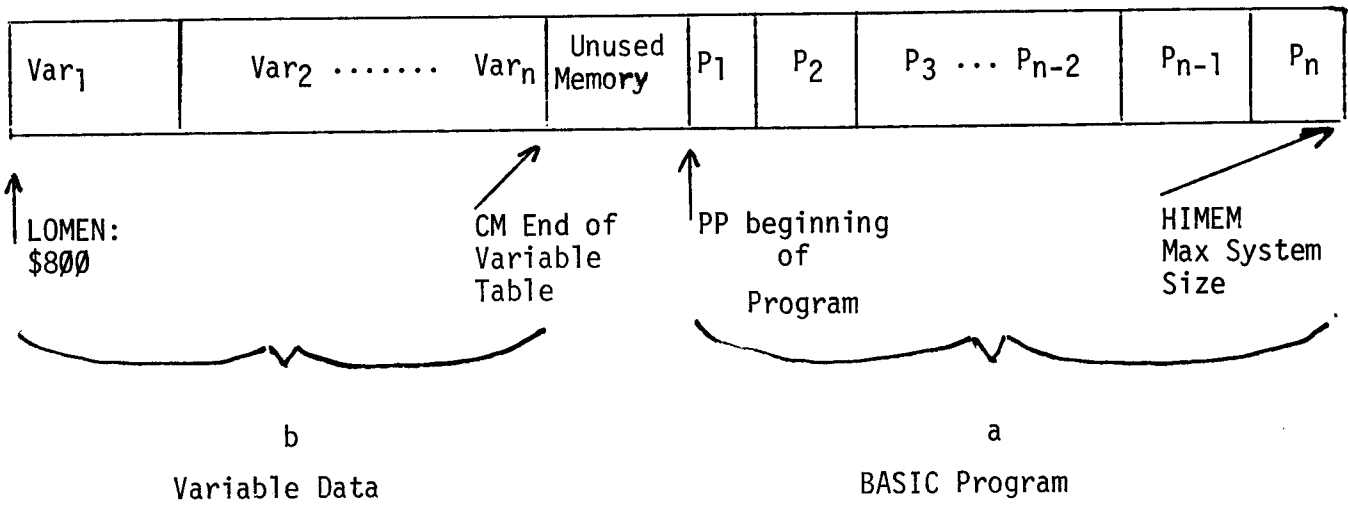

Figure 1

- a) PRINT PEEK(204) + PEEK(205)\*256 → PP
- b) PRINT PEEK(202) + PEEK(203)\*256 → CM

Figure 2

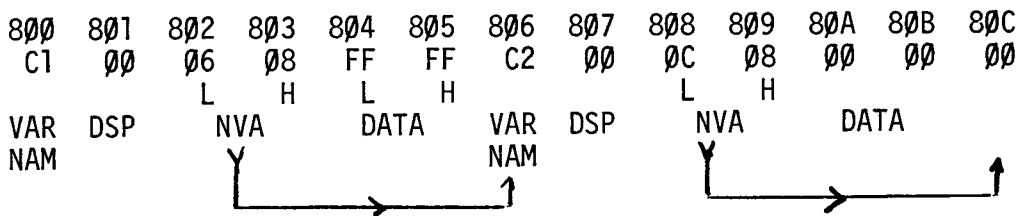

Figure 3  
\$800.80C rewritten with labelling

## READ/SAVE PROGRAM

## COMMENTS

0	A=0	This must be the first statement in the program. It is initially 0, but if data is to be saved, it will equal the length of the data base.
10	GOTO 100	This statement moves command to the main program.
20	PRINT "REWIND TAPE THEN START TAPE RECORDER": INPUT "THEN HIT RETURN", B\$	Lines 20-26 are the write data to tape subroutine.
22	A=CM-LM: POKE 60,4: POKE 61,8: POKE 62,5: POKE 63,8: CALL -307	
24	POKE 60,LM MOD 256: POKE 61, LM/256: POKE 62, CM MOD 256: POKE 63, CM/256: CALL -307	Writing data table to tape
26	PRINT "DATA TABLE SAVED": RETURN	Returning control to main program.
30	PRINT "REWIND THE TAPE THEN START TAPE RECORDER": INPUT "AND HIT RETURN", B\$	Lines 30-38 are the READ data from tape subroutine.
32	POKE 60,4: POKE 61,8: POKE 62,5: POKE 63,8: CALL -259	
34	IF A<0 THEN 38: P=LM+A: IF P>HM THEN 38: CM=P: POKE 60, LM MOD 256: POKE 61, LM/256: POKE 62, CM MOD 256: POKE 63, CM/256: CALL -259	Checking the record length (A) for memory requirements if everything is satisfactory the data is READ in.
36	PRINT "DATA READ IN": RETURN	
38	PRINT "***TOO MUCH DATA BASE***": RETURN	Returning control to main program.

NOTE: CM, LM and A must be defined within the main program.

- |   |  |   |
|---|--|---|
| 1 | >A=1<br>>  | Define variable A=-1, then hit RETURN                     |
| 2 | >B=0<br>>  | Define variable B=0, then hit RETURN                      |
| 3 | >PRINT PEEK (204) + PEEK<br>(205) * 256<br><br>computer responds with=<br>2060 | Use statement 2a to find the end of<br>the VARIABLE TABLE |
| 4 | ><br>*   | Hit the RESET key, Apple moves into<br>Monitor mode.      |
| 5 | *800.80C   | Type in VARIABLE TABLE RANGE and HIT<br>the RETURN KEY.   |

Computer responds with:

```
0800- C1 00 86 08 FF FF C2 00
0808 0C 08 00 00 00
```

Example 1

## Example 2

```

>LIST
  0 A=0
10 GOTO 100
20 REM WRITE DATA TO TAPE ROUTINE
22 A=CH-LN: POKE 60,4: POKE 61
   ,8: POKE 62,5: POKE 63,8: CALL
   -307
24 POKE 60,LM MOD 256: POKE 61
   ,LM/256: POKE 62,CH MOD 256
   : POKE 63,CH/256: CALL -307

26 RETURN
30 REM READ DATA SUBROUTINE
32 POKE 60,4: POKE 61,8: POKE
   62,5: POKE 63,8: CALL -259
34 IF A<0 THEN 30:P=LN+A: IF P>
   HM THEN 30:CH=P: POKE 60,LM MOD
   256: POKE 61,LM/256: POKE 62
   ,CH MOD 256: POKE 63,CH/256
   : CALL -259
36 RETURN
38 PRINT "*** TOO MUCH DATA BASE **
   *": END
100 DIM A$(1),X(20)
105 FOR I=1 TO 20:X(I)=I: NEXT
   I
108 LM=2048:CH=2106:A=58:HM=16383

110 PRINT "20 NUMBERS GENERATED"

120 PRINT "NOW WE ARE GOING TO SAVE
   THE DATA": PRINT "WHEN YOU ARE R
   EADY START THE RECORDER IN RECOR
   D MODE": INPUT "AND HIT RETURN"
   ,A$
130 CALL -936: PRINT "NOW WRITING DA
   TA TO TAPE": GOSUB 20
135 PRINT "NOW THE DATA IS SAVED"

140 PRINT "NOW WE ARE GOING TO CLEAR
   THE X(20) TABLE AND READ THE DA
   TA FROM TAPE"
150 FOR I=1 TO 20:X(I)=0: PRINT
   "X(";I;)"= ";X(I): NEXT I
160 PRINT "NOW START TAPE RECORDER"
   : INPUT "AND THEN HIT RETURN"
   ,A$
165 PRINT "A ",A
170 GOSUB 30
180 PRINT "ALL THE DATA READ IN"

190 FOR I=1 TO 20: PRINT "X(";I;
   ")= ";X(I): NEXT I
195 PRINT "THIS IS THE END"
200 END

```

## A SIMPLE TONE SUBROUTINE

### INTRODUCTION

Computers can perform marvelous feats of mathematical computation at well beyond the speed capable of most human minds. They are fast, cold and accurate; man on the other hand is slower, has emotion, and makes errors. These differences create problems when the two interact with one another. So to reduce this problem humanizing of the computer is needed. Humanizing means incorporating within the computer procedures that aid in a program's usage. One such technique is the addition of a tone subroutine. This paper discusses the incorporation and usage of a tone subroutine within the Apple II computer.

### Tone Generation

To generate tones in a computer three things are needed: a speaker, a circuit to drive the speaker, and a means of triggering the circuit. As it happens the Apple II computer was designed with a two-inch speaker and an efficient speaker driving circuit. Control of the speaker is accomplished through software.

Toggling the speaker is a simple process, a mere PEEK - 16336 (~~\$C030~~) in BASIC statement will perform this operation. This does not, however, produce tones, it only emits clicks. Generation of tones is the goal, so describing frequency and duration is needed. This is accomplished by toggling the speaker at regular intervals for a fixed period of time. Figure 1 lists a machine language routine that satisfies these requirements.

### Machine Language Program

This machine language program resides in page 0 of memory from \$02 (2) to \$14 (20). \$00 (00) is used to store the relative period (P) between toggling of the speaker and \$01 (01) is used as the memory location for the value of relative duration (D). Both P and D can range in value from \$00 (0) to \$FF (255). After the values for frequency and duration are placed into memory a CALL2 statement from BASIC will activate this routine. The speaker is toggled with the machine language statement residing at \$02 and then a

delay in time equal to the value in \$00 occurs. This process is repeated until the tone has lasted a relative period of time equal to the duration (value in \$01) and then this program is exited (statement \$14).

### Basic Program

The purpose of the machine language routine is to generate tones controllable from BASIC as the program dictates. Figure 2 lists the appropriate statement that will deposit the machine language routine into memory. They are in the form of a subroutine and can be activated by a GOSUB 32000 statement. It is only necessary to use this statement once at the beginning of a program. After that the machine language program will remain in memory unless a later part of the main program modifies the first 20 locations of page 0.

After the GOSUB 32000 has placed the machine language program into memory it may be activated by the statement in Figure 3. This statement is also in the form of a GOSUB because it can be used repetitively in a program. Once the frequency and duration have been defined by setting P and D equal to a value between 0 and 255 a GOSUB 25 statement is used to initiate the generation of a tone. The values of P and D are placed into \$00 and \$01 and the CALL2 command activates the machine language program that toggles the speaker. After the tone has ended control is returned to the main program.

The statements in Figures 2 and 3 can be directly incorporated into BASIC programs to provide for the generation of tones. Once added to a program an infinite variety of tone combinations can be produced. For example, tones can be used to prompt, indicate an error in entering or answering questions, and supplement video displays on the Apple II computer system.

Since the computer operates at a faster rate than man does, prompting can be used to indicate when the computer expects data to be entered. Tones can be generated at just about any time for any reason in a program. The programmer's imagination can guide the placement of these tones.

### CONCLUSION

The incorporation of tones through the routines discussed in this paper will aid in the humanizing of software used in the Apple computer. These routines can also help in transforming a dull program into a lively one. They are relatively easy to use and are a valuable addition to any program.

```

0000-   FF           ???
0001-   FF           ???
0002-   AD 30 C0    LDA   $C030
0005-   88           DEY
0006-   D0 04       BNE   $000C
0008-   C6 01       DEC   $01
000A-   F0 08       BEQ   $0014
000C-   CA           DEX
000D-   D0 F6       BNE   $0005
000F-   A6 00       LDX   $00
0011-   4C 02 00    JMP   $0002
0014-   60           RTS

```

FIGURE 1. Machine Language Program adapted from a program by P. Lutas.

```

32000 POKE 2,173: POKE 3,48: POKE
      4,192: POKE 5,136: POKE 6,200
      : POKE 7,4: POKE 8,190: POKE
      9,1: POKE 10,240
32005 POKE 11,8: POKE 12,202: POKE
      13,208: POKE 14,246: POKE 15
      ,166: POKE 16,0: POKE 17,76
      : POKE 18,2: POKE 19,0: POKE
      20,96: RETURN

```

FIGURE 2. BASIC "POKES"

```

25 POKE 0,P: POKE 1,D: CALL 2:
   RETURN

```

FIGURE 3. GOSUB



## High-Resolution Operating Subroutines

These subroutines were created to make programming for High-Resolution Graphics easier, for both BASIC and machine-language programs. These subroutines occupy 757 bytes of memory and are available on either cassette tape or Read-Only Memory (ROM). This note describes use and care of these subroutines.

There are seven subroutines in this package. With these, a programmer can initialize High-Resolution mode, clear the screen, plot a point, draw a line, or draw and animate a predefined shape on the screen. There are also some other general-purpose subroutines to shorten and simplify programming.

BASIC programs can access these subroutines by use of the CALL statement, and can pass information by using the POKE statement. There are special entry points for most of the subroutines that will perform the same functions as the original subroutines without modifying any BASIC pointers or registers. For machine language programming, a JSR to the appropriate subroutine address will perform the same function as a BASIC CALL.

In the following subroutine descriptions, all addresses given will be in decimal. The hexadecimal substitutes will be preceded by a dollar sign (\$). All entry points given are for the cassette tape subroutines, which load into addresses C00 to FFF (hex). Equivalent addresses for the ROM subroutines will be in *italic type face*.

## High-Resolution Operating Subroutines

INIT    Initializes High-Resolution Graphics mode.

From BASIC: CALL 3072 (or CALL -12288)

From machine language: JSR \$C00 (or JSR \$D000)

This subroutine sets High-Resolution Graphics mode with a 280 x 160 matrix of dots in the top portion of the screen and four lines of text in the bottom portion of the screen. INIT also clears the screen.

CLEAR    Clears the screen.

From BASIC: CALL 3086 (or CALL -12274)

From machine language: JSR \$C0E (or JSR \$D00E)

This subroutine clears the High-Resolution screen without resetting the High-Resolution Graphics mode.

PLOT    Plots a point on the screen.

From BASIC: CALL 3780 (or CALL -11580)

From machine language: JSR \$C7C (or JSR \$D07C)

This subroutine plots a single point on the screen. The X and Y coordinates of the point are passed in locations 800, 801, and 802 from BASIC, or in the A, X, and Y registers from machine language. The Y (vertical) coordinate can be from 0

## High-Resolution Operating Subroutines

### PLOT (continued)

(top of screen) to 159 (bottom of screen) and is passed in location 802 or the A-register; but the X (horizontal) coordinate can range from 0 (left side of screen) to 279 (right side of screen) and must be split between locations 800 ( $X \text{ MOD } 256$ ) and 801 ( $X/256$ ). or, from machine language, between registers X (X LO) and Y (X HI). The color of the point to be plotted must be set in location 812 (\$32C). Four colors are possible: 0 is BLACK, 85 (\$55) is GREEN, 170 (\$AA) is VIOLET, and 255 (\$FF) is WHITE.

POSN Positions a point on the screen.

From BASIC: CALL 3761 (or CALL -11599)

From machine language: JSR \$C26 (or JSR \$D026)

This subroutine does all calculations for a PLOT, but does not plot a point (it leaves the screen unchanged). This is useful when used in conjunction with LINE or SHAPE (described later). To use this subroutine, set up the X and Y coordinates just the same as for PLOT. The color in location 812 (\$32C) is ignored.

LINE Draw a line on the screen.

## High-Resolution Operating Routines

LINE Draws a line on the screen.

From BASIC: CALL 3786 (or CALL -11574)

From machine language: JSR \$C95 (or JSR \$D095)

This subroutine draws a line from the last point PLOTTed or POSN'ed to the point specified. One endpoint is the last point PLOTTed or POSN'ed; the other endpoint is passed in the same manner as for a PLOT or POSN. The color of the line is set in location 812 (\$32C). After the line is drawn, the new endpoint becomes the base endpoint for the next line drawn.

SHAPE Draws a predefined shape on the screen.

From BASIC: CALL 3805 (or CALL -11555)

From machine language: JSR \$DBC (or JSR \$D1BC)

This subroutine draws a predefined shape on the screen at the point previously PLOTTed or POSN'ed. The shape is defined by a *table of vectors* in memory. (How to create a vector table will be described later). The starting address of this table should be passed in locations 804 and 805 from BASIC or in the Y and X registers from machine language. The color of the shape should be passed in location 28 (\$1C).

There are two special variables that are used only with shapes: the scaling factor and the rotation factor. The scaling factor determines the relative size of the shape. A scaling factor of

SHAPE (continued)

1 will cause the shape to be drawn true size, while a scaling factor of 2 will draw the shape double size, etc. The scaling factor is passed in location 806 from BASIC or \$32F from machine language. The rotation factor specifies one of 64 possible angles of rotation for the shape. A rotation factor of 0 will cause the shape to be drawn right-side up, where a rotation factor of 16 will draw the shape rotated 90° clockwise, etc. The rotation factor is passed in location 807 from BASIC or in the A-register from machine language.

The table of vectors which defines the shape to be drawn is a series of bytes stored in memory. Each byte is divided into three sections, and each section specifies whether or not to plot a point and also a direction to move (up, down, left, or right). The SHAPE subroutine steps through the vector table byte by byte, and then through each byte section by section. When it reaches a 00 byte, it is finished.

The three sections are arranged in a byte like this:

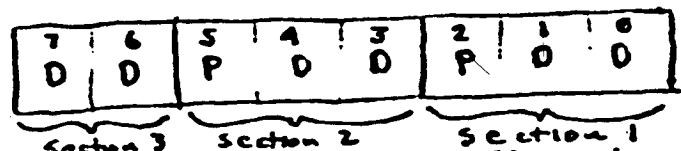

- 00 = 00 Move ↑
- 01   "    →
- 10   "    ↓
- 11   "    ←

Each bit pair DD specifies a direction to move, and the two bits P specify whether or not to plot a point before moving. Notice that the last section (most significant bits) does not have a P field, so it can only be a move without plotting. The SHAPE

SHAPE (continued)

subroutine processes the sections from right to left (least significant bit to most significant bit). IF THE REMAINING SECTIONS OF THE BYTE ARE ZERO, THEN THEY ARE IGNORED. Thus, the byte cannot end with sections of 00 (move up without plotting).

Here is an example of how to create a vector table:

Suppose we want to draw a shape like this:

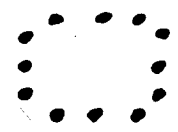

First, draw it on graph paper, one dot per square. Then decide where to start drawing the shape. Let's start this one in the center. Next, we must draw a path through each point in the shape, using only 90° angles on the turns:



Next, re-draw the shape as a series of vectors, each one moving one place up, down, left, or right, and distinguish the vectors that plot a point before moving:



Now "unwrap" those vectors and write them in a straight line.

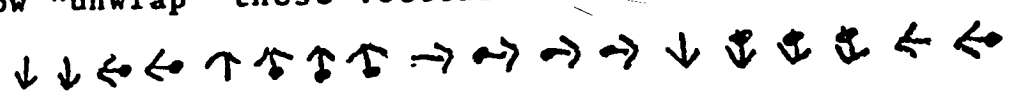

Now draw a table like the one in Figure 1. For each vector in the line, figure the bit code and place it in the next available section in the table. If it will not fit or is a 00 at the end of a byte, then skip that section and go on to the next. When you have finished

## High-Resolution Operating Subroutines

### SHAPE (continued)

coding all vectors, check your work to make sure it is accurate. Then make another table (as in figure 2) and re-copy the coded vectors from the first table. Then decode the vector information into a series of hexadecimal bytes, using the hexadecimal code table in figure 3. This series of hexadecimal bytes is your shape definition table, which you can now put into the Apple II's memory and use to draw that shape on the screen.

Shape vectors: ↓ ↓ ← ← ↑ ↑ ↑ ↑ → → → → ↓ ↓ ↓ ↓ ← ←

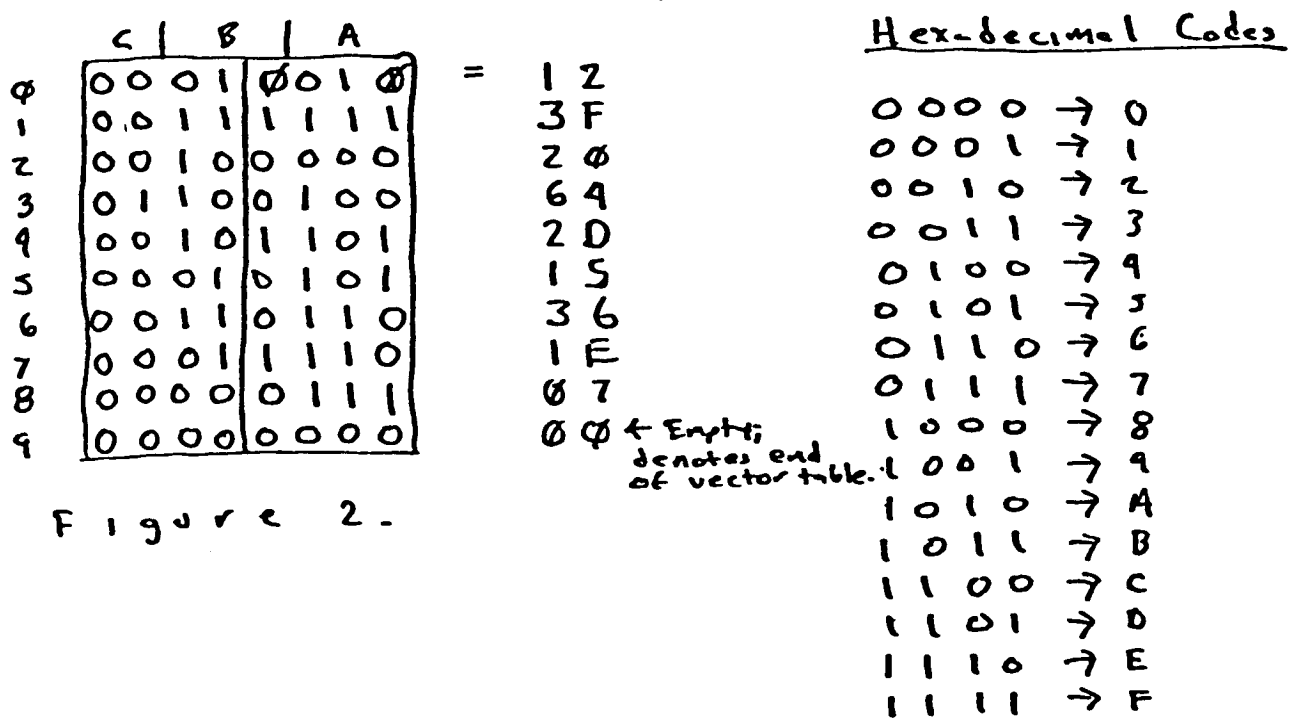
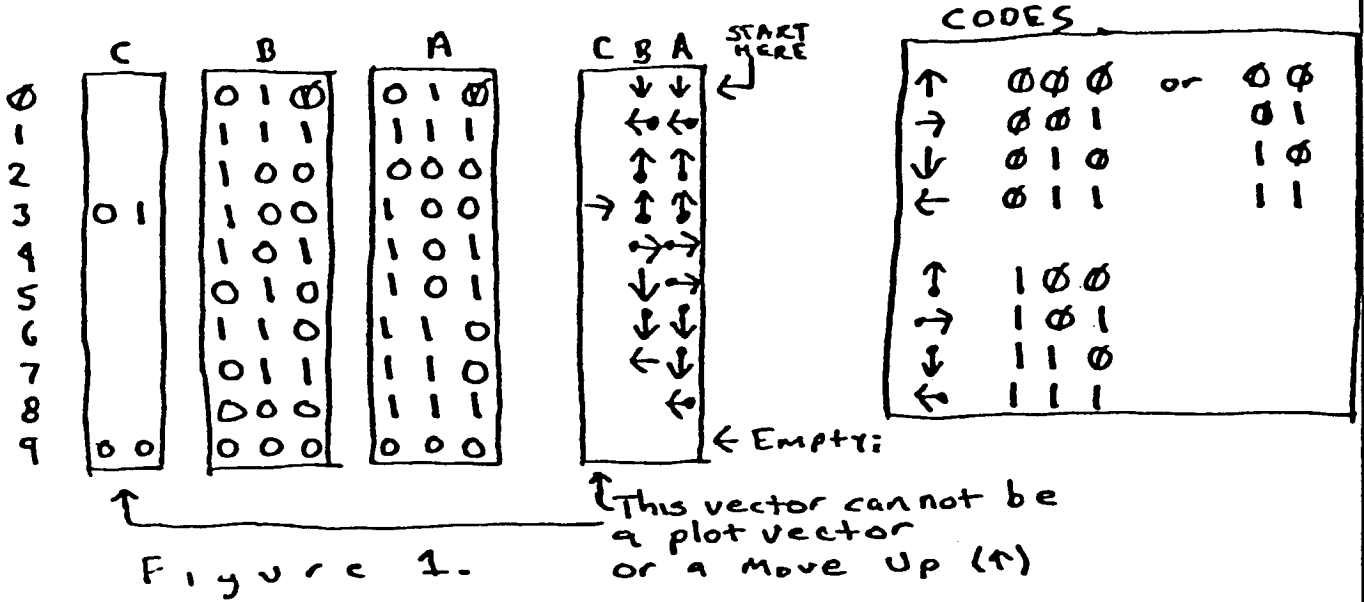



>REM HIRES DEMO-BASIC LISTING

>LIST

```
1 INIT=3072: CLEAR=3086: POSN=3761
: PLOT=3780: LINE=3786: SHAPE=
3005: FIND=3667: SINTBL=3840
5 DIM X(10), Y(10)
10 TEXT : CALL -936: VTAG 4: TAB
10: PRINT "*** 16K APPLE II ***"
: PRINT " *** HIGH RESOLUTION G
GRAPHICS DEMOS ***": PRINT
15 PRINT "1 RANDOM LINE DRAW AT BAS
IC SPEED": PRINT "2 RANDOM SHAPE
PROJECTED INTO CORNER"
20 PRINT "3 CHRIS' MAD FOLLY":
PRINT "4 RANDOM SHAPE SPIRALING
INTO POINT": PRINT "5 SPIROGRAP
H"
25 PRINT "6 HI-RES DONUT": PRINT
"7 RANDOM WAVE FORM": PRINT
"8 SUN OF TWO SINE WAVES"
30 PRINT : PRINT "HIT ANY KEY FOR N
EW DEMO": PRINT "TYPE 'CONTROL C
': RETURN BUTTON THEN TYPE 'T
EXT AND RETURN BUTTON TO STOP"
50 PRINT : INPUT "WHICH DEMO # DO Y
OU WANT ", X1
90 IF X1<1 OR X1>8 THEN 10: CALL
INIT: GOTO 100*X1
100 CALL INIT: X=40: Y=X: GOSUB 2000
: POKE 812,255: CALL PLOT
110 X= RND (200): Y= RND (160): GOSUB
2000: CALL LINE: IF NOT RND
(300) THEN POKE 23,( PEEK (
28)+ RND (3)+1) MOD 4*85: GOSUB
3000: GOTO 110
200 GOSUB 1000: X= RND (2)*279: Y=
RND (2)*159: CALL PLOT: FOR
J=1 TO 30: FOR I=1 TO R: POKE
800,X(I) MOD 256: POKE 801,
X(I)>255: POKE 802,Y(I): CALL
LINE
```

```
530 IF RND (500)<C THEN POKE 28
, RND (4)*85: Y=Y+YDIR*8: IF
Y>=0 AND Y<160 THEN 510: YDIR=
-YDIR: Y=-Y: IF Y<0 THEN Y=Y+
310: GOSUB 3000: GOTO 510
600 POKE -16302,0: POKE 768,5: POKE
769,0: POKE 800,140: POKE 801
,0: POKE 802,0: POKE 804,0:
POKE 805,3: POKE 812,255: CALL
POSN
610 FOR R=0 TO 4160: POKE 807,R MOD
64: POKE 806,2+6* NOT (R MOD
65): CALL SHAPE: NEXT R: GOSUB
3000: GOTO 610
700 J= RND (10)+ RND (10): K= RND
(33)+ RND (31)+ RND (60): L=
RND (9)/8: PRINT "FREQ#1= "
: J;" FREQ#2= ": K
710 GOSUB 4000: GOSUB 3000: GOTO
700
800 INPUT "REL FREQ #1=", J: INPUT
"REL FREQ #2=", K: INPUT "MODE (0
=SOLID, 1=POINTS)", L
810 GOSUB 4000: GOSUB 3000: GOTO
800
1000 CALL CLEAR: POKE 812, RND (
3)*85+85: R= RND (3)+2+ RND
(2): FOR I=1 TO R: X(I)= RND
(160): Y(I)= RND (160): NEXT
I
1010 X=X(I): Y=Y(I): GOSUB 2000: RETURN
2000 POKE 800,X MOD 256: POKE 801
,X>255: POKE 802,Y: RETURN
3000 IF PEEK (-16304)<128 THEN RETURN
: POKE -16368,0: POP : GOTO
10
4000 CALL INIT: POKE 812,255: A=0
: B=0: FOR I=0 TO 279: A=(A+J)
MOD 256: B=(B+K) MOD 256: Y=
( PEEK (SINTBL+A)+ PEEK (SINTBL+
B))*5/16
4010 POKE 800,I MOD 256: POKE 801
,I>255: POKE 802,Y: CALL LINE-
6*( NOT I OR L): NEXT I: RETURN
```

```
210 X(I)=(X(I)-X)*9/10+X: Y(I)=(
Y(I)-Y)*9/10+Y: NEXT I,J: GOSUB
3000: GOTO 200
300 CALL INIT: X= RND (24)*10+20
: Y= RND (14)*10+20: POKE 812
, RND (3)*85+85: GOSUB 2000
: CALL PLOT
310 IF RND (1000)<1 THEN 300: IF
NOT RND (200) THEN POKE 28,
RND (4)*85
320 X1=X+( RND (3)-1)*25: Y1=Y+(
RND (3)-1)*15: IF X1<0 OR
X1>279 OR Y1<0 OR Y1>159 THEN
320
330 X=X1: Y=Y1: GOSUB 2000: CALL
LINE: GOSUB 3000: GOTO 310
400 GOSUB 1000: POKE 812, RND (
3)*85+85: CALL PLOT
410 FOR J=1 TO 25: FOR I=1 TO R:
POKE 800,X(I) MOD 255: POKE
801,X>255: POKE 802,Y(I): CALL
LINE
420 X=(X(I)-80+(Y(I)-80)/8)*9/10
+80: Y(I)=(Y(I)-80-(X(I)-80)
/8)*9/10+80: X(I)=X: NEXT I,
J: GOSUB 3000: GOTO 400
500 CALL INIT: POKE 800,0: CALL
PLOT: X=0: Y=0: XDIR=1: YDIR=1:
A=5: B=3: C=8
510 POKE 800,0: POKE 801,0: POKE
802,Y: CALL LINE: POKE 800,
(279-X) MOD 256: POKE 801,X<
24: POKE 802,159: CALL LINE:
POKE 800,23: POKE 801,1: POKE
802,159-Y: CALL LINE
515 IF RND (500) THEN 520: A=1+ RND
(13): B=2+ RND (3): C=4+ RND
(7)
520 POKE 800,X MOD 256: POKE 801
,X>255: POKE 802,0: CALL LINE:
X=X+XDIR*A: IF X=0 AND X<280
THEN 530: XDIR=-XDIR: X=-X: IF
X<0 THEN X=X+550
```

# ROD'S COLOR PATTERN

## PROGRAM DESCRIPTION

ROD'S COLOR PATTERN is a simple but eloquent program. It generates a continuous flow of colored mosaic-like patterns in a 40 high by 40 wide block matrix. Many of the patterns generated by this program are pleasing to the eye and will dazzle the mind for minutes at a time.

## REQUIREMENTS

4K or greater Apple II system with a color video display.

BASIC is the programming language used.

## PROGRAM LISTING

```
100 GR
105 FOR W=3 TO 50
110 FOR I=1 TO 19
115 FOR J=0 TO 19
120 K=I+J
130 COLOR=J*3/(I+3)+I*W/12
135 PLOT I,K: PLOT K,I: PLOT 40
    -I,40-K
136 PLOT 40-K,40-I: PLOT K,40-I:
    PLOT 40-I,K: PLOT I,40-K: PLOT
    40-K,I
140 NEXT J,I
145 NEXT W: GOTO 105
```

## PROGRAM LISTING: PONG

```

5 REM PONG BY WENDELL BITTER
10 REM      7/7/77
15 REM PADDLE SWITCHES CONTROL
      PADDLE SIZE AFTER A MISS
      OR DURING A HIT
20 GR
25 DIM P(3): DIM HP$(10)
30 A=30:B=1:C=-1
35 COLOR=13: HLIN 1,30 AT 0: HLIN
      1,30 AT 39
40 CALL -936: VTAB 23: INPUT "HAND#
      ALL OR PONG ? ",HP$
45 INPUT "PADDLE SIZE (1-6) ",
      P5: IF P5<1 OR P5>6 THEN 45
      :S=P5-1
50 CALL -936
55 IF HP$(1)="#H" THEN 205
60 H=1: COLOR=13: VLIN 0,39 AT
      39: GOTO 205
65 FOR X=A TO B STEP C
70 Y=YY+V: IF Y>1 AND Y<38 THEN
      80: IF Y<1 THEN Y=1: IF Y>38
      THEN Y=38
75 V=-V: FOR T=1 TO 5:M= PEEK
      (-16336): NEXT T
80 IF X=C OR X=39+C THEN 85: COLOR=
      0: PLOT X-C,Y: COLOR=15: PLOT
      X,Y
85 YY=Y: IF X MOD 2=0 THEN GOSUB
      235: NEXT X
90 GOSUB 235
95 IF SCRN(X,Y+V*(Y+V<40 AND Y+
      V)-1)=0 THEN 165
100 FOR T=1 TO 10:M= PEEK (-16336
      ): NEXT T
105 IF H AND C>0 THEN 130
110 PP=P(X/38)
115 IF Y=PP THEN V=3: IF Y=PP+1
      THEN V=2: IF Y=PP+2 THEN V=
      1
120 IF Y=PP+3 THEN V=-1: IF Y=PP+
      4 THEN V=-2: IF Y=PP+5 THEN
      V=-3
125 IF S=0 THEN V=3- RND (7)
130 COLOR=0: PLOT X-C,Y
135 IF (H AND C>0) OR (VY0= ABS
      (V) AND X=0) THEN V=4- RND
      (9)
140 IF X=0 THEN VY0= ABS (V)
145 A=39-A:B=39-B:C=-C
150 IF PEEK (-16286)>127 AND S#
      5 THEN S=S+1
155 IF PEEK (-16287)>127 AND S#
      0 THEN S=S-1
160 GOTO 65
165 COLOR=0: PLOT X-C,Y
170 COLOR=15: PLOT X,Y+V*(Y+V)-
      1 AND Y+V<40)
175 FOR T=1 TO 75:M= PEEK (-16336
      )+ PEEK (-16336)- PEEK (-16336
      ): NEXT T
180 IF X=0 THEN SR=SR+1: IF X=39
      THEN SL=SL+1
185 VTAB 23: TAB 7: PRINT SL:; TAB
      33: PRINT SR
190 COLOR=0: PLOT X-C,Y
195 IF SL=15 OR SR=15 THEN 260
200 COLOR=0: PLOT X,Y+V*(Y+V)-1
      AND Y+V<40)
205 FOR T=1 TO 75: IF T MOD 5#0
      THEN 210: IF PEEK (-16286)
      >127 AND S#5 THEN S=S+1: IF
      PEEK (-16287)>127 AND S#0 THEN
      S=S-1
210 GOSUB 235: NEXT T
215 YY=P(0): IF X=0 THEN YY=P(1)
      )
220 IF H THEN YY= RND (37)+1
225 V=1- RND (3)
230 GOTO 65
235 IF H THEN 245:P(1)=( PDL (
      1)-24)*20)/115: IF P(1)=P(3
      ) THEN 245: IF P(1)<0 THEN
      P(1)=0: IF P(1)+5>39 THEN P(
      1)=39-5
240 COLOR=6: VLIN P(1),P(1)+5 AT
      39: COLOR=0: IF P(1)>P(3) THEN
      VLIN 0,P(1)-1 AT 39: IF P(1
      )<P(3) THEN VLIN P(1)+5+1,39
      AT 39:P(3)=P(1)
245 P(0)=( PDL (0)-24)*20)/115
      : IF P(0)<0 THEN P(0)=0: IF
      P(0)=P(2) THEN RETURN : IF
      P(0)+5>39 THEN P(0)=39-5
250 COLOR=6: VLIN P(0),P(0)+5 AT
      0: COLOR=0: IF P(0)>P(2) THEN
      VLIN 0,P(0)-1 AT 0: IF P(0)
      <P(2) THEN VLIN P(0)+5+1,39
      AT 0
255 COLOR=0: IF P(0)>P(2) THEN
      VLIN 0,P(0)-1 AT 0: IF P(0)
      <P(2) THEN VLIN P(0)+5+1,39
      AT 0:P(2)=P(0): RETURN
260 PRINT "": END
265 END

```

## COLOR SKETCH

### PROGRAM DESCRIPTION

Color Sketch is a little program that transforms the Apple II into an artist's easel, the screen into a sketch pad. The user as an artist has a 40 high by 40 wide (1600 blocks) sketching pad to fill with a rainbow of fifteen colors. Placement of colors is determined by controlling paddle inputs; one for the horizontal and the other for the vertical. Colors are selected by depressing a letter from A through P on the keyboard.

An enormous number of distinct pictures can be drawn on the sketch pad and this program will provide many hours of visual entertainment.

### REQUIREMENTS

This program will fit into a 4K system in the BASIC mode.

## PROGRAM LISTING: COLOR SKETCH

```

5 POKE 2,173: POKE 3,48: POKE
  4,192: POKE 5,165: POKE 6,0
  : POKE 7,32: POKE 8,168: POKE
  9,252: POKE 10,165: POKE 11
  ,1: POKE 12,288: POKE 13,4
10 POKE 14,198: POKE 15,24: POKE
  16,240: POKE 17,5: POKE 18,
  198: POKE 19,1: POKE 20,76:
  POKE 21,2: POKE 22,8: POKE
  23,96
15 DIM B$(40): TEXT : CALL -936
  : GOTO 90
20 CALL -936: GOTO 90
25 A= LEN(B$): FOR Z=1 TO A: GOSUB
  65: PRINT B$(Z,Z): NEXT Z:
  GOSUB 70: RETURN
30 B$="*****": RETURN
  *****": RETURN
35 B$="COLOR SKETCH": RETURN
40 B$="COPYRIGHT APPLE COMPUTER 197
  7": RETURN
45 B$="THIS PROGRAM ALLOWS YOU TO "
  : RETURN
50 B$="SKETCH COLORED FIGURES IN"
  : RETURN
55 B$="LOW RESOLUTION GRAPHICS WITH
  PADDLES": RETURN
60 KK=20:TON=20: GOSUB 85: RETURN
65 KK=10:TON=10: GOSUB 85: RETURN
70 KK=20:TON=50: GOSUB 85:KK=30
  :TON=90: GOSUB 85: RETURN
75 KK=20:TON=20: GOSUB 85: RETURN
80 KK=8:TON=250: GOSUB 85:KK=9
  :TON=250: GOSUB 85: RETURN
85 POKE 1,TON MOD 256: POKE 24
  ,TON/256+1: POKE 0,KK: CALL
  2: RETURN
90 GOSUB 30: GOSUB 25: PRINT :
  TAB 13: GOSUB 35: GOSUB 25
  : PRINT : GOSUB 30: GOSUB 25
  : PRINT : TAB 5: GOSUB 40: GOSUB
  25: PRINT : GOSUB 30: GOSUB
  25
95 PRINT : GOSUB 70: GOSUB 45:
  GOSUB 25: PRINT : GOSUB 50
  : GOSUB 25: PRINT : GOSUB 55
  : GOSUB 25: PRINT
100 PRINT : PRINT : GOSUB 70: INPUT
  "WHEN READY HIT RETURN",B$
105 GR
110 B$="ABCDEFGHIJKLMNPO": CALL
  -936
115 FOR Z=0 TO 15: COLOR=Z: PLOT
  Z*2+4,39: VTAB 21: GOSUB 75
  : TAB Z*2+5: PRINT B$(Z+1,Z+
  1): GOSUB 75: NEXT Z: TAB
  1
120 VTAB 22:B$="TYPE A LETTER TO CH
  ANGE COLOR.": GOSUB 25: PRINT
  :B$="TYPE SPACE BAR TO STOP PLOT
  .": GOSUB 25: PRINT
125 Y= PDL (1)*39/255:X= PDL (0
  )*39/255: VTAB 24: TAB 1: PRINT
  "CURSOR POSITION: X=";X;" Y="
  ;Y;" "":
130 IF PEEK (-16384)>127 THEN 145
  : IF X1=X AND Y1=Y THEN 125
  : COLOR=C2: PLOT X1,Y1: IF
  NOT FLAG THEN 135: COLOR=C:
  PLOT X,Y
135 C2= SCRNX,Y):C3=15: IF C2=
  15 THEN C3=5: COLOR=C3: PLOT
  X,Y:X1=X:Y1=Y
140 GOTO 125
145 IF PEEK (-16384)#160 THEN 155
  :FLAG=0: POKE -16368,0: POKE
  34,20: COLOR=0: HLIN 0,39 AT
  39: CALL -936
150 PRINT :B$="CONTINUE OR STOP"
  : VTAB 24: GOSUB 25: INPUT
  " (C/S) ",B$: IF B$(1,1)="C"
  THEN 110: PRINT "END": END
155 FLAG=1:C= PEEK (-16384)-193
  : POKE -16368,0: GOTO 125

```

## MASTERMIND PROGRAM

### PROGRAM DESCRIPTION

MASTERMIND is a game of strategy that matches your wits against Apple's. The object of the game is to choose correctly which 5 colored bars have been secretly chosen by the computer. Eight different colors are possible for each bar - Red (R), Yellow (Y), Violet (V), Orange (O), White (W), and Black (B). A color may be used more than once. Guesses for a turn are made by selecting a color for each of the five hidden bars. After hitting the RETURN key Apple will indicate the correctness of the turn. Each white square to the right of your turn indicates a correctly colored and positioned bar. Each grey square acknowledges a correctly colored but improperly positioned bar. No squares indicate you're way off.

Test your skill and challenge the Apple II to a game of MASTERMIND.

### REQUIREMENTS

8K or greater Apple II computer system.

BASIC is the programming language.

PROGRAM LISTING: MASTERMIND

```

0 REM GAME OF MASTERMIND 8-25-77
WOZ (APPLE COMPUTER)
10 DIM A(6),C(8),D(5),X(8),X$(
8):X(1)=2:X(2)=12:X(3)=1:X(
4)=13:X(5)=3:X(6)=9:X(7)=15
:X(8)=5:X$="BGRIYVOWX"
20 TEXT : CALL -936: PRINT "

WELCO
ME TO THE GAME OF MASTERMIND!

YOUR OBJECT IS TO GUESS 5 COLOR
S (WHICH"
30 PRINT "I WILL MAKE UP) IN THE MI
NIMUM NUMBER OF GUESSES. THER
E ARE EIGHT DIFFERENT COLORS TO
CHOSE FROM."
40 PRINT "

FEWER THAN 7 GUESSES--EXC
ELLENT": PRINT " 7 TO 9 GUESSE
S----GOOD": PRINT " 10 TO 14 G
UESSES----AVERAGE"
50 PRINT "MORE THAN 14 GUESSES--POO
R

": CALL -384: TAB 7: PRINT
"HIT ANY KEY TO BEGIN PLAY"

100 CALL -380: IF PEEK (-16384)
<132 THEN 100: POKE -16368,
0: GR : PRINT : FOR I=1 TO
8:C(I)= RND (8)+1: COLOR=X(
I): HLIN I*4-2,I*4 AT 39: PRINT
" :X$(I,I): NEXT I
110 TRY=0: PRINT : PRINT " LETTER
KEYS FOR COLOR CHANGE": PRINT
" ARROW KEYS FOR ADVANCE AND BA
CK": PRINT " HIT RETURN TO ACC
EPT GUESS #";

200 Y=TRY*2 MOD 36+1:TRY=TRY+1:
TAB 32: PRINT TRY;: COLOR=
0: HLIN 0,39 AT Y:FLASH=1: FOR
N=1 TO 5:R(N)=8: GOSUB 1000
: NEXT N:N=1
300 FOR WAIT=1 TO 10:KEY= PEEK
(-16384): IF KEY<132 THEN 310
: POKE -16368,0:FLASH=1: FOR
I=1 TO 8: IF KEY<> ASC(X$(I)
) THEN NEXT I: IF I=9 THEN
310:R(N)=I:KEY=149
310 GOSUB 1000: IF KEY=141 THEN
400: IF KEY=136 AND N>1 OR
KEY=149 AND N<6 THEN N=N+KEY/
5-28: NEXT WAIT:FLASH=1-FLASH:
GOTO 300
400 COLOR=15:N=0: FOR I=1 TO 5:
D(I)=C(I):J=1: GOSUB 2000: NEXT
I: IF N=5 THEN 500: COLOR=5
: FOR J=1 TO 5: FOR I=1 TO
5: GOSUB 2000: NEXT I,J: GOTO
200
500 PRINT : PRINT "
YOU GOT IT IN "
:TRY;" TRIES (";: IF TRY<7 THEN
PRINT "EXCELLENT";: IF TRY>
6 AND TRY<10 THEN PRINT "GOOD"
;
510 IF TRY>9 AND TRY<15 THEN PRINT
"AVERAGE";: IF TRY>14 THEN
PRINT "POOR";: PRINT "): CALL
-384: TAB 5: PRINT "HIT ANY KEY
TO PLAY AGAIN": GOTO 100
1000 IF N=6 THEN RETURN : COLOR=
X(R(N))*FLASH: HLIN N*4-2,N*
4 AT Y: RETURN
2000 IF A(I)<>D(J) THEN RETURN :
N=N+1: PLOT 21+N,N,Y: PRINT
":::A(I)=0:D(J)=9: RETURN
3000 REM CALL -384 SETS INVERSE VID
3010 REM CALL -380 SETS NORMAL VID
3020 REM PEEK(-16384) IS KBD (ASCII)
(IF > 127 THEN STROBE SET)
3030 REM POKE-16368 CLR5 KBD STROBE
3040 REM CALL-936 CLEARS SCREEN AND
TABS CURSOR TO UPPER LEFT.
3050 REM IN 310, KEY/5-28= -1 OR +1
(ARROW KEY=136 OR 149 ASCII)
4000 REM STMTS 10-50 INTRO
4010 REM STMTS 100-110 NEW SETUP
4020 REM STMT 200 NEW GUESS
4030 REM STMTS 300-310 USER INPUT
4040 REM STMT 400 GUESS EVAL
4050 REM STMTS 500-510 WIN
4060 REM SUBR 1000 COLOR LINE
4070 REM SUBR 2000 MATCH TEST

```

# BIORHYTHM PROGRAM

## PROGRAM DESCRIPTION

This program plots three Biorhythm functions: Physical (P), Emotional (E), and Mental (M) or intellectual. All three functions are plotted in the color graphics display mode.

Biorhythm theory states that aspects of the mind run in cycles. A brief description of the three cycles follows:

### Physical

The Physical Biorhythm takes 23 days to complete and is an indirect indicator of the physical state of the individual. It covers physical well-being, basic bodily functions, strength, coordination, and resistance to disease.

### Emotional

The Emotional Biorhythm takes 28 days to complete. It indirectly indicates the level of sensitivity, mental health, mood, and creativity.

### Mental

The mental cycle takes 33 days to complete and indirectly indicates the level of alertness, logic and analytic functions of the individual, and mental receptivity.

### Biorhythms

Biorhythms are thought to affect behavior. When they cross a "baseline" the functions change phase - become unstable - and this causes Critical Days. These days are, according to the theory, our weakest and most vulnerable times. Accidents, catching colds, and bodily harm may occur on physically critical days. Depression, quarrels, and frustration are most likely on emotionally critical days. Finally, slowness of the mind, resistance to new situations and unclear thinking are likely on mentally critical days.

## REQUIREMENTS

This program fits into a 4K or greater system.

BASIC is the programming language used.



## PROGRAM LISTING: BIORHYTHM

```

5 POKE 2,173: POKE 3,48: POKE      70 POKE 1,TH MOD 256: POKE 24,      110 J=1: GR : POKE 34,23: FOR X=
  4,192: POKE 5,165: POKE 6,0          TH/256+1: POKE 0,KK: CALL 2          10 TO 20: COLOR=3: HLINE 0,31
: POKE 7,32: POKE 8,168: POKE          : RETURN          AT X: NEXT X: HLINE 1,3 AT
9,252: POKE 10,165: POKE 11          75 GOSUB 60: INPUT "DATE (M,D,Y) "      3: HLINE 1,3 AT 37: VLINE 2,4
,1: POKE 12,200: POKE 13,4            ,M,D,Y:Y=Y+(Y(100)*1900          AT 2: VTAB 21
10 POKE 14,198: POKE 15,24: POKE      80 A=Y-(M(3):N=Y MOD 59*365-Y/      115 FOR Y=1 TO 31 STEP 3: PRINT
  16,240: POKE 17,5: POKE 18,          59*82+A/4-A/400+M*31-M/12-M/      Y: IF Y(10 THEN PRINT ". ";
  198: POKE 19,1: POKE 20,76:        7-N/5-3*(N)2)+D: IF N(0 THEN      : PRINT " ";; NEXT Y: PRINT
  POKE 21,2: POKE 22,0: POKE          N=N+21252: RETURN          " P E M": VTAB 24
  23,96
15 GOTO 85
20 TT=3: GOSUB 30: RETURN
25 PRINT "*****
*****": RETURN
30 KK=8:TON=500: GOSUB 45: RETURN
35 KK=8:TON=250: GOSUB 45: RETURN
40 KK=8:TON=250: GOSUB 45:KK=9
:TON=250: GOSUB 45: RETURN
45 POKE 1,TON MOD 256: POKE 24
,TON/256+1: POKE 0,KK: CALL
2: RETURN
50 A=(19-(P*B(I)/100))*(P*100<
C(I))+(P*100>C(I))*(P*100<=
3*C(I))*(P*100-C(I))/100*B(
I)/100)
55 A=A+(P*100)>3*C(I))*(30-((P*
100-3*C(I))/100*B(I)/100)):
A=39*(A/39)+A*(A(40): RETURN
60 KK=8:TH=500: GOSUB 70:KK=9:
TH=250: GOSUB 70: RETURN
65 KK=7:TH=10: GOSUB 70: RETURN
70 POKE 1,TH MOD 256: POKE 24,
TH/256+1: POKE 0,KK: CALL 2
: RETURN
75 GOSUB 60: INPUT "DATE (M,D,Y) "
,M,D,Y:Y=Y+(Y(100)*1900
80 A=Y-(M(3):N=Y MOD 59*365-Y/
59*82+A/4-A/400+M*31-M/12-M/
7-N/5-3*(N)2)+D: IF N(0 THEN
N=N+21252: RETURN
85 DIM N$(10),B$(3),C(3),
BV(3):B(1)=348:B(2)=266:B(3
)=242:C(1)=575:C(2)=700:C(3
)=825:BV(1)=23:BV(2)=28
90 BV(3)=33: TEXT : CALL -936:
POKE 34,20: GOSUB 20: GOSUB
25: GOSUB 20: PRINT : TAB 10
: PRINT "APPLE II BIORHYTHM (4K)
": TAB 15: PRINT
95 GOSUB 25: TAB 5: PRINT "COPYRIGH
T 1977 APPLE COMPUTER INC."
: POKE 34,24: VTAB 24
100 GOSUB 60: INPUT "NAME ",N$:
VTAB 22: PRINT N$: VTAB 24
: PRINT "BIRTH ";; GOSUB 75
: VTAB 22: TAB 21: PRINT "BIRTH
DATE ";N;"",",D";",",Y: VTAB
24:W1=H: CALL -868
105 PRINT "FORECAST ";; GOSUB 75
:N=N-W1: IF N(0 THEN N=N+21252
: VTAB 23: TAB 18: PRINT "FORECA
ST DATE ";N;"",",D";",",Y: VTAB
24: CALL -868
110 J=1: GR : POKE 34,23: FOR X=
10 TO 20: COLOR=3: HLINE 0,31
AT X: NEXT X: HLINE 1,3 AT
3: HLINE 1,3 AT 37: VLINE 2,4
AT 2: VTAB 21
115 FOR Y=1 TO 31 STEP 3: PRINT
Y: IF Y(10 THEN PRINT ". ";
: PRINT " ";; NEXT Y: PRINT
" P E M": VTAB 24
120 VTAB 23: PRINT "DAYS LIVED "
;N: FOR I=1 TO 3: COLOR=1+(
I-1)+6*(I-2)+8*(I-3): VLINE
0,39 AT 33+I+I: VTAB 24
125 FOR X=0 TO 31:P=(N MOD BV(I)
+X) MOD BV(I): GOSUB 50: PLOT
X,A: GOSUB 65: NEXT X: NEXT
I
130 PRINT : INPUT "ANOTHER PLOT (Y/N
)",B$: IF B$(1,1)="Y" THEN
90: END

```

## DRAGON MAZE PROGRAM

### PROGRAM DESCRIPTION

DRAGON MAZE is a game that will test your skill and memory. A maze is constructed on the video screen. You watch carefully as it is completed. After it is finished the maze is hidden as if the lights were turned out. The object of the game is to get out of the maze before the dragon eats you. A reddish-brown square indicates your position and a purple square represents the dragon's.\* You move by hitting a letter on the keyboard; U for up, D for down, R for right, and L for left. As you advance so does the dragon. The scent of humans drives the dragon crazy; when he is enraged he breaks through walls to get at you. DRAGON MAZE is not a game for the weak at heart. Try it if you dare to attempt out-smarting the dragon.

### REQUIREMENTS

8K or greater Apple II computer system.

BASIC is the programming language.

\* Color tints may vary depending upon video monitor or television adjustments.

PROGRAM LISTING: DRAGON MAZE

```

1 TEXT : CALL -936
2 PRINT "WELCOME TO THE DRAGON'S MAZE!"
3 PRINT "YOU MAY WATCH WHILE I BUILD A MAZE,"
4 PRINT "BUT WHEN IT'S COMPLETE, I'LL ERASE"
5 PRINT "THE PICTURE. THEN YOU'LL ONLY SEE THE WALLS AS YOU BUMP INTO THEM."
6 PRINT "TO MOVE, YOU HIT 'R' FOR RIGHT,"
7 PRINT "'L' FOR LEFT, 'U' FOR UP, AND 'D' FOR DOWN. DO NOT HIT RETURN!"
9 PRINT
10 PRINT "THE OBJECT IS FOR YOU (THE GREEN DOT)"
11 PRINT "TO GET TO THE DOOR ON THE RIGHT SIDE"
12 PRINT "BEFORE THE DRAGON (THE RED DOT) EATS"
13 PRINT "YOU."
14 PRINT "BEWARE!!!!!!!!!! SOMETIMES THE DRAGON"
15 PRINT "GETS REAL MAD, AND CLIMBS OVER A WALL."
16 PRINT "BUT MOST OF THE TIME, HE CAN'T GO OVER"
17 PRINT "AND HAS TO GO AROUND."
18 PRINT
19 PRINT "(HINT: YOU CAN OFTEN TELL WHERE A WALL"
20 PRINT "IS, EVEN BEFORE YOU CAN SEE IT, BY"
21 PRINT "THE FACT THAT THE DRAGON CAN'T GET"
22 PRINT "THROUGH IT!)"
23 PRINT
89 DIM A$(3)
90 PRINT "TYPE 'GO' TO BEGIN "
   : INPUT A$
100 GR : COLOR=15
105 CALL -936: PRINT "DRAGON MAZE"
   : TAB (25): PRINT "GARY J. SHANON"
110 FOR I=0 TO 39 STEP 3: VLIN 0,39 AT I: HLIN 0,39 AT I: NEXT I
120 COLOR=0
130 S=1000
1000 DIM M(169),T(169)
1001 FOR I=1 TO 169:T(I)=0: NEXT I
1010 FOR I=1 TO 169:M(I)=11: NEXT I
1020 X= RND (13)+1:Y= RND (13)+1 :C=169
1035 IF C=1 THEN 1200
1040 R=0:D=0:L=0:U=0:K=X+13*(Y-1):M(K)-- ABS (M(K)):C=C-1
1050 IF X=13 THEN 1060:R=M(K+1)>0
1060 IF Y=13 THEN 1070:D=M(K+13)>0
1070 IF X=1 THEN 1080:L=M(K-1)>0
1080 IF Y=1 THEN 1090:U=M(K-13)>0
1090 Q=R+D+L+U
1100 IF (Q<3 AND RND (10)<2) OR Q=0 THEN 1170
1110 DR= RND (4)
1120 GOTO 1130+10*DR
1130 IF NOT R THEN 1110:M(K)=M(K)+1:X=X+1
1135 VLIN 3*Y-2,3*Y-1 AT 3*(X-1)
1136 GOTO 1035
1140 IF NOT D THEN 1110:M(K)=M(K)+10:Y=Y+1
1145 HLIN 3*X-2,3*X-1 AT 3*(Y-1)
1146 GOTO 1035
1150 IF NOT L THEN 1110:M(K-1)=M(K-1)-1:X=X-1
1155 VLIN 3*Y-2,3*Y-1 AT 3*X
1156 GOTO 1035
1160 IF NOT U THEN 1110:M(K-13)=M(K-13)-10:Y=Y-1
1165 HLIN 3*X-2,3*X-1 AT 3*Y: GOTO 1035
1170 X= RND (13)+1:Y= RND (13)+1
1180 IF M(X+13*(Y-1))>0 THEN 1170
1190 C=C+1: GOTO 1035
1200 GOSUB 5000: PRINT "THE MAZE IS READY"
1205 GR : COLOR=15
1210 VLIN 0,39 AT 0: VLIN 0,39 AT 39: HLIN 0,39 AT 0: HLIN 0,39 AT 39
1220 X=1:Y= RND (13)+1: COLOR=8: PLOT 3*X-2,3*Y-2

```

DRAGON MAZE cont.

```

1225 HX=3*X-2:HY=3*Y-2
1230 WY= RND (13)+1
1240 COLOR=0: VLIN 3*WY-2,3*WY-1
      AT 39
1250 SX=13:SY=WY
1260 QX=3*SX-2:QY=3*SY-2
1270 RD=1
1500 K= PEEK (-16384): IF K<128 THEN
      1500
1510 POKE -16388,0
1515 Q0=K: GOSUB 7000:K=Q0
1516 IF SX=X AND SY=Y THEN 8000
1520 IF K= ASC("R") THEN 2000
1530 IF K= ASC("L") THEN 2500
1540 IF K= ASC("U") THEN 3000
1550 IF K= ASC("D") THEN 3500
1560 GOSUB 5000: GOTO 1500
2000 DX=1:DY=0
2010 IF M(X+13*(Y-1)) MOD 10 THEN
      4000
2020 FX=3*X-2:FY=3*Y-2: FOR I=1 TO
      3
2030 FX=FX+DX:FY=FY+DY
2040 COLOR=0
2060 FOR K=0 TO 1: FOR L=0 TO 1:
      PLOT HX+K,HY+L: NEXT L,K: COLOR=
      0: FOR K=0 TO 1: FOR L=0 TO
      1: PLOT FX+K,FY+L: NEXT L,K:
      HX=FX:HY=FY
2110 NEXT I
2115 X=X+DX:Y=Y+DY
2116 IF X=13 AND Y=WY THEN 6000
2120 GOTO 1500
2500 DX=-1:DY=0
2510 IF M(X+13*(Y-1)-1) MOD 10 THEN
      4100
2520 GOTO 2020
3000 DX=0:DY=-1
3010 IF M(X+13*(Y-2))/10 THEN 4200
3020 GOTO 2020
3500 DX=0:DY=1
3510 IF M(X+13*(Y-1))/10 THEN 4300
3520 GOTO 2020
4000 GOSUB 5000
4010 COLOR=15
4020 VLIN 3*(Y-1),3*Y AT 3*X
4030 GOTO 1500
4100 GOSUB 5000
4110 COLOR=15
4120 VLIN 3*(Y-1),3*Y AT 3*(X-1)
4130 GOTO 1500
4200 GOSUB 5000
4210 COLOR=15
4220 HLIN 3*(X-1),3*X AT 3*(Y-1)
4230 GOTO 1500
4300 GOSUB 5000
4310 COLOR=15
4320 HLIN 3*(X-1),3*X AT 3*Y
4330 GOTO 1500
5000 S=5-1: FOR I=1 TO 20:A= PEEK
      (-16336)+ PEEK (-16336)+ PEEK
      (-16336)+ PEEK (-16336): NEXT
      I: RETURN
6000 PRINT "YOU WIN!"
6010 GOSUB 5000: GOSUB 5000: GOSUB
      5000
6020 PRINT "SCORE=";S+3
6030 END
7000 IF X>SX THEN 7005: IF Y>SY THEN
      7050
7001 IF X<SX THEN 7100: IF Y<SY THEN
      7150
7005 IF SX=13 THEN 7050: IF T(SX+
      13*(SY-1))>9 THEN 7010: IF
      M(SX+13*(SY-1)) MOD 10 THEN
      7050
7010 DX=1:DY=0
7020 COLOR=0
7022 RX=3*SX-2:RY=3*SY-2
7023 FOR I=1 TO 3:RX=RX+DX:RY=RY+
      DY
7024 COLOR=0
7025 FOR K=0 TO 1: FOR L=0 TO 1:
      PLOT QX+K,QY+L: NEXT L,K: COLOR=
      RD: FOR K=0 TO 1: FOR L=0 TO
      1: PLOT RX+K,RY+L: NEXT L,K:
      QX=RX:QY=RY
7030 NEXT I
7035 SX=SX+DX:SY=SY+DY
7040 T(SX+13*(SY-1))=T(SX+13*(SY-
      1))+1
7045 RETURN
7050 IF SY=13 THEN 7100: IF T(SX+
      13*(SY-1))>9 THEN 7060: IF
      M(SX+13*(SY-1))/10 THEN 7100
7060 DX=0:DY=1: GOTO 7020
7100 IF SX=1 THEN 7150: IF T(SX+
      13*(SY-1))>9 THEN 7110: IF
      M(SX+13*(SY-1)-1) MOD 10 THEN
      7150

```

DRAGON MAZE cont.

```
7110 DX=-1:DY=0: GOTO 7020
7150 IF SY=1 THEN 7005: IF (SX+
    13*(SY-1))>9 THEN 7160: IF
    ((SX+13*(SY-1)-13)/10 THEN
    7005
7160 DX=0:DY=-1: GOTO 7020
8000 GOSUB 5000: GOSUB 5000: GOSUB
    5000: GOSUB 5000: PRINT "THE DRA
    GON GOT YOU!"
1999 END
```

>

# APPLE II FIRMWARE

1. System Monitor Commands
2. Control and Editing Characters
3. Special Controls and Features
4. Annotated Monitor and Dis-assembler Listing
5. Binary Floating Point Package
6. Sweet 16 Interpreter Listing
7. 6502 Op Codes

## System Monitor Commands

Apple II contains a powerful machine level monitor for use by the advanced programmer. To enter the monitor either press RESET button on keyboard or CALL-151 (Hex FF65) from Basic. Apple II will respond with an "\*" (asterisk) prompt character on the TV display. This action will not kill current BASIC program which may be re-entered by a CC (control C). NOTE: "adrs" is a four digit hexadecimal number and "data" is a two digit hexadecimal number. Remember to press "return" button at the end of each line.

<u>Command Format</u>	<u>Example</u>	<u>Description</u>
<u>Examine Memory</u>		
adrs	*C0F2	Examines (displays) single memory location of (adrs)
adrs1.adrs2	*1024.1048	Examines (displays) range of memory from (adrs1) thru (adrs2)
(return)	* (return)	Examines (displays) next 8 memory locations.
.adrs2	*.4096	Examines (displays) memory from current location through location (adrs2)
<u>Change Memory</u>		
adrs:data data data	*A256:EF 20 43	Deposits data into memory starting at location (adrs).
:data data data	*:F0 A2 12	Deposits data into memory starting after (adrs) last used for deposits.
<u>Move Memory</u>		
adrs1<adrs2. adrs3M	*100<B010.B410M	Copy the data now in the memory range from (adrs2) to (adrs3) into memory locations starting at (adrs1).
<u>Verify Memory</u>		
adrs1<adrs2. adrs3V	*100<B010.B410V	Verify that block of data in memory range from (adrs2) to (adrs3) exactly matches data block starting at memory location (adrs1) and displays differences if any.

<u>Command Format</u>	<u>Example</u>	<u>Description</u>
<u>Cassette I/O</u>		
adrs1.adrs2R	*300.4FFR	Reads cassette data into specified memory (adrs) range. Record length must be same as memory range or an error will occur.
adrs1.adrs2W	*800.9FFW	Writes onto cassette data from specified memory (adrs) range.
<u>Display</u>		
I	*I	Set inverse video mode. (Black characters on white background)
N	*N	Set normal video mode. (White characters on black background)
<u>Dis-assembler</u>		
adrsL	*C800L	Decodes 20 instructions starting at memory (adrs) into 6502 assembly mnemonic code.
L	*L	Decodes next 20 instructions starting at current memory address.
<u>Mini-assembler</u>		
(Turn-on)	*F666G	Turns-on mini-assembler. Prompt character is now a "!" (exclamation point).
\$(monitor command)	!\$C800L	Executes any monitor command from mini-assembler then returns control to mini-assembler. Note that many monitor commands change current memory address reference so that it is good practice to retype desired address reference upon return to mini-assembler.
adrs:(6502 MNEMONIC instruction)	!C010:STA 23FF	Assembles a mnemonic 6502 instruction into machine codes. If error, machine will refuse instruction, sound bell, and reprint line with up arrow under error.



<u>Command Format</u>	<u>Example</u>	<u>Description</u>
(space) (6502 mnemonic instruction)	! STA 01FF	Assembles instruction into next available memory location. (Note space between "!" and instruction)
(TURN-OFF)	! (Reset Button)	Exits mini-assembler and returns to system monitor.

### Monitor Program Execution and Debugging

adrsG	*300G	Runs machine level program starting at memory (adrs).
adrsT	*800T	Traces a program starting at memory location (adrs) and continues trace until hitting a breakpoint. Break occurs on instruction 00 (BRK), and returns control to system monitor. Opens 6502 status registers (see note 1).
adrsS	*C050S	Single steps through program beginning at memory location (adrs). Type a letter S for each additional step that you want displayed. Opens 6502 status registers (see Note 1).
(Control E)	*E <sup>C</sup>	Displays 6502 status registers and opens them for modification (see Note 1).
(Control Y)	*Y <sup>C</sup>	Executes user specified machine language subroutine starting at memory location (3F8).

#### Note 1:

6502 status registers are open if they are last line displayed on screen. To change them type ":" then "data" for each register.

Example: A = 3C X = FF Y = 00 P = 32 S = F2  
 \*: FF Changes A register only  
 \*:FF 00 33 Changes A, X, and Y registers

To change S register, you must first retype data for A, X, Y and P.

### Hexidecimal Arithmetic

data1+data2	*78+34	Performs hexidecimal sum of data1 plus data2.
data1-data2	*AE-34	Performs hexidecimal difference of data1 minus data2.

<u>Command Format</u>	<u>Example</u>	<u>Description</u>
<u>Set Input/Output Ports</u>		
(X) (Control P)	*5p <sup>C</sup>	Sets printer output to I/O slot number (X). (see Note 2 below)
(X) (Control K)	*2k <sup>C</sup>	Sets keyboard input to I/O slot number (X). (see Note 2 below)

Note 2:

Only slots 1 through 7 are addressable in this mode. Address Ø (Ex: Øp<sup>C</sup> or Øk<sup>C</sup>) resets ports to internal video display and keyboard. These commands will not work unless Apple II interfaces are plugged into specified I/O slot.

Multiple Commands

*1ØØL 4ØØG AFFT	Multiple monitor commands may be given on same line if separated by a "space".
*LLLL	Single letter commands may be repeated without spaces.

## SPECIAL CONTROL AND EDITING CHARACTERS

"Control" characters are indicated by a super-scripted "C" such as G<sup>C</sup>. They are obtained by holding down the CTRL key while typing the specified letter. Control characters are NOT displayed on the TV screen. B<sup>C</sup> and C<sup>C</sup> must be followed by a carriage return. Screen editing characters are indicated by a sub-scripted "E" such as D<sub>E</sub>. They are obtained by pressing and releasing the ESC key then typing specified letter. Edit characters send information only to display screen and does not send data to memory. For example, U<sup>C</sup> moves to cursor to right and copies text while A<sub>E</sub> moves cursor to right but does not copy text.

### CHARACTER

### DESCRIPTION OF ACTION

RESET key	Immediately interrupts any program execution and resets computer. Also sets all text mode with scrolling window at maximum. Control is transferred to System Monitor and Apple prompts with a "*" (asterisk) and a bell. Hitting RESET key does NOT destroy existing BASIC or machine language program.
Control B	If in System Monitor (as indicated by a "*"), a control B and a carriage return will transfer control to BASIC, <u>scratching (killing) any existing BASIC program</u> and set HIMEM: to maximum installed user memory and LOMEM: to 2048.
Control C	If in BASIC, halts program and displays line number where stop occurred*. Program may be continued with a CON command. If in <u>System Monitor</u> , (as indicated by "*"), control C and a carriage return will enter BASIC <u>without killing current program</u> .
Control G	Sounds bell (beeps speaker)
Control H	Backspaces cursor and deletes any overwritten characters from computer but not from screen. Apply supplied keyboards have special key "+" on right side of keyboard that provides this functions without using control button.
Control J	Issues line feed only
Control V	Compliment to H <sup>C</sup> . Forward spaces cursor and copies over written characters. Apple keyboards have "+" key on right side which also performs this function.
Control X	Immediately deletes current line.

\* If BASIC program is expecting keyboard input, you will have to hit carriage return key after typing control C.

SPECIAL CONTROL AND EDITING CHARACTERS

(continued)

<u>CHARACTER</u>	<u>DESCRIPTION OF ACTION</u>
A <sub>E</sub>	Move cursor to right
B <sub>E</sub>	Move cursor to left
C <sub>E</sub>	Move cursor down
D <sub>E</sub>	Move cursor up
E <sub>E</sub>	Clear text from cursor to end of line
F <sub>E</sub>	Clear text from cursor to end of page
@ <sub>E</sub>	Home cursor to top of page, clear text to end of page.

## Special Controls and Features

<u>Hex</u>	<u>BASIC Example</u>	<u>Description</u>
<u>Display Mode Controls</u>		
C050	10 POKE -16304,0	Set color graphics mode
C051	20 POKE -16303,0	Set text mode
C052	30 POKE -16302,0	Clear mixed graphics
C053	40 POKE -16301,0	Set mixed graphics (4 lines text)
C054	50 POKE -16300,0	Clear display Page 2 (BASIC commands use Page 1 only)
C055	60 POKE -16299,0	Set display to Page 2 (alternate)
C056	70 POKE -16298,0	Clear HIRES graphics mode
C057	80 POKE -16297,0	Set HIRES graphics mode
<u>TEXT Mode Controls</u>		
0020	90 POKE 32,L1	Set left side of scrolling window to location specified by L1 in range of 0 to 39.
0021	100 POKE 33,W1	Set window width to amount specified by W1. $L1+W1 < 40$ . $W1 > 0$
0022	110 POKE 34,T1	Set window top to line specified by T1 in range of 0 to 23
0023	120 POKE 35,B1	Set window bottom to line specified by B1 in the range of 0 to 23. $B1 > T1$
0024	130 CH=PEEK(36) 140 POKE 36,CH 150 TAB(CH+1)	Read/set cursor horizontal position in the range of 0 to 39. If using TAB, you must add "1" to cursor position read value; Ex. 140 and 150 perform identical function.
0025	160 CV=PEEK(37) 170 POKE 37,CV 180 VTAB(CV+1)	Similar to above. Read/set cursor vertical position in the range 0 to 23.
0032	190 POKE 50,127 200 POKE 50,255	Set inverse flag if 127 (Ex. 190) Set normal flag if 255(Ex. 200)
FC58	210 CALL -936	(@E) Home cursor, clear screen
FC42	220 CALL -958	(FE) Clear from cursor to end of page

<u>Hex</u>	<u>BASIC Example</u>	<u>Description</u>
FC9C	23Ø CALL -868	(E <sub>F</sub> ) Clear from cursor to end of line
FC66	24Ø CALL -922	(J <sup>C</sup> ) Line feed
FC7Ø	25Ø CALL -912	Scroll up text one line

### Miscellaneous

CØ3Ø	36Ø X=PEEK(-16336) 365 POKE -16336,Ø	Toggle speaker
CØØØ	37Ø X=PEEK(-16384	Read keyboard; if X>127 then key was pressed.
CØ1Ø	38Ø POKE -16368,Ø	Clear keyboard strobe - always after reading keyboard.
CØ61	39Ø X=PEEK(16287)	Read PDL(Ø) push button switch. If X>127 then switch is "on".
CØ62	4ØØ X=PEEK(-16286)	Read PDL(1) push button switch.
CØ63	41Ø X=PEEK(-16285	Read PDL(2) push button switch.
CØ58	42Ø POKE -16296,Ø	Clear Game I/O ANØ output
CØ59	43Ø POKE -16295,Ø	Set Game I/O ANØ output
CØ5A	44Ø POKE -16294,Ø	Clear Game I/O AN1 output
CØ5B	45Ø POKE -16293,Ø	Set Game I/O AN1 output
CØ5C	46Ø POKE -16292,Ø	Clear Game I/O AN2 output
CØ5D	47Ø POKE -16291,Ø	Set Game I/O AN2 output
CØ5E	48Ø POKE -16290,Ø	Clear Game I/O AN3 output
CØ5F	49Ø POKE -16289,Ø	Set Game I/O AN3 output

```

*****
*
*      APPLE II
*      SYSTEM MONITOR
*
*      COPYRIGHT 1977 BY
*      APPLE COMPUTER, INC.
*
*      ALL RIGHTS RESERVED
*
*      S. WOZNIAK
*      A. BAUM
*
*****

```

	TITLE	"APPLE II SYSTEM MONITOR"
LOC0	EPZ	\$00
LOC1	EPZ	\$01
WNDLFT	EPZ	\$20
WNDWDTH	EPZ	\$21
WNDTOP	EPZ	\$22
WNBDM	EPZ	\$23
CH	EPZ	\$24
CV	EPZ	\$25
GBASL	EPZ	\$26
GBASH	EPZ	\$27
BASL	EPZ	\$28
BASH	EPZ	\$29
BAS2L	EPZ	\$2A
BAS2H	EPZ	\$2B
H2	EPZ	\$2C
LMNEM	EPZ	\$2C
RTNL	EPZ	\$2C
V2	EPZ	\$2D
RMNEM	EPZ	\$2D
RTNH	EPZ	\$2D
MASK	EPZ	\$2E
CHKSUM	EPZ	\$2E
FORMAT	EPZ	\$2E
LASTIN	EPZ	\$2F
LENGTH	EPZ	\$2F
SIGN	EPZ	\$2F
COLOR	EPZ	\$30
MODE	EPZ	\$31
INVFLG	EPZ	\$32
PROMPT	EPZ	\$33
YSAV	EPZ	\$34
YSAV1	EPZ	\$35
CSWL	EPZ	\$36
CSWH	EPZ	\$37
KSWL	EPZ	\$38
KSWH	EPZ	\$39
PCL	EPZ	\$3A
PCH	EPZ	\$3B
XQT	EPZ	\$3C
A1L	EPZ	\$3C
A1H	EPZ	\$3D
A2L	EPZ	\$3E
A2H	EPZ	\$3F
A3L	EPZ	\$40
A3H	EPZ	\$41
A4L	EPZ	\$42
A4H	EPZ	\$43
A5L	EPZ	\$44
A5H	EPZ	\$45

	ACC	EPZ	\$45		
	XREG	EPZ	\$46		
	YREG	EPZ	\$47		
	STATUS	EPZ	\$48		
	SPNT	EPZ	\$49		
	RNDL	EPZ	\$4F		
	RNDH	EPZ	\$4F		
	ACL	EPZ	\$50		
	ACH	EPZ	\$51		
	XTNDL	EPZ	\$52		
	XTNDH	EPZ	\$53		
	AUXL	EPZ	\$54		
	AUXH	EPZ	\$55		
	PICK	EPZ	\$95		
	IN	EOU	\$0200		
	USHADR	EOU	\$03F8		
	MMI	EOU	\$03FB		
	IFOLOC	EOU	\$03FE		
	ICADR	EQU	SC000		
	KRD	EQU	SC000		
	KRDSTRB	EQU	SC010		
	TAPEOUT	EQU	SC020		
	SPKR	EQU	SC030		
	TXICLR	EQU	SC050		
	TXTSET	EQU	SC051		
	MIXCLR	EQU	SC052		
	MIXSET	EQU	SC053		
	LOWSCR	EQU	SC054		
	HISCR	EQU	SC055		
	LORES	EQU	SC056		
	HIRES	EQU	SC057		
	TAPEIN	EQU	SC060		
	PADDL0	EQU	SC064		
	PTRIG	EQU	SC070		
	BASIC	EQU	SE000		
	BASIC2	EQU	SE003		
		ORG	\$F800	ROM START ADDRESS	
F800:	4A	PLOT	LSR	A	Y-COORD/2
F801:	08		PHP		SAVE LSB IN CARRY
F802:	20 47 F8		JSR	GBASCALC	CALC BASE ADR IN GBASL,H
F805:	28		PLP		RESTORE LSB FROM CARRY
F806:	A9 0F		LDA	#S0F	MASK S0F IF EVEN
F808:	90 02		BCC	RTMASK	
F80A:	69 E0		ADC	#SE0	MASK \$F0 IF ODD
F80C:	85 2E	RTMASK	STA	MASK	
F80E:	B1 26	PLOT1	LDA	(GBASL),Y	DATA
F810:	45 30		EOR	COLOR	XOR COLOR
F812:	25 2E		AND	MASK	AND MASK
F814:	51 26		EOR	(GBASL),Y	XOR DATA
F816:	91 26		STA	(GBASL),Y	TO DATA
F818:	60		RTS		
F819:	20 00 F8	HLINE	JSR	PLOT	PLOT SQUARE
F81C:	C4 2C	HLINE1	CPY	H2	DONE?
F81E:	B0 11		BCS	RTS1	YES, RETURN
F820:	C8		INY		NO, INCR INDEX (X-COORD)
F821:	20 0E F8		JSR	PLOT1	PLOT NEXT SQUARE
F824:	90 F6		BCC	HLINE1	ALWAYS TAKEN
F826:	69 01	VLINEZ	ADC	#S01	NEXT Y-COORD
F828:	48	VLINE	PHA		SAVE ON STACK
F829:	20 00 F8		JSR	PLOT	PLOT SQUARE
F82C:	68		PLA		
F82D:	C5 2D		CMP	V2	DONE?
F82F:	90 F5		BCC	VLINEZ	NO, LOOP.
F831:	60	RTS1	RTS		
F832:	A0 2F	CLRSCF	LDY	#S2F	MAX Y, FULL SCRN CLR
F834:	D0 02		PNE	CLRSC2	ALWAYS TAKEN
F836:	A0 27	CLRTOP	LDY	#S27	MAX Y, TOP SCRN CLR
F838:	84 2D	CLRSC2	STY	V2	STORE AS BOTTOM COORD
		*	FOR	VLINE CALLS	
F83A:	A0 27		LDY	#S27	RIGHTMOST X-COORD (COLUMN)
F83C:	A9 00	CLRSC3	LDA	#S0	TOP COORD FOR VLINE CALLS
F83E:	85 30		STA	COLOR	CLEAR COLOR (BLACK)
F840:	20 28 F8		JSR	VLINE	DRAW VLINE
F843:	88		DEY		NEXT LEFTMOST X-COORD
F844:	10 F6		BPL	CLRSC3	LOOP UNTIL DONE.
F846:	60		RTS		
F847:	48	GBASCALC	PHA		FOR INPUT 000DEFGH
F848:	4A		LSR	A	
F849:	29 03		AND	#S03	
F84B:	09 04		ORA	#S04	GENERATE GBASH=000C01FC
F84D:	85 27		STA	GBASH	
F84F:	68		PLA		AND GBASL=HDEDF000
F850:	29 18		AND	#S18	
F852:	90 02		SCC	CALC	
F854:	69 7F		ADC	#S7F	
F856:	85 26	GBASCALC	STA	GBASL	



F858:	0A		ASL	A	
F859:	0A		ASL	A	
F85A:	05 26		ORA	GBASL	
F85C:	85 26		STA	GPASL	
F85E:	60		RTS		
F85F:	A5 30	NXTCOL	LDA	COLOR	INCPERENT COLOR BY 3
F861:	18		CLC		
F862:	69 03		ADC	#S03	
F864:	29 0F	SETCOL	AND	#S0F	SEPS COLOR=17*A MOD 16
F866:	85 30		STA	COLOR	
F868:	0A		ASL	A	BOTH HALF BYTES OF COLOR EQUAL
F869:	0A		ASL	A	
F86A:	0A		ASL	A	
F86B:	0A		ASL	A	
F86C:	05 30		ORA	COLOR	
F86E:	85 30		STA	COLOR	
F870:	60		RTS		
F871:	4A	SCRN	LSR	A	READ SCPEEN Y-COORD/2
F872:	06		PHP		SAVE LSB (CARRY)
F873:	20 47 F8		JSR	GBASCALC	CALC BASE ADDRESS
F876:	B1 26		LDA	(GBASL),Y	GET BYTE
F878:	28		PLP		RESTORE LSP FROM CARRY
F879:	90 04	SCRN2	RCC	RTMSKZ	IF EVEN, USE LO H
F87B:	4A		LSR	A	
F87C:	4A		LSR	A	
F87D:	4A		LSR	A	SHIFT HIGH HALF BYTE DOWN
F87E:	4A		LSR	A	
F87F:	29 0F	RTMSKZ	AND	#S0F	MASK 4-BITS
F881:	60		RTS		
F882:	A6 3A	INSDS1	LDX	PCL	PRINT PCL,H
F884:	A4 3E		LDY	PCF	
F886:	20 96 FE		JSR	PRYX2	
F889:	20 48 F9		JSR	PRBLNK	FOLLOWED BY A BLANK
F88C:	A1 3A		LEA	(PCL,X)	GET OP CODE
F88E:	A8	INSDS2	TAY		
F88F:	4A		LSR	A	EVEN/ODD TEST
F890:	90 09		BCC	IEVEN	
F892:	6A		ROP	A	BIT 1 TEST
F893:	80 10		BCS	8FF	XXXXXXXX11 INVALID OP
F895:	C9 A2		CMF	#SA2	
F897:	F0 0C		PEO	8FF	OPCODE 889 INVALID
F899:	29 87		AND	#S87	MASK BITS
F89B:	4A	IEVEN	LSR	A	LSR INTO CARRY FOR L/P TEST
F89C:	AA		TAX		
F89D:	BC 62 F9		LDA	FMT1,X	GET FORMAT INDEX BYTE
F8A0:	20 79 F8		JSR	SCRN2	P/L H-BYTE ON CARRY
F8A3:	D0 04		RNE	GETFMT	
F8A5:	A0 80	ERP	LDY	#S8C	SUBSTITUTE S80 FOR INVALID OPS
F8A7:	A9 00		LDA	#S0	SET PRINT FOPVAT INDEX TO 0
F8A9:	AA	GETFMT	TAX		
F8AA:	BD A6 F9		LDA	FMT2,X	INDEX INTO PRINT FORMAT TABLE
F8AD:	85 2E		STA	FORMAT	SAVE FOR ADR FIELD FORMATTING
F8AF:	29 03		AND	#S03	MASK FOR 2-BIT LENGTH
		*			(P=1 BYTE, 1=2 BYTE, 2=3 BYTE)
F8B1:	85 2F		STA	LENGTH	
F8B3:	98		TYA		OPCODE
F8B4:	29 8F		AND	#S8F	MASK FOR 1XXX1010 TEST
F8B6:	AA		TAX		SAVE IT
F8B7:	98		TYA		OPCODE TO A AGAIN
F8B8:	A0 03		LDY	#S03	
F8BA:	E0 8A		CPX	#S8A	
F8BC:	F0 0B		BEQ	MNNDX3	
F8BE:	4A	MNNDX1	LSR	A	
F8BF:	90 08		BCC	MNNDX3	FORM INDEX INTO MNEMONIC TABLE
F8C1:	4A		LSR	A	
F8C2:	4A	MNNDX2	LSR	A	1) 1XXX1010=>00101XXX
F8C3:	09 20		ORA	#S20	2) XXXYYY01=>00111XXX
F8C5:	88		DEY		3) XXXYYY10=>00110XXX
F8C6:	D0 FA		BNE	MNNDX2	4) XXXYYY100=>00100XXX
F8C8:	C8		INY		5) XXXXX000=>000XXXXX
F8C9:	88	MNNDX3	DEY		
F8CA:	D0 F2		BNE	MNNDX1	
F8CC:	60		RTS		
F8CD:	FF FF FF		DFB	\$FF,\$FF,\$FF	
F8D0:	20 82 F8	INSTDSP	JSR	INSDS1	GEN FMT, LEN BYTES
F8D3:	48		PHA		SAVE MNEMONIC TABLE INDEX
F8D4:	B1 3A	PRNTOP	LDA	(PCL),Y	
F8D6:	20 DA FD		JSR	PRBYTE	
F8D9:	A2 01		LDX	#S01	PRINT 2 BLANKS
F8DB:	20 4A F9	PRNTBL	JSR	PRBL2	
F8DE:	C4 2F		CPY	LENGTH	PRINT INST (1-3 BYTES)
F8E0:	C8		INY		IN A 12 CHR FIELD
F8E1:	90 F1		BCC	PRNTOP	
F8E3:	A2 03		LDX	#S03	CHAR COUNT FOR MNEMONIC PRINT
F8E5:	C0 04		CPY	#S04	

F8E7: 90 F2		BCC	PRNTBL	
F8E9: 68		PLA		RECOVER MNEMONIC INDEX
F8EA: A8		TAY		
F8EB: B9 C0 F9		LDA	MNEML,Y	
F8EE: 85 2C		STA	LMNEM	FETCH 3-CHAR MNEMONIC
F8F0: B9 00 FA		LDA	MNEMR,Y	(PACKED IN 2-BYTES)
F8F3: 85 2D		STA	RMNEM	
F8F5: A9 00	PRMN1	LDA	#\$00	
F8F7: A0 05		LDY	#\$05	
F8F9: 06 2D	PRMN2	ASL	RMNEM	SHIFT 5 BITS OF
F8FB: 26 2C		ROL	LMNEM	CHARACTER INTO A
F8FD: 2A		ROL	A	(CLEARS CARRY)
F8FE: 88		DEY		
F8FF: D0 F8		BNE	PRMN2	
F901: 69 BF		ADC	#\$BF	ADD "?" OFFSET
F903: 20 ED FD		JSR	COUT	OUTPUT A CHAR OF MNEM
F906: CA		DEX		
F907: D0 EC		BNE	PRMN1	
F909: 20 48 F9		JSR	PRBLNK	OUTPUT 3 BLANKS
F90C: A4 2F		LDY	LENGTH	
F90E: A2 06		LDX	#\$06	CNT FOR 6 FORMAT BITS
F910: E0 03	PRADR1	CPX	#\$03	
F912: F0 1C		BEQ	PRADR5	IF X=3 THEN ADDR.
F914: 06 2E	PRADR2	ASL	FORMAT	
F916: 90 0E		BCC	PRADR3	
F918: BD B3 F9		LDA	CHAR1-1,X	
F91B: 20 ED FD		JSR	COUT	
F91E: BD B9 F9		LDA	CHAR2-1,X	
F921: F0 03		BEQ	PRADR3	
F923: 20 ED FD		JSR	COUT	
F926: CA	PRADR3	DEX		
F927: D0 E7		BNE	PRADR1	
F929: 60		RTS		
F92A: 88	PRADR4	DEY		
F92B: 30 E7		BMI	PRADR2	
F92D: 20 DA FD		JSR	PRBYTE	
F930: A5 2E	PRADR5	LDA	FORMAT	
F932: C9 E8		CMP	#\$E8	HANDLE REL ADR MODE
F934: B1 3A		LDA	(PCL),Y	SPECIAL (PRINT TARGET,
F936: 90 F2		BCC	PRADR4	NOT OFFSET)
F938: 20 56 F9	RELADR	JSR	PCADJ3	
F93B: AA		TAX		PCL,PCH+OFFSET+1 TO A,Y
F93C: E8		INX		
F93D: D0 01		BNE	PRNTYX	+1 TO Y,X
F93F: C8		INY		
F940: 98	PRNTYX	TYA		
F941: 20 DA FD	PRNTAX	JSR	PRBYTE	OUTPUT TARGET ADR
F944: 8A	PRNTAX	TXA		OF BRANCH AND RETURN
F945: 4C DA FD		JMP	PRBYTE	
F948: A2 03	PRBLNK	LDX	#\$03	BLANK COUNT
F94A: A9 A0	PRBL2	LDA	#\$A0	LOAD A SPACE
F94C: 20 ED FD	PRBL3	JSR	COUT	OUTPUT A BLANK
F94F: CA		DEX		
F950: D0 F8		BNE	PRBL2	LOOP UNTIL COUNT=0
F952: 60		RTS		
F953: 38	PCADJ	SEC		0=1-BYTE,1=2-BYTE,
F954: A5 2F	PCADJ2	LDA	LENGTH	2=3-BYTE
F956: A4 3B	PCADJ3	LDY	PCH	
F958: AA		TAX		TEST DISPLACEMENT SIGN
F959: 10 01		BPL	PCADJ4	(FOR REL BRANCH)
F95B: 88		DEY		EXTEND NEG BY DECR PCH
F95C: 65 3A	PCADJ4	ADC	PCL	
F95E: 90 01		BCC	RTS2	PCL+LENGTH(OR DISPL)+1 TO A
F960: C8		INY		CARRY INTO Y (PCH)
F961: 60	RTS2	RTS		
*		FMT1	BYTES:	XXXXXXXXY0 INSTRS
*			IF Y=0	THEN LEFT HALF BYTE
*			IF Y=1	THEN RIGHT HALF BYTE
*				(X=INDEX)
F962: 04 20 54		DFB	\$04,\$20,\$54,\$30,\$0D	
F965: 30 0D	FMT1			
F967: 80 04 90		DFB	\$80,\$04,\$90,\$03,\$22	
F96A: 03 22				
F96C: 54 33 0D		DFB	\$54,\$33,\$0D,\$80,\$04	
F96F: 80 04				
F971: 90 04 20		DFB	\$90,\$04,\$20,\$54,\$33	
F974: 54 33				
F976: 0D 80 04		DFB	\$0D,\$80,\$04,\$90,\$04	
F979: 90 04				
F97B: 20 54 3B		DFB	\$20,\$54,\$3B,\$0D,\$80	
F97E: 0D 80				
F980: 04 90 00		DFB	\$04,\$90,\$00,\$22,\$44	
F983: 22 44				
F985: 33 0D C8		DFB	\$33,\$0D,\$C8,\$44,\$00	
F988: 44 00				

F98A:	11 22 44				
F98D:	33 0D		DFB	\$11,\$22,\$44,\$33,\$0D	
F98F:	C8 44 A9				
F992:	01 22		DFB	SC8,\$44,\$A9,\$01,\$22	
F994:	44 33 0D				
F997:	80 04		DFB	\$44,\$33,\$0D,\$80,\$04	
F999:	90 01 22				
F99C:	44 33		DFB	\$90,\$01,\$22,\$44,\$33	
F99E:	0D 80 04				
F9A1:	90		DFB	\$0D,\$80,\$04,\$90	
F9A2:	26 31 87				
F9A5:	9A		DFB	\$26,\$31,\$27,\$9A ZZXXXY01 INSTR'S	
F9A6:	00	FMT2	DFB	\$00 ERR	
F9A7:	21		DFB	\$21 IMM	
F9A8:	81		DFB	\$81 Z-PAGE	
F9A9:	82		DFB	\$82 ABS	
F9AA:	00		DFB	\$00 IMPLIED	
F9AB:	00		DFB	\$00 ACCUMULATOR	
F9AC:	59		DFB	\$59 (ZPAG,X)	
F9AD:	4D		DFB	\$4D (ZPAG),Y	
F9AE:	91		DFB	\$91 ZPAG,X	
F9AF:	92		DFB	\$92 ABS,X	
F9B0:	86		DFB	\$86 ABS,Y	
F9B1:	4A		DFB	\$4A (ABS)	
F9B2:	85		DFB	\$85 ZPAG,Y	
F9B3:	9D		DFB	\$9D RELATIVE	
F9B4:	AC A9 AC				
	A3 A8 A4				
		CHAR1	ASC	" , ) , # ( \$"	
F9BA:	D9 00 D8				
F9BD:	A4 A4 00	CHAR2	DFB	\$D9,\$00,\$D8,\$A4,\$A4,\$00	
		*CHAR2:		"Y",0,"XSS",0	
		*	MNEML	IS OF FORM:	
		*	(A)	XXXXXX000	
		*	(B)	XXXXYY100	
		*	(C)	1XXX1010	
		*	(D)	XXXXYYY10	
		*	(E)	XXXXYYY01	
		*	(X=INDEX)		
F9C0:	1C 8A 1C				
F9C3:	23 5D 8B	MNEML	DFB	\$1C,\$8A,\$1C,\$23,\$5D,\$8B	
F9C6:	1B A1 9D				
F9C9:	8A 1D 23		DFB	\$1B,\$A1,\$9D,\$8A,\$1D,\$23	
F9CC:	9D 8B 1D				
F9CF:	A1 00 29		DFB	\$9D,\$8B,\$1D,\$A1,\$00,\$29	
F9D2:	19 AE 69				
F9D5:	A8 19 23		DFB	\$19,\$AE,\$69,\$A8,\$19,\$23	
F9D8:	24 53 1B				
F9DB:	23 24 53		DFB	\$24,\$53,\$1B,\$23,\$24,\$53	
F9DE:	19 A1		DFB	\$19,\$A1 (A) FORMAT ABOVE	
F9E0:	00 1A 5B				
F9E3:	5B A5 69		DFB	\$00,\$1A,\$5B,\$5B,\$A5,\$69	
F9E6:	24 24		DFB	\$24,\$24 (B) FORMAT	
F9E8:	AE AE A8				
F9EB:	AD 29 00		DFB	\$AE,\$AE,\$A8,\$AD,\$29,\$00	
F9EE:	7C 00		DFB	\$7C,\$00 (C) FORMAT	
F9F0:	15 9C 6D				
F9F3:	9C A5 69		DFB	\$15,\$9C,\$6D,\$9C,\$A5,\$69	
F9F6:	29 53		DFB	\$29,\$53 (D) FORMAT	
F9F8:	84 13 34				
F9FB:	11 A5 69		DFB	\$84,\$13,\$34,\$11,\$A5,\$69	
F9FE:	23 A0		DFB	\$23,\$A0 (E) FORMAT	
FA00:	D8 62 5A				
FA03:	48 26 62	MNEMR	DFB	\$D8,\$62,\$5A,\$48,\$26,\$62	
FA06:	94 88 54				
FA09:	44 C8 54		DFB	\$94,\$88,\$54,\$44,\$C8,\$54	
FA0C:	68 44 E8				
FA0F:	94 00 B4		DFB	\$68,\$44,\$E8,\$94,\$00,\$B4	
FA12:	08 84 74				
FA15:	B4 28 6E		DFB	\$08,\$84,\$74,\$B4,\$28,\$6E	
FA18:	74 F4 CC				
FA1B:	4A 72 F2		DFB	\$74,\$F4,\$CC,\$4A,\$72,\$F2	
FA1E:	A4 8A		DFB	\$A4,\$8A (A) FORMAT	
FA20:	00 AA A2				
FA23:	A2 74 74		DFB	\$00,\$AA,\$A2,\$A2,\$74,\$74	
FA26:	74 72		DFB	\$74,\$72 (B) FORMAT	
FA28:	44 68 82				
FA2B:	32 B2 00		DFB	\$44,\$68,\$B2,\$32,\$B2,\$00	
FA2E:	22 00		DFB	\$22,\$00 (C) FORMAT	
FA30:	1A 1A 26				
FA33:	26 72 72		DFB	\$1A,\$1A,\$26,\$26,\$72,\$72	
FA36:	88 C8		DFB	\$88,\$C8 (D) FORMAT	
FA38:	C4 CA 26				
FA3B:	48 44 44		DFB	SC4,\$CA,\$26,\$4E,\$44,\$44	
FA3E:	A2 C8		DFB	SA2,\$C8 (E) FORMAT	

FA40:	FF	FF	FF		DFB	SFF,SFF,\$FF	
FA43:	20	D0	F8	STEP	JSR	INSTDSP	DISASSEMBLE ONE INST
FA46:	68				PLA		AT (PCL,H)
FA47:	85	2C			STA	RTNL	ADJUST TO USER
FA49:	68				PLA		STACK. SAVE
FA4A:	85	2D			STA	RTNH	RTM ADR.
FA4C:	A2	08			LDX	#\$08	
FA4E:	BD	10	FB	XQINIT	LDA	INIT8L-1,X	INIT XEO AREA
FA51:	95	3C			STA	XQT,X	
FA53:	CA				DEX		
FA54:	D0	F8			BNE	XQINIT	
FA56:	A1	3A			LDA	(PCL,X)	USER OPCODE BYTE
FA58:	F0	42			BEO	XBRK	SPECIAL IF BRFK
FA5A:	A4	2F			LDY	LENGTH	LEN FROM DISASSEMBLY
FA5C:	C9	20			CMP	#\$20	
FA5E:	F0	59			BEO	XJSR	HANDLE JSR, PTS, JMP,
FA60:	C9	60			CMP	#\$60	JMP ( ), RTI SPECIAL
FA62:	F0	45			BEQ	XRTS	
FA64:	C9	4C			CMP	#\$4C	
FA66:	F0	5C			BEQ	XJMP	
FA68:	C9	6C			CMP	#\$6C	
FA6A:	F0	59			BEQ	XJMFAT	
FA6C:	C9	40			CMP	#\$40	
FA6E:	F0	35			BEQ	XRTI	
FA70:	29	1F			AND	#\$1F	
FA72:	49	14			EOR	#\$14	
FA74:	C9	04			CMP	#\$04	COPY USER INST TO XEO AREA
FA76:	F0	02			BEQ	XQ2	WITH TRAILING NOPS
FA78:	B1	3A		XQ1	LDA	(PCL),Y	CHANGE REL BRANCH
FA7A:	99	3C	00	XQ2	STA	XQTNZ,Y	DISP TO 4 FOR
FA7D:	88				DEY		JMP TO BRANCH OR
FA7E:	10	F8			BPL	XQ1	NBRANCH FROM XEQ.
FA80:	20	3F	FF		JSR	RESTORE	RESTORE USER REG CONTENTS.
FA83:	4C	3C	00		JMP	XQTNZ	XEQ USER OP FROM RAM
FA86:	85	45		IRQ	STA	ACC	(RETURN TO NBRANCH)
FA88:	68				PLA		
FA89:	48				PHA		**IRQ HANDLER
FA8A:	0A				ASL	A	
FA8B:	0A				ASL	A	
FA8C:	0A				ASL	A	
FA8D:	30	03			BMI	BREAK	TEST FOR BREAK
FA8F:	6C	FE	03		JMP	(IROLOC)	USER ROUTINE VECTOR IN RAM
FA92:	28			BREAK	PLP		
FA93:	20	4C	FF		JSR	SAV1	SAVE REG'S ON BREAK
FA96:	68				PLA		INCLUDING PC
FA97:	85	3A			STA	PCL	
FA99:	68				PLA		
FA9A:	85	3B			STA	PCH	
FA9C:	20	82	F8	XBRK	JSR	INSDS1	PRINT USER PC.
FA9F:	20	DA	FA		JSR	RGDSP1	AND REG'S
FAA2:	4C	65	FF		JMP	MON	GO TO MONITOR
FAA5:	18			XRTI	CLC		
FAA6:	68				PLA		SIMULATE RTI BY EXPECTING
FAA7:	85	48			STA	STATUS	STATUS FROM STACK, THEN RTS
FAA9:	68			XRTS	PLA		RTS SIMULATION
FAAA:	85	3A			STA	PCL	EXTRACT PC FROM STACK
FAAC:	68				PLA		AND UPDATE PC BY 1 (LEN=0)
FAAD:	85	3B		PCINC2	STA	PCH	
FAAF:	A5	2F		PCINC3	LDA	LENGTH	UPDATE PC BY LEN
FAB1:	20	56	F9		JSR	PCADJ3	
FAB4:	84	3B			STY	PCH	
FAB6:	18				CLC		
FAB7:	90	14			BCC	NEWPCL	
FAB9:	18			XJSR	CLC		
FABA:	20	54	F9		JSR	PCADJ2	UPDATE PC AND PUSH
FABD:	AA				TAX		ONTO STACK FOR
FABE:	98				TYA		JSR SIMULATE
FABF:	48				PHA		
FAC0:	8A				TXA		
FAC1:	48				PHA		
FAC2:	A0	02			LDY	#\$02	
FAC4:	18			XJMP	CLC		
FAC5:	B1	3A		XJMPAT	LDA	(PCL),Y	
FAC7:	AA				TAX		LOAD PC FOR JMP,
FAC8:	88				DEY		(JMP) SIMULATE.
FAC9:	B1	3A			LDA	(PCL),Y	
FACB:	86	3B			STX	PCH	
FACD:	85	3A		NEWPCL	STA	PCL	
FACF:	B0	F3			BCS	XJMP	
FAD1:	A5	2D		RTNJMP	LDA	RTNH	
FAD3:	48				PHA		
FAD4:	A5	2C			LDA	RTNL	
FAD6:	48				PHA		
FAD7:	20	8E	FD	REGDSP	JSR	CROUT	DISPLAY USER REG
FADA:	A9	45		RGDSP1	LDA	#ACC	CONTENTS WITH
FADC:	85	40			STA	A3L	LABELS

FADE:	A9 00		LDA	#ACC/256	
FAE0:	85 41		STA	A3H	
FAE2:	A2 FB		LDX	#\$FB	
FAE4:	A9 A0	RDSP1	LDA	#\$A0	
FAE6:	20 ED FD		JSR	COUT	
FAE9:	BD 1E FA		LDA	RTBL-\$FB,X	
FAEC:	20 ED FD		JSR	COUT	
FAEF:	A9 BD		LDA	#\$8D	
FAF1:	20 ED FD		JSR	COUT	
FAF4:	B5 4A		LDA	ACC+5,X	
FAF6:	20 DA FD		JSR	PRBYTE	
FAF9:	E8		INX		
FAFA:	30 E8		BMI	RDSP1	
FAFC:	60		RTS		
FAFD:	18	BRANCH	CLC		BRANCH TAKEN,
FAFE:	A0 01		LDY	#\$01	ADD LEN+2 TO PC
FB00:	B1 3A		LDA	(PCL),Y	
FB02:	20 56 F9		JSR	PCADJ3	
FB05:	85 3A		STA	PCL	
FB07:	98		TYA		
FB08:	38		SEC		
FB09:	B0 A2		BCS	PCINC2	
FB0B:	20 4A FF	NBRNCH	JSR	SAVE	NORMAL RETURN AFTER
FB0E:	38		SEC		XEQ USER OF
FB0F:	B0 9E		RCS	PCINC3	GO UPDATE PC
FB11:	EA	INITBL	NOP		
FB12:	EA		NOP		DUMMY FILL FOR
FB13:	4C 0B FB		JMP	NBRNCH	XEQ AREA
FB16:	4C FD FA		JMP	BRANCH	
FB19:	C1	RTBL	DFB	SC1	
FB1A:	D8		DFB	\$D8	
FB1B:	D9		DFB	\$D9	
FB1C:	D0		DFB	\$D0	
FB1D:	D3		DFB	\$D3	
FB1E:	AD 70 C0	PREAD	LDA	PTPIG	TRIGGER PADDLES
FB21:	A0 00		LDY	#\$00	INIT COUNT
FB23:	EA		NOP		COMPENSATE FOR 1ST COUNT
FB24:	EA		NOP		
FB25:	BD 64 C0	PREAD2	LDA	PADDL0,X	COUNT Y-REG EVERY
FB28:	10 04		BPL	RTS2D	12 USEC
FB2A:	C8		INY		
FB2B:	D0 F8		BNE	PREAD2	EXIT AT 255 MAX
FB2D:	88		DEY		
FB2E:	60	RTS2D	RTS		
FB2F:	A9 00	INIT	LDA	#\$00	CLR STATUS FOR DEBUG
FB31:	85 48		STA	STATUS	SOFTWARE
FB33:	AD 56 C0		LDA	LORES	
FB36:	AD 54 C0		LDA	LOWSCR	INIT VIDEO MODE
FB39:	AD 51 C0	SETTXT	LDA	TXTSET	SET FOR TEXT MODE
FB3C:	A9 00		LDA	#\$00	FULL SCREEN WINDOW
FB3E:	F0 0B		REQ	SETWND	
FB40:	AD 50 C0	SETGR	LDA	TXTCLR	SET FOR GRAPHICS MODE
FB43:	AD 53 C0		LDA	MIXSET	LOWER 4 LINES AS
FB46:	20 36 F8		JSR	CLPTOP	TEXT WINDOW
FB49:	A9 14		LDA	#\$14	
FB4B:	85 22	SETWND	STA	WNDTOP	SET FOR 40 COL WINDOW
FB4D:	A9 00		LDA	#\$00	TOP IN A-REG,
FB4F:	85 20		STA	WNDLFT	BTTM AT LINE 24
FB51:	A9 28		LDA	#\$28	
FB53:	85 21		STA	WNDWETH	
FB55:	A9 18		LDA	#\$18	
FB57:	85 23		STA	WNBRTM	VTAB TO ROW 23
FB59:	A9 17		LDA	#\$17	
FB5B:	85 25	TABV	STA	CV	VTABS TO ROW IN A-REG
FB5D:	4C 22 FC		JMP	VTAB	
FB60:	20 A4 FF	MULPM	JSR	MD1	ABS VAL OF AC AUX
FB63:	A0 10	MUL	LDY	#\$10	INDEX FOR 16 BITS
FB65:	A5 50	MUL2	LDA	ACL	ACX * AUX + XTND
FB67:	4A		LSR	A	TO AC, XTND
FB68:	90 0C		BCC	MUL4	IF NO CARRY,
FB6A:	18		CLC		NO PARTIAL PROD.
FB6B:	A2 FE		LDX	#\$FE	
FB6D:	B5 54	MUL3	LDA	XTNDL+2,X	ADD MPLCND (AUX)
FB6F:	75 56		ADC	AUXL+2,X	TO PARTIAL PROD
FB71:	95 54		STA	XTNDL+2,X	(XTND).
FB73:	E8		INX		
FB74:	D0 F7		BNE	*MUL3	
FB76:	A2 03	MUL4	LDX	#\$03	
FB78:	76	MUL5	DFB	#\$76	
FB79:	50		DFB	#\$50	
FB7A:	CA		DEX		
FB7B:	10 FE		BPL	MUL5	
FB7D:	88		DEY		
FB7E:	D0 E5		BNE	MUL2	
FB80:	60		RTS		

FB81:	20 A4	FB	DIVPM	JSR	MD1	ARS VAL OF AC, AUX.
FB84:	A0 10		DIV	LDY	#S10	INDEX FOR 16 BITS
FB86:	06 50		DIV2	ASL	ACL	
FB88:	26 51			ROL	ACH	
FB8A:	26 52			RCL	XTNDL	YTND/AUX
FB8C:	26 53			ROL	XTNDH	TO AC.
FB8E:	38			SEC		
FB8F:	A5 52			LDA	XTNDL	
FB91:	F5 54			SEC	AUXL	MOD TO XTND.
FB93:	AA			TAX		
FB94:	A5 53			LDA	XTNDH	
FB96:	E5 55			SEC	AUXH	
FB98:	90 06			BCC	DIV3	
FB9A:	86 52			STX	XTNDL	
FB9C:	85 53			STA	XTNDH	
FB9E:	E6 50			INC	ACL	
FBA0:	88		DIV3	DFY		
FBA1:	D0 E3			BNE	DIV2	
FBA3:	60			RTS		
FBA4:	A0 00		MD1	LDY	#S00	FBS VAL OF AC, AUX
FBA6:	84 2F			STY	SIGN	WITH RESULT SIGN
FBA8:	A2 54			LDX	#AUXL	IN LSB OF SIGN.
FBA:	20 AF	FB		JSR	MD2	
FBAD:	A2 50			LDX	#ACL	
FBAF:	B5 01		MD2	LDA	LOC1,X	X SPECIFIES AC OR AUX
FBB1:	10 0D			BPL	MDRTS	
FBB3:	38			SEC		
FBB4:	98		MD3	TYA		
FBB5:	F5 00			SBC	LOC0,X	COMPL SPECIFIED REG
FBB7:	95 00			STA	LOC0,X	IF NEG.
FBB9:	98			TYA		
FBBA:	F5 01			SBC	LOC1,X	
FBBC:	95 01			STA	LOC1,X	
FBBE:	E6 2F			INC	SIGN	
FBC0:	60		MDRTS	RTS		
FBC1:	48		BASCALC	PHA		CALC BASE ADR IN BASL,H
FBC2:	4A			LSR	A	FOR GIVEN LINE NO.
FBC3:	29 03			AND	#S03	0<=LINE NO.<=S17
FBC5:	09 04			ORA	#S04	APG=000ABCDE, GENERATE
FBC7:	85 29			STA	BASH	BASH=000001CD
FBC9:	68			PLA		AND
FBCA:	29 18			AND	#S18	PASL=EABAB000
FBC:	90 02			BCC	BSCLC2	
FBCE:	69 7F			ADC	#S7F	
FBD0:	85 28		BSCLC2	STA	BASL	
FBD2:	0A			ASL	A	
FBD3:	0A			ASL	A	
FBD4:	05 28			ORA	BASL	
FBD6:	85 28			STA	BASL	
FBD8:	60			RTS		
FBD9:	C9 87		BELL1	CMP	#S87	BELL CHAR? (CNTRL-G)
FBDB:	D0 12			BNE	RTS2E	NO,RETURN
FBDD:	A9 40			LDA	#S40	DELAY .01 SECONDS
FBDF:	20 A8	FC		JSR	WAIT	
FBE2:	A0 C0			LDY	#SC0	
FBE4:	A9 0C		BELL2	LDA	#S0C	TOGGLE SPEAKER AT
FBE6:	20 A8	FC		JSR	WAIT	1 KHZ FOR .1 SEC.
FBE9:	AD 30	CO		LDA	SPKR	
FBE:	88			DEY		
FBED:	D0 F5			BNE	BELL2	
FBEF:	60		RTS2E	RTS		
FBF0:	A4 24		STOADV	LDY	CH	CURSER H INDEX TO Y-REG
FBF2:	91 28			STA	(BASL),Y	STOR CHAR IN LINE
FBF4:	E6 24		ADVANCE	INC	CH	INCREMENT CURSER H INDEX
FBF6:	A5 24			LDA	CH	(MOVE RIGHT)
FBF8:	C5 21			CMP	WNDWDTH	BEYOND WINDOW WIDTH?
FBFA:	B0 66			BCS	CR	YES "P TO NFXST LINE
FBFC:	60		RTS3	RTS		NO,RETURN
FBFD:	C9 A0		VIDOUT	CMP	#SA0	CONTROL CHAR?
FBFF:	B0 EF			BCS	STOADV	NO,OUTPUT IT.
FC01:	A8			TAY		INVERSE VIDEO?
FC02:	10 EC			BPL	STOADV	YES, OUTPUT IT.
FC04:	C9 8D			CMP	#S8D	CR?
FC06:	F0 5A			BEQ	CR	YES.
FC08:	C9 8A			CMP	#S8A	LINE FEED?
FC0A:	F0 5A			BEQ	LF	IF SO, DO IT.
FC0C:	C9 88			CMP	#S88	BACK SPACE? (CNTRL-H)
FC0E:	D0 C9			BNE	BELL1	NO, CHECK FOR BELL.
FC10:	C6 24		BS	DEC	CH	DECREMENT CURSER H INDEX
FC12:	10 E8			BPL	RTS3	IF POS, OK. ELSE MOVE UP
FC14:	A5 21			LDA	WNDWDTH	SET CH TO WNDWDTH-1
FC16:	85 24			STA	CH	
FC18:	C6 24			DEC	CH	(RIGHTMOST SCREEN POS)
FC1A:	A5 22		UP	LDA	WNDTOP	CURSER V INDEX
FC1C:	C5 25			CMP	CV	

FC1E:	B0	OB		BCS	RTS4	IF TOP LINE THEN RETURN
FC20:	C6	25		DEC	CV	DECR CURSER V-INDEX
FC22:	A5	25		LDA	CV	GET CURSER V-INDEX
FC24:	20	C1	FB	JSR	PASCALC	GENERATE BASE ADDR
FC27:	65	20		ADC	WNDLFT	ADD WINDOW LEFT INDEX
FC29:	85	28		STA	BASL	TO BASL
FC2B:	60			PTS		
FC2C:	49	C0		EOR	#\$C0	ESC?
FC2E:	F0	28		RFO	HOME	IF SO, DO HOME AND CLEAR
FC30:	69	FD		ADC	#\$FD	ESC-A OR B CHECK
FC32:	90	C0		BCC	ADVANCE	A, ADVANCE
FC34:	F0	DA		BEO	BS	B, BACKSPACE
FC36:	69	FD		ADC	#\$FD	ESC-C OR D CHECK
FC38:	90	2C		BCC	LF	C,DOWN
FC3A:	F0	DE		BEQ	UP	D, GO UP
FC3C:	69	FD		ADC	#\$FD	ESC-E OF F CHECK
FC3E:	90	5C		BCC	CLREOL	E, CLEAR TO END OF LINE
FC40:	D0	E9		BNE	RTS4	NOT F, RETURN
FC42:	A4	24		LDY	CH	CURSOR H TO Y INDEX
FC44:	A5	25		LDA	CV	CURSOR V TO A-REGISTER
FC46:	48			PHA		SAVE CURRENT LINE ON STK
FC47:	20	24	FC	JSR	VTABZ	CALC BASE ADDRESS
FC4A:	20	9E	FC	JSR	CLEOLZ	CLEAR TO FOL, SET CARRY
FC4D:	A0	00		LDY	#\$00	CLEAR FROM H INDEX=0 FOR PEST
FC4F:	68			PLA		INCREMENT CURRENT LINE
FC50:	69	00		ADC	#\$00	(CARRY IS SET)
FC52:	C5	23		CMP	WNBDM	DONE TO BOTTOM OF WINDOW?
FC54:	90	F0		BCC	CLEOP1	NO, KEEP CLEARING LINES
FC56:	B0	CA		BCC	VTAB	YES, TAB TO CURRENT LINE
FC58:	A5	22		LDA	WNDTOP	INIT CURSOR V
FC5A:	85	25		STA	CV	AND H-INDICES
FC5C:	A0	00		LDY	#\$00	
FC5E:	84	24		STY	CH	THEN CLEAR TO END OF PAGE
FC60:	F0	E4		BEO	CLEOP1	
FC62:	A9	00		LDA	#\$00	CURSOR TO LEFT OF INDEX
FC64:	85	24		STA	CH	(PET CURSOR H=0)
FC66:	E6	25		INC	CV	INCR CURSOR V(DOWN 1 LINE)
FC68:	A5	25		LDA	CV	
FC6A:	C5	23		CMP	WNBDM	OFF SCREEN?
FC6C:	90	B6		BCC	VTABZ	NO, SET BASE ADDR
FC6E:	C6	25		DEC	CV	DECR CURSOR V(BACK TO BOTTOM LINE)
FC70:	A5	22		LDA	WNDTOP	START AT TOP OF SCRL WNDW
FC72:	48			PHA		
FC73:	20	24	FC	JSR	VTABZ	GENERATE BASE ADDRESS
FC76:	A5	28		LDA	BASL	COPY BASL,H
FC78:	85	2A		STA	BAS2L	TO BAS2L,H
FC7A:	A5	29		LDA	BASH	
FC7C:	85	2B		STA	BAS2H	
FC7E:	A4	21		LDY	WNDWTH	INIT Y TO RIGHTMOST INDEX
FC80:	88			DEY		OF SCROLLING WINDOW
FC81:	68			PLA		
FC82:	69	01		ADC	#\$01	INCR LINE NUMBRER
FC84:	C5	23		CMP	WNBDM	DONE?
FC86:	B0	0D		BCS	SCRL3	YES, FINISH
FC88:	48			PHA		
FC89:	20	24	FC	JSR	VTABZ	FORM BASL,H (BASE ADDR)
FC8C:	B1	28		LDA	(BASL),Y	MOVE A CHR UP ON LINE
FC8E:	91	2A		STA	(BAS2L),Y	
FC90:	88			DEY		NEXT CHAP OF LINE
FC91:	10	F9		BPL	SCRL2	
FC93:	30	E1		BMI	SCRL1	NEXT LINE
FC95:	A0	00		LDY	#\$00	CLEAR BOTTOM LINE
FC97:	20	9E	FC	JSR	CLEOLZ	GET BASE ADDR FOR BOTTOM LINE
FC9A:	B0	86		BCS	VTAB	CARRY IS SET
FC9C:	A4	24		LDY	CH	CURSOR H INDEX
FC9E:	A9	A0		LDA	#\$A0	
FCA0:	91	28		STA	(BASL),Y	STORE BLANKS FROM 'HERE'
FCA2:	C8			INY		TO END OF LINES (WNDWTH)
FCA3:	C4	21		CPY	WNDWTH	
FCA5:	90	F9		BCC	CLEOL2	
FCA7:	60			RTS		
FCA8:	38			SEC		
FCA9:	48			PHA		
FCAA:	E9	01		SBC	#\$01	
FCAC:	D0	FC		BNE	WAIT3	1.0204 USEC
FCAE:	68			PLA		(13+2712*A+512*A*A)
FCAF:	E9	01		SBC	#\$01	
FCB1:	D0	F6		BNE	WAIT2	
FCB3:	60			RTS		
FCB4:	E6	42		INC	A4L	INCR 2-BYTE A4
FCB6:	D0	02		BNE	NXTA1	AND A1
FCB8:	E6	43		INC	A4H	
FCBA:	A5	3C		LDA	A1L	INCP 2-BYTE A1.
FCBC:	C5	3E		CMP	A2L	
FCBE:	A5	3D		LDA	A1H	AND COMPARE TO A2

```

FCC0: E5 3F          SEC A2H
FCC2: E6 3C          INC ALL          (CARRY SET IF >=)
FCC4: D0 02          BNE RTS4R
FCC6: E6 3D          INC ALH
FCC8: 60             RTS4R
                HEADR LDY #S4R      WRITE A*256 'LONG 1'
FCC9: A0 48          HEADR LDY #S4R      HALF CYCLES
FCCB: 20 DB FC          JSP ZERDLY      (650 USEC EACH )
FCCD: D0 F9          BNE HEADR
FCDD: 69 FE          ADC #SFF
FCD2: E0 F5          PCS HEADR      THEN A 'SHORT 0'
FCD4: A0 21          LDY #S21      (400 USEC)
FCD6: 20 DB FC WRBIT JSR ZERDLY      WRITE TWO HALF CYCLES
FCD9: C8             INY          OF 250 USEC ('0')
FCDA: C8             INY          OR 500 USEC ('0')
FCDB: 88             ZERDLY
                DEY
FCDC: D0 FD          BNE ZERDLY
FCDE: 90 05          RCC WRTAPE      Y IS COUNT FOR
FCE0: A0 32          LDY #S32      TIMING LOOP
FCE2: 88             ONEDLY
                DEY
FCE3: D0 FD          BNE ONEDLY
FCE5: AC 20 CO WRTAPE LDY TAPEOUT
FCE8: A0 2C          LDY #S2C
FCEA: CA            DEX
FCEB: 60            RTS
FCEC: A2 08          RDRYTE
FCEE: 48             RDRYTE2
FCEF: 20 FA FC          JSP RD2BIT
FCF2: 68             PLA
FCF3: 2A            ROL A          NEXT BIT
FCF4: A0 3A          LDY #S3A      COUNT FOR SAMPLES
FCF6: CA            DEX
FCF7: D0 F5          BNE RDRYTE2
FCF9: 60            RTS
FCFA: 20 FD FC RD2BIT JSR RD2BIT
FCFB: 88             RDRYTE2
                DEY          DECR Y UNTIL
FCFE: AD 60 CO          LDA TAPEIN      TAPE TRANSITION
FD01: 45 2F          EOR LASTIN
FD03: 10 F8          RPL RDBIT
FD05: 45 2F          EOR LASTIN
FD07: 85 2F          STA LASTIN
FD09: C0 80          CPY #S80      SET CARRY ON Y-REG.
FD0B: 60            FTS
FD0C: A4 24          RDKEY
                LDY CH
FD0E: B1 28          LDA (BASL),Y  SET SCREEN TO FLASH
FD10: 48             PHA
FD11: 29 3F          AND #S3F
FD13: 09 40          ORA #S40
FD15: 91 28          STA (BASL),Y
FD17: 68             PLA
FD18: 6C 38 00          JMP (KSWL)     GO TO USER KEY-IN
FD1B: E6 4E          KEYIN
                INC RNDL
FD1D: D0 02          BNE KEYIN2    INCR RND NUMBER
FD1F: E6 4F          INC RNDH
FD21: 2C 00 CO KEYIN2 BIT KBD      KEY DOWN?
FD24: 10 F5          BPL KEYIN     LOOP
FD26: 91 28          STA (BASL),Y  REPLACE FLASHING SCREEN
FD28: AD 00 CO          LDA KBD      GET KEYCODE
FD2B: 2C 10 CO          BIT KBDSTPB  CLR KEY STROBE
FD2E: 60            RTS
FD2F: 20 0C FD ESC     JSR PDKEY     GET KEYCODE
FD32: 20 2C FC          JSR ESC1     HANDLE ESC FUNC.
FD35: 20 0C FD RDCHAR JSR RDKEY     READ KEY
FD38: C9 9B          CMP #S9B     ESC?
FD3A: F0 F3          BEQ ESC      YES, DON'T RETURN
FD3C: 60            RTS
FD3D: A5 32          NOTCR
                LDA INVFLG
FD3F: 48             PHA
FD40: A9 FF          LDA #SFF
FD42: 85 32          STA INVFLG    ECHO USER LINE
FD44: BD 00 02          LDA IN,X     NON INVERSE
FD47: 20 ED FD          JSR COUT
FD4A: 68             PLA
FD4B: 85 32          STA INVFLG
FD4D: BD 00 02          LDA IN,X
FD50: C9 88          CMP #S88     CHECK FOR EDIT KEYS
FD52: F0 1D          BEQ BCKSPC   BS, CTRL-X.
FD54: C9 98          CMP #S98
FD56: F0 0A          BEQ CANCEL
FD58: E0 F8          CPX #SF8     MARGIN?
FD5A: 90 03          RCC NOTCR1
FD5C: 20 3A FF          JSR BELL     YES, SOUND BELL
FD5F: E8             NOTCR1
                INX          ADVANCE INPUT INDEX
FD60: D0 13          BNE NXTCHAR
FD62: A9 DC          CANCEL
                LDA #SDC    BACKSLASH AFTER CANCELLED LINE
FD64: 20 ED FD          JSR COUT

```



FD67:	20 8E	FD	GETLNZ	JSR	CROUT	OUTPUT CR
FD6A:	A5 33		GETLN	LDA	PROMPT	
FD6C:	20 ED	FD		JSR	COUT	OUTPUT PROMPT CHAP
FD6F:	A2 01			LDX	#S01	INIT INPUT INDEX
FD71:	8A		RCKSPC	TXA		WILL BACKSPACE TO 0
FD72:	F0 F3			BEQ	GETLNZ	
FD74:	CA			DEX		
FD75:	20 35	FD	NXTCJAF	JSR	PDCHAR	
FD78:	C9 95			CMP	#PICK	USE SCREEN CHAP
FD7A:	D0 02			BNE	CAPTST	FOR CTRL-U
FD7C:	B1 28			LDA	(BASL),Y	
FD7E:	C9 E0		CAPTST	CMP	#SE0	
FD80:	90 02			BCC	ADDINP	CONVERT TO CAPS
FD82:	29 DF			AND	#SDF	
FD84:	9D 00	02	ADDINP	STA	IN,X	ADD TO INPUT BUF
FD87:	C9 8D			CMP	#S8D	
FD89:	D0 B2			BNE	NOTCR	
FD8B:	20 9C	FC		JSR	CLREOL	CLR TO EOL IF CR
FD8E:	A9 8D		CROUT	LDA	#S8D	
FD90:	D0 5B			BNE	COUT	
FD92:	A4 3D		PRAI	LDY	A1H	PRINT CR,A1 IN HEX
FD94:	A6 3C			LDX	A1L	
FD96:	20 8E	FD	PRYX2	JSR	CROUT	
FD99:	20 40	F9		JSR	PRNTYX	
FD9C:	A0 00			LDY	#S00	
FD9E:	A9 AD			LDA	#SAD	PRINT '-'
FDA0:	4C ED	FD		JMP	COUT	
FDA3:	A5 3C		XAM8	LDA	A1L	
FDA5:	09 07			ORA	#S07	SET TO FINISH AT
FDA7:	85 3E			STA	A2L	MOD 8=7
FDA9:	A5 3D			LDA	A1H	
FDAB:	85 3F			STA	A2H	
FDAD:	A5 3C		MODRCHK	LDA	A1L	
FDAF:	29 07			AND	#S07	
FDB1:	D0 03			BNE	DATAOUT	
FDB3:	20 92	FD	XAM	JSR	PRAI	
FDB6:	A9 A0		DATAOUT	LDA	#SA0	
FDB8:	20 ED	FD		JSR	COUT	OUTPUT BLANK
FDBB:	B1 3C			LDA	(A1L),Y	
FDBD:	20 DA	FD		JSR	PRBYTE	OUTPUT BYTE IN HEX
FDC0:	20 BA	FC		JSR	NXTAL	
FDC3:	90 E8			BCC	MODRCHK	CHECK IF TIME TO,
FDC5:	60		RTS4C	RTS		PRINT ADDR
FDC6:	4A		XAMPM	LSR	A	DETERMINE IF MON
FDC7:	90 EA			BCC	XAM	MODE IS XAM
FDC9:	4A			LSR	A	ADD, OR SUB
FDCA:	4A			LSR	A	
FDCE:	A5 3E			LDA	A2L	
FDCD:	90 02			BCC	ADD	
FDCF:	49 FF			EOR	#SFF	SUR: FORM 2'S COMPLEMENT
FDD1:	65 3C		ADD	ADC	A1L	
FDD3:	48			PHA		
FDD4:	A9 BD			LDA	#SBD	
FDD6:	20 ED	FD		JSR	COUT	PRINT '=', THEN RESULT
FDD9:	68			PLA		
FDDA:	48		PRBYTE	PHA		PRINT BYTE AS 2 HEX
Fddb:	4A			LSR	A	DIGITS, DESTROYS A-REG
FDDC:	4A			LSR	A	
FDDD:	4A			LSR	A	
FDDE:	4A			LSR	A	
FDDF:	20 E5	FD		JSR	PRHEXZ	
FDE2:	68			PLA		
FDE3:	29 0F		PRHEX	AND	#S0F	PRINT HEX DIG IN A-REG
FDE5:	09 B0		PRHEXZ	ORA	#S00	LSB'S
FDE7:	C9 BA			CMP	#SBA	
FDE9:	90 02			BCC	COUT	
FDEB:	69 06			ADC	#S06	
FDED:	6C 36	00	COUT	JMP	(CSWL)	VECTOR TO USER OUTPUT ROUTINE
FDF0:	C9 A0		COUT1	CMP	#SA0	
FDF2:	90 02			BCC	COUTZ	DON'T OUTPUT CTRL'S INVERSE
FDF4:	25 32			AND	INVFLG	MASK WITH INVERSE FLAG
FDF6:	84 35		COUTZ	STY	YSAV1	SAV Y-REG
FDF8:	48			PHA		SAV A-REG
FDF9:	20 FD	FB		JSR	VIDOUT	OUTPUT A-REG AS ASCII
FDFC:	68			PLA		RESTORE A-REG
FDFD:	A4 35			LDY	YSAV1	AND Y-RFG
FDFE:	60			RTS		THEN RETURN
FE00:	C6 34		BL1	DEC	YSAV	
FE02:	F0 9F			BEQ	XAM8	
FE04:	CA		BLANK	DEX		BLANK TO MON
FE05:	D0 16			RNE	SETMDZ	AFTER BLANK
FE07:	C9 BA			CMP	#SBA	DATA STORE MODE?
FE09:	D0 BB			BNE	XAMPM	NO, XAM, ADD OR SUB
FE0B:	85 31		STOR	STA	MODE	KEEP IN STORE MODE
FE0D:	A5 3E			LDA	A2L	

FE0F: 91 40		STA (A3L),Y	STORE AS LOW BYTE AS (A3)
FE11: E6 40		INC A3L	
FE13: D0 02		BNE RTS5	INCR A3, RETURN
FE15: E6 41		INC A3H	
FE17: 60	RTS5	RTS	
FE18: A4 34	SETMODE	LDY YSAV	SAVE CONVERTED ':', '+',
FE1A: B9 FF 01		LDA IN-1,Y	'-', '.', AS MODE.
FE1D: 85 31	SETMDZ	STA MODF	
FE1F: 60		RTS	
FE20: A2 01	LI'	LDX #S01	
FE22: B5 3E	LT2	LDA A2L,X	COPY A2 (2 BYTES) TO
FE24: 95 42		STA A4L,X	A4 AND A5
FE26: 95 44		STA A5L,X	
FE28: CA		DEX	
FE29: 10 F7		BPL LT2	
FE2B: 60		RTS	
FE2C: B1 3C	MOVE	LDA (A1L),Y	MOVE (A1 TO A2) TO
FE2E: 91 42		STA (A4L),Y	(A4)
FE30: 20 B4 FC		JSR NXTA4	
FE33: 90 F7		BCC MOVE	
FE35: 60		RTS	
FE36: B1 3C	VFY	LDA (A1L),Y	VERIFY (A1 TO A2) WITH
FE38: D1 42		CMP (A4L),Y	(A4)
FE3A: F0 1C		BEQ VFYOK	
FE3C: 20 92 FD		JSR PR41	
FE3F: B1 3C		LDA (A1L),Y	
FE41: 20 DA FD		JSR PR3YTE	
FE44: A9 A0		LDA #SA0	
FE46: 20 ED FD		JSR COUT	
FE49: A9 A8		LDA #SA8	
FE4B: 20 ED FD		JSR COUT	
FE4E: B1 42		LDA (A4L),Y	
FE50: 20 DA FD		JSR PR3YTE	
FE53: A9 A9		LDA #SA9	
FE55: 20 ED FD		JSR COUT	
FE58: 20 B4 FC	VFYOK	JSR NXTA4	
FE5B: 90 D9		BCC VFY	
FE5D: 60		RTS	
FE5E: 20 75 FE	LIST	JSR A1PC	MOVE A1 (2 BYTES) TO
FE61: A9 14		LDA #S14	PC IF SPEC'D AND
FE63: 48	LIST2	PHA	DISSEMPLE 20 INSTRS
FE64: 20 D0 F8		JSR INSTDSP	
FE67: 20 53 F9		JSR PCADJ	ADJUST PC EACH INSTR
FE6A: 85 3A		STA PCL	
FE6C: 84 3B		STY PCH	
FE6E: 68		PLA	
FE6F: 38		SEC	
FE70: E9 01		SBC #S01	NEXT OF 20 INSTRS
FE72: D0 EF		BNE LIST2	
FE74: 60		RTS	
FE75: 8A	A1PC	TXA	IF USER SPEC'D ADR
FE76: F0 07		BEQ A1PCRTS	COPY FROM A1 TO PC
FE78: B5 3C	A1PCLP	LDA A1L,X	
FE7A: 95 3A		STA PCL,X	
FE7C: CA		DEX	
FE7D: 10 F9		FPL A1PCLP	
FE7F: 60	A1PCRTS	RTS	
FE80: A0 3F	SETINV	LDY #S3F	SET FOR INVERSE VID
FE82: D0 02		BNE SETIFLG	VIA COUT1
FE84: A0 FF	SETNORM	LDY #SFF	SET FOR NORMAL VID
FE86: 84 32	SETIFLG	STY INVFLG	
FE88: 60		RTS	
FE89: A9 00	SETKBD	LDA #S00	SIMULATE PORT #0 INPUT
FE8B: 85 3E	INPORT	STA A2L	SPECIFIED (KEYIN ROUTINE)
FE8D: A2 38	INPRT	LDX #KSWL	
FE8F: A0 1B		LDY #KEYIN	
FE91: D0 08		BNE IOPRT	
FE93: A9 00	SETVID	LDA #S00	SIMULATE PORT #0 OUTPUT
FE95: 85 3E	OUTPORT	STA A2L	SPECIFIED (COUT1 ROUTINE)
FE97: A2 36	OUTPRT	LDX #CSWL	
FE99: A0 F0		LDY #COUT1	
FE9B: A5 3E	IOPRT	LDA A2L	SET PAM IN/OUT VECTORS
FE9D: 29 0F		AND #S0F	
FE9F: F0 06		BEQ IOPRT1	
FEA1: 09 C0		ORA #IOADR/256	
FEA3: A0 00		LDY #S00	
FEA5: F0 02		BEQ IOPRT2	
FEA7: A9 FD	IOPRT1	LDA #COUT1/256	
FEA9: 94 00	IOPRT2	STY LOC0,X	
FEAB: 95 01		STA LOC1,X	
FEAD: 60		RTS	
FEAE: EA		NOF	
FEAF: EA		NOF	
FEB0: 4C 00 E0	XBASIC	JMP BASIC	TO BASIC WITH SCRATCH
FEB3: 4C 03 E0	BASCONT	JMP BASIC2	CONTINUE BASIC

FEB6:	20 75 FE	GO	JSR	ALPC	ADR TO PC IF SPEC'D
FEB9:	20 3F FF		JSP	RESTOPE	RESTORE META REGS
FEBC:	6C 3A 00		JMP	(PCL)	GO TO USER SUBR
FEBF:	4C D7 FA	REGZ	J*P	REGDSP	TO REG DISPLAY
FEC2:	C6 34	TSPACE	DEC	YSAV	
FEC4:	20 75 FE	STEPZ	JSP	ALPC	ADR TO PC IF SPEC'D
FEC7:	4C 43 FA		JMP	STEP	TAKE ONE STEP
FECA:	4C F8 03	USP	JMP	USRADR	TO USP SUBR AT USRADR
FECD:	A9 40	WRITE	LDA	#\$40	
FECF:	20 C9 FC		JSR	HEADR	WRITE 10-SEC HEADER
FED2:	A0 27		LDY	#\$27	
FED4:	A2 00	WR1	LDX	#\$00	
FED6:	41 3C		EOP	(ALL,X)	
FED8:	48		PHA		
FED9:	A1 3C		LDA	(ALL,X)	
FEDB:	20 ED FE		JSR	WRPYTE	
FEDE:	20 BA FC		JSR	NXTA1	
FEE1:	A0 1D		LDY	#\$1D	
FEE3:	68		PLA		
FEE4:	90 EE		BCC	WR1	
FEE6:	A0 22		LDY	#\$22	
FEE8:	20 ED FE		JSR	WRPYTE	
FEEB:	F0 40		BEC	BELL	
FEED:	A2 10	WRBYTE	LDX	#\$10	
FEEF:	0A	WRBYT2	ASL	A	
FEF0:	20 D6 FC		JSR	WRBIT	
FEF3:	D0 FA		BNE	WRBYT2	
FEF5:	60		RTS		
FEF6:	20 00 FE	CRMON	JSR	BL1	HANDLE CR AS BLANK
FEF9:	68		PLA		THEN POP STACK
FEFA:	68		PLA		AND RTN TO MON
FEFB:	D0 6C		BNE	MONZ	
FEFD:	20 FA FC	READ	JSR	RD2BIT	FIND TAPEIN EDGE
FF00:	A9 16		LDA	#\$16	
FF02:	20 C9 FC		JSR	HEADR	DEJAY 3.5 SECONDS
FF05:	85 2E		STA	CHKSUM	INIT CHKSUM=\$FF
FF07:	20 FA FC		JSR	RD2BIT	FIND TAPEIN EDGE
FF0A:	A0 24	RD2	LDY	#\$24	LOOK FOR SYNC BIT
FF0C:	20 FD FC		JSR	RDBIT	(SHORT 0)
FF0F:	B0 F9		BCS	RD2	LOOP UNTIL FOUND
FF11:	20 FD FC		JSR	RUBIT	SKIP SECOND SYNC H-CYCLE
FF14:	A0 3B		LDY	#\$3B	INDEX FOR 0/1 TEST
FF16:	20 EC FC	RD3	JSR	RDBYTE	READ A BYTE
FF19:	81 3C		STA	(ALL,X)	STORE AT (A1)
FF1B:	45 2E		EOR	CHKSUM	
FF1D:	85 2E		STA	CHKSUM	UPDATE RUNNING CHKSUM
FF1F:	20 3A FC		JSR	NXTA1	INCR A1, COMPARE TO A2
FF22:	A0 35		LDY	#\$35	COMPENSATE 0/1 INDEX
FF24:	90 F0		BCC	RD3	LOOP UNTIL DONE
FF26:	20 EC FC		JSR	RDBYTE	READ CHKSUM BYTE
FF29:	C5 2E		CMP	CHKSUM	
FF2B:	F0 0D		BEO	BELL	GOOD, SOUND BELL AND RETURN
FF2D:	A9 C5	PRERR	LDA	#\$C5	
FF2F:	20 ED FD		JSR	COUT	PRINT "ERR", THEN BELL
FF32:	A9 D2		LDA	#\$D2	
FF34:	20 ED FD		JSR	COUT	
FF37:	20 ED FD		JSR	COUT	
FF3A:	A9 87	BELL	LDA	#\$87	OUTPUT BELL AND RETURN
FF3C:	4C ED FD		JAP	COUT	
FF3F:	A5 48	RESTORE	LDA	STATUS	RESTORE 6502 PEG CONTENTS
FF41:	48		PHA		USED BY DEBUG SWAPE
FF42:	A5 45		LDA	ACC	
FF44:	A6 46	RESTRI1	LDX	XREG	
FF46:	A4 47		LDY	YREG	
FF48:	28		PLP		
FF49:	60		RTS		
FF4A:	85 45	SAVE	STA	ACC	SAVE 6502 REG CONTENTS
FF4C:	86 46	SAV1	STX	XREG	
FF4E:	84 47		STY	YREG	
FF50:	08		PHP		
FF51:	68		PLA		
FF52:	85 48		STA	STATUS	
FF54:	BA		TSX		
FF55:	86 49		STX	SPNT	
FF57:	D8		CLD		
FF58:	60		RTS		
FF59:	20 84 FE	RESET	JSR	SETNORM	SET SCREEN MODE
FF5C:	20 2F FB		JSR	INIT	AND INIT KBD/SCREEN
FF5F:	20 93 FE		JSR	SETVID	AS I/O DEV'S
FF62:	20 89 FE		JSR	SETKBD	
FF65:	D8	MON	CLD		MUST SET HEX MODE!
FF66:	20 3A FF		JSR	BELL	
FF69:	A9 AA	MONZ	LDA	#\$AA	'*' PROMPT FOR MON
FF6B:	85 33		STA	PROMPT	
FF6D:	20 67 FD		JSR	GETLNZ	READ A LINE

FF70: 20 C7 FF		JSR ZMODE	CLEAR MON MODE, SCAN IDX
FF73: 20 A7 FF	NXTITM	JSR GETNUM	GET ITEM, NON-HEX
FF76: 84 34		STY YSAV	CHAR IN A-REG
FF78: A0 17		LDY #S17	X-REG=0 IF NO HEX INPUT
FF7A: 88	CHRSRCH	DEY	
FF7B: 30 E8		BMI MON	NOT FOUND, GO TO MON
FF7D: D9 CC FF		CMP CRTBL,Y	FIND CMND CHAR IN TEL
FF80: D0 F8		BNE CHRSPCH	
FF82: 20 BE FF		JSR TOSUB	FOUND, CALL CORRESPONDING
FF85: A4 34		LDY YSAV	SUBROUTINE
FF87: 4C 73 FF		JMP NXTITM	
FF8A: A2 03	DIG	LDX #S03	
FF8C: 0A		ASL A	
FF8D: 0A		ASL A	
FF8E: 0A		ASL A	GET HEX DIG,
FF8F: 0A		ASL A	SHIFT INTO A2
FF90: 0A	NXTBIT	ASL A	
FF91: 26 3E		ROL A2L	
FF93: 26 3F		ROL A2H	
FF95: CA		DEX	LEAVE X=\$FF IF DIG
FF96: 10 F8		EPL NXTBIT	
FF98: A5 31	NXTEAS	LDA MODE	
FF9A: D0 06		RNE NXTES2	IF MODF IS ZERO
FF9C: B5 3F		LDA A2H,X	THEN COPY A2 TO
FF9E: 95 3D		STA A1H,X	A1 AND A3
FFA0: 95 41		STA A3H,X	
FFA2: B8	NXTBS2	INX	
FFA3: F0 F3		BEQ NXTBAS	
FFA5: D0 06		BNE NXTCPN	
FFA7: A2 00	GETNUM	LDX #S0C	CLEAR A2
FFA9: 86 3E		STX A2L	
FFAB: 86 3F		STX A2H	
FFAD: B9 00 02	NXTCHP	LDA IN,Y	GET CHAR
FFB0: C8		INY	
FFB1: 49 B0		FOR #S80	
FFB3: C9 0A		CMP #S0A	
FFB5: 90 D3		BCC DIG	IF HEX DIG, THEN
FFB7: 69 88		ADC #S88	
FFB9: C9 FA		CMP #SFA	
FFB3: B0 CD		BCS DIG	
FFBD: 60		PTS	
FFBE: A9 FE	TOSUB	LEA #CO/256	PUSH HIGH-ORDER
FFC0: 48		PHA	SUBR ADR ON STK
FFC1: B9 E3 FF		LEA SUBTFL,Y	PUSH LOW ORDER
FFC4: 48		PHA	SUBR ADR ON STK
FFC5: A5 31		LDA MODE	
FFC7: A0 00	ZMODE	LDY #S00	CLP MODE, OLD MODE
FFC9: 84 31		STY MODE	TO A-REG
FFCB: 60		RTS	GO TO SUBR VIA PTS
FFCC: BC	CHRTRL	DFB \$3C	F("CTRL-C")
FFCD: B2		DFB \$B2	F("CTRL-Y")
FFCE: BE		DFB \$3E	F("CTRL-E")
FFCF: ED		DFB \$E0	F(" ")
FFD0: EF		DFB \$FF	F("V")
FFD1: C4		DFB \$C4	F("CTRL-K")
FFD2: EC		DFB \$FC	F("S")
FFD3: A9		DFB \$A9	F("CTRL-P")
FFD4: B8		DFB \$B8	F("CTRL-B")
FFD5: A6		DFB \$A6	F("-")
FFD6: A4		DFB \$A4	F("+")
FFD7: 06		DFB \$06	F("#") (F=EX-OP \$E0+\$89)
FFD8: 95		DFB \$95	F("<")
FFD9: 07		DFB \$07	F("N")
FFDA: 02		DFB \$02	F("I")
FFDB: 05		DFB \$05	F("L")
FFDC: F0		DFB \$F0	F("Z")
FFDD: 00		DFB \$00	F("G")
FFDE: EB		DFB \$EB	F("R")
FFDF: 93		DFB \$93	F(":")
FFE0: A7		DFB \$A7	F(".")
FFE1: C6		DFB \$C6	F("CR")
FFE2: 99		DFB \$99	F(BLANK)
FFE3: B2	SUBTFL	DFB #BASCONT-1	
FFE4: C9		DFB #USR-1	
FFE5: BE		DFB #REGZ-1	
FFE6: C1		DFB #TRACE-1	
FFE7: 35		DFB #VPY-1	
FFE8: 8C		DFB #INPRT-1	
FFE9: C3		DFB #STEPZ-1	
FFFA: 96		DFB #OUTPRT-1	
FFFB: AF		DFB #XPASIC-1	
FFFC: 17		DFB #SETMODE-1	
FFFD: 17		DFB #SETMODE-1	
FFFE: 2B		DFB #MOVE-1	
FFFE: 1F		DFB #LT-1	

FFF0: 83	DFB #SETNORM-1
FFF1: 7F	DFB #SETINV-1
FFF2: 5D	DFB #LIST-1
FFF3: CC	DFB #WRITE-1
FFF4: F5	DFB #GO-1
FFF5: FC	DFB #READ-1
FFF6: 17	DFB #SETMODE-1
FFF7: 17	DFB #SETMODE-1
FFF8: F5	DFB #CRMON-1
FFF9: 03	DFB #BLANK-1
FFFA: FB	DFB #NMI NMI VECTOR
FFFB: 03	DFB #NMI/256
FFFC: 59	DFB #RESET RESET VECTOR
FFFD: FF	DFB #RESET/256
FFFE: 86	DFB #IRQ IRQ VECTOR
FFFF: FA	DFB #IRQ/256
	EQU \$3C

XQTNZ

```

*****
*
*       APPLE-II       *
*   MINI-ASSEMBLER   *
*
*   COPYRIGHT 1977 BY *
*   APPLE COMPUTER INC.*
*
*   ALL RIGHTS RESEVED*
*
*       S. WOZNIAK    *
*       A. BAUM       *
*
*****

```

TITLE "APPLE-II MINI-ASSEMBLER"

```

FORMAT      EPZ  $2E
LENGTH      EPZ  $2F
MODE        EPZ  $31
PROMPT      EPZ  $33
YSAV        EPZ  $34
L           EPZ  $35
PCL         EPZ  $3A
PCH         EPZ  $3B
ALH         EPZ  $3C
A2L         EPZ  $3E
A2H         EPZ  $3F
A4L         EPZ  $42
A4H         EPZ  $43
FMT         EPZ  $44
IN          EQU  $200
INSDS2      EQU  $F88E
INSTDSF     EQU  $F8D0
PRBL2       EQU  $F94A
PCADJ       EQU  $F953
CHAR1       EQU  $F9B4
CHAR2       EQU  $F9BA
MNEHL       EQU  $F9C0
MNEAP       EQU  $FA00
CURSUP      EQU  $FC1A
GETLNZ      EQU  $FD67
COUT        EQU  $FDED
BL1         EQU  $FE00
ALPCLP      EQU  $FE78
EELL        EQU  $FF3A
GETNUM      EQU  $FFA7
TOSUB       EQU  $FFFE
ZMODE       EQU  $FFFC7
CHRTBL      EQU  $FFCC
ORG         $F500

```

```

F500: E9 81
F502: 4A
F503: D0 14
F505: A4 3F
F507: A6 3E
F509: D0 01
F50B: 88
F50C: CA
F50D: 8A
F50E: 18
F50F: E5 3A
F511: 85 3E
F513: 10 01
F515: C8
F516: 98

```

```

REL      SEC  #S01
         LSP  A
         BNE  IFR3
         LDY  A2H
         LDY  A2L
         BNE  REL2
         DEY
REL2     DEX
         TXA
         CLC
         SBC  PCL
         STA  A2L
         BPL  REL3
         INY
REL3     TYA

```

```

IS FMT COMPATIBLE
WITH RELATIVE MODE?
NO.
DOUBLE DECREMENT

```

FORM ADDR-PC-2

F517:	E5 3B		SBC	PCH	
F519:	D0 6B	ERR3	RNE	ERR	ERROR IF >1-BYTE BRANCH
F51B:	A4 2F	FINDOP	LDY	LENGTH	
F51D:	B9 3D 00	FNDOP2	LDA	AIH,Y	MOVE INST TO (PC)
F520:	91 3A		STA	(PCL),Y	
F522:	88		DEY		
F523:	10 F8		BPL	FNDOP2	
F525:	20 1A FC		JSR	CURSUP	
F528:	20 1A FC		JSP	CURSUP	RESTORE CURSOR
F52B:	20 D0 F8		JSR	INSTDSP	TYPE FORMATTED LINE
F52E:	20 53 F9		JSR	PCADJ	UPDATE PC
F531:	84 3B		STY	PCH	
F533:	85 3A		STA	PCL	
F535:	4C 95 F5		JMP	NXTLINE	GET NEXT LINE
F538:	20 BE FF	FAKEMON3	JSR	TOSUB	GO TO DELIM HANDLER
F53B:	A4 34		LDY	YSAV	RESTORE Y-INDEX
F53D:	20 A7 FF	FAKEMON	JSR	GETNUM	READ PARAM
F540:	84 34		STY	YSAV	SAVE Y-INDEX
F542:	A0 17		LDY	#\$17	INIT DELIMITER INDEX
F544:	88	FAKEMON2	DEY		CHECK NEXT DELIM
F545:	30 4B		BMI	RESETZ	ERR IF UNRECOGNIZED DELIM
F547:	D9 CC FF		CMP	CHRTBL,Y	COMPARE WITH DELIM TABLE
F54A:	D0 F8		BNE	FAKEMON2	NO MATCH
F54C:	C0 15		CPY	#\$15	MATCH, IS IT CR?
F54E:	D0 E8		BNE	FAKEMON3	NO, HANDLE IT IN MONITOR
F550:	A5 31		LDA	MODE	
F552:	A0 00		LDY	#\$0	
F554:	C6 34		DEC	YSAV	
F556:	20 00 FE		JSR	BL1	HANDLE CR OUTSIDE MONITOR
F559:	4C 95 F5		JMP	NXTLINE	
F55C:	A5 3D	TRYNEXT	LDA	AIH	GET TRIAL OPCODE
F55E:	20 8E F8		JSR	INSDS2	GET FMT+LENGTH FOR OPCODE
F561:	AA		TAX		
F562:	BD 00 FA		LDA	MNEMR,X	GET LOWER MNEMONIC BYTE
F565:	C5 42		CMP	A4L	MATCH?
F567:	D0 13		BNE	NEXTOP	NO, TRY NEXT OPCODE
F569:	BD C0 F9		LDA	MNEML,X	GET UPPER MNEMONIC BYTE
F56C:	C5 43		CMP	A4H	MATCH?
F56E:	D0 0C		BNE	NEXTOP	NO, TRY NEXT OPCODE.
F570:	A5 44		LDA	FMT	
F572:	A4 2E		LDY	FORMAT	GET TRIAL FORMAT
F574:	C0 9D		CPY	#\$9D	TRIAL FORMAT RELATIVE?
F576:	F0 88		BEQ	REL	YES.
F578:	C5 2E	NREL	CMP	FORMAT	SAME FORMAT?
F57A:	F0 9F		BEQ	FINDOP	YES.
F57C:	C6 3D	NEXTOP	DEC	AIH	NO, TRY NEXT OPCODE
F57E:	D0 DC		BNE	TRYNEXT	
F580:	E6 44		INC	FMT	NO MORE, TRY WITH LEN=2
F582:	C6 35		DEC	L	NO L=2 ALREADY?
F584:	F0 D6		BEQ	TRYNEXT	NO.
F586:	A4 34	ERR	LDY	YSAV	YES, UNRECOGNIZED INST.
F588:	98	ERR2	TYA		
F589:	AA		TAX		
F58A:	20 4A F9		JSR	PRBL2	PRINT ~ UNDER LAST READ
F58D:	A9 DE		LDA	#\$DE	CHAR TO INDICATE ERROR
F58F:	20 ED FD		JSR	COUT	POSITION.
F592:	20 3A FF	RESETZ	JSR	BELL	
F595:	A9 A1	NXTLINE	LDA	#\$A1	'!'
F597:	85 33		STA	PROMPT	INITIALIZE PROMPT
F599:	20 67 FD		JSR	GETLNZ	GET LINE.
F59C:	20 C7 FF		JSR	ZMODE	INIT SCREEN STUFF
F59F:	AD 00 02		LDA	IN	GET CHAR
F5A2:	C9 A0		CMP	#\$A0	ASCII BLANK?
F5A4:	F0 13		BEQ	SPACE	YES
F5A6:	C8		INY		
F5A7:	C9 A4		CMP	#\$A4	ASCII '\$' IN COL 1?
F5A9:	F0 92		BEQ	FAKEMON	YES, SIMULATE MONITOR
F5AB:	88		DEY		NO, BACKUP A CHAR
F5AC:	20 A7 FF		JSR	GETNUM	GET A NUMBER
F5AF:	C9 93		CMP	#\$93	':' TERMINATOR?
F5B1:	D0 D5	ERR4	BNI	ERR2	NO, ERR.
F5B3:	8A		TXA		
F5B4:	F0 D2		BEQ	ERR2	NO ADR PRECEDING COLON.
F5B6:	20 78 FE		JSR	AIPLCLP	MOVE ADR TO PCL, PCH.
F5B9:	A9 03	SPACE	LDA	#\$3	COUNT OF CHARS IN MNEMONIC
F5BB:	85 3D		STA	AIH	
F5BD:	20 34 F6	NXTMN	JSR	GETNSP	GET FIRST MNEM CHAR.
F5C0:	0A	NXTM	ASL	A	
F5C1:	E9 BE		SBC	#\$BE	SUBTRACT OFFSET
F5C3:	C9 C2		CMP	#\$C2	LEGAL CHAR?
F5C5:	90 C1		BCC	ERR2	NO.
F5C7:	0A		ASL	A	COMPRESS-LEFT JUSTIFY
F5C8:	0A		ASL	A	
F5C9:	A2 04		LDX	#\$4	
F5CB:	0A	NXTM2	ASL	A	DO 5 TRIPLE WORD SHIFTS

F5CC: 26 42		ROL	A4L	
F5CE: 26 43		ROL	A4H	
F5D0: CA		DEX		
F5D1: 10 F8		BPL	NXTM2	
F5D3: C6 3D		DEC	A1H	DONE WITH 3 CHARS?
F5D5: F0 F4		BEQ	NXTM2	YES, BUT DO 1 MORE SHIFT
F5D7: 10 E4		BPL	NXTMN	NO
F5D9: A2 05	FORM1	LDX	#S5	5 CHARS IN ADDR MODE
F5DB: 20 34 F6	FORM2	JSR	GETNSP	GPT FIRST CHAR OF ADDR
F5DE: 84 34		STY	YSAV	
F5E0: DD B4 F9		CMP	CHAR1,X	FIRST CHAR MATCH PATTERN?
F5E3: D0 13		BNE	FORM3	NO
F5E5: 20 34 F6		JSR	GETNSP	YES, GET SECOND CHAR
F5E8: DD BA F9		CMP	CHAR2,X	MATCHES SECOND HALF?
F5EB: F0 0D		BEQ	FORM5	YES
F5ED: BD BA F9		LDA	CHAR2,X	NO, IS SECOND HALF ZERO?
F5F0: F0 07		BEQ	FORM4	YES.
F5F2: C9 A4		CMP	#SA4	NO, SECOND HALF OPTIONAL?
F5F4: F0 03		BEQ	FORM4	YES.
F5F6: A4 34		LCY	YSAV	
F5F8: 18	FORM3	CLC		CLEAR BIT-NO MATCH
F5F9: 88	FORM4	DEY		BACK UP 1 CHAR
F5FA: 26 44	FORM5	ROL	FMT	FORM FORMAT BYTE
F5FC: E0 03		CPY	#S3	TIME TO CHECK FOR ADDR.
F5FE: D0 0D		BNE	FORM7	NO
F600: 20 A7 FF		JSR	GETNUM	YES
F603: A5 3F		LDA	A2H	
F605: F0 01		BEQ	FORM6	HIGH-ORDER BYTE ZERO
F607: E8		INX		NO, INCR FOR 2-BYTE
F608: 86 35	FORM6	STX	L	STORE LENGTH
F60A: A2 03		LDX	#S3	RELOAD FORMAT INDEX
F60C: 88		DEY		BACKUP A CHAR
F60D: 86 3D	FORM7	STX	A1H	SAVE INDEX
F60F: CA		DEX		DONE WITH FORMAT CHECK?
F610: 10 C9		BPL	FORM2	NO.
F612: A5 44		LDA	FMT	YES, PUT LENGTH
F614: 0A		ASL	A	IN LOW BITS
F615: 0A		ASL	A	
F616: 05 35		ORA	L	
F618: C9 20		CMP	#S20	
F61A: B0 06		RCS	FORM8	ADD '\$' IF NONZERO LENGTH
F61C: A6 35		LDX	L	AND DON'T ALREADY HAVE IT
F61E: F0 02		BEQ	FORM8	
F620: 09 80		ORA	#S80	
F622: 85 44	FORM8	STA	FMT	
F624: 84 34		STY	YSAV	
F626: B9 00 02		LDA	IN,Y	GET NEXT NONBLANK
F629: C9 BB		CMP	#SBB	';' START OF COMMENT?
F62B: F0 04		BEQ	FORM9	YES
F62D: C9 8D		CMP	#S8D	CARRIAGE RETURN?
F62F: D0 80		BNE	ERF4	NO, ERF.
F631: 4C 5C F5	FORM9	JMP	TRYNEXT	
F634: B9 00 02	GFTNSP	LDA	IN,Y	
F637: C8		INY		
F638: C9 A0		CMP	#SA0	GET NEXT NON BLANK CHAR
F63A: F0 F8		BEQ	GETNSP	
F63C: 60		RTS		
		ORG	\$F666	
F666: 4C 92 F5	MINASM	JMP	RESETZ	



```

*****
*
* APPLE-II FLOATING *
* POINT ROUTINES *
*
* COPYRIGHT 1977 BY *
* APPLE COMPUTER INC. *
*
* ALL RIGHTS RESERVED *
*
* S. WOZNIAK *
*
*****

```

TITLE "FLOATING POINT ROUTINES"

	SIGN	EPZ	\$F3	
	X2	EPZ	\$F4	
	M2	EPZ	\$F5	
	X1	EPZ	\$F8	
	M1	EPZ	\$F9	
	E	EPZ	\$FC	
	OVLOC	ORG	\$3F5	
		ORG	\$F425	
F425:	18	ADD	CLC	CLEAR CARRY.
F426:	A2 02		LDX #52	INDEX FOR 3-BYTE ADD.
F428:	B5 F9	ADD1	LDA M1,X	
F42A:	75 F5		ADC M2,X	ADD A BYTE OF MANT2 TO MANT1.
F42C:	95 F9		STA M1,X	
F42E:	CA		DEY	INDEX TO NEXT MORE SIGNIF. BYTE.
F42F:	10 F7		BPL ADD1	LOOP UNTIL DONE.
F431:	60		RTS	RETURN
F432:	06 F3	MD1	ASL SIGN	CLEAR LSB OF SIGN.
F434:	20 37 F4		JSR ABSWAP	ABS VAL OF M1, THEN SWAP WITH M2
F437:	24 F9	ABSWAP	BIT M1	MANT1 NEGATIVE?
F439:	10 05		BPL ABSWAP1	NO, SWAP WITH MANT2 AND RETURN.
F43B:	20 A4 F4		JSR FCOMPL	YES, COMPLEMENT IT.
F43E:	E6 F3		INC SIGN	INCR SIGN, COMPLEMENTING LSB.
F440:	38	ABSWAP1	SEC	SET CARRY FOR RETURN TO MUL/DIV.
F441:	A2 04	SWAP	LDX #54	INDEX FOR 4-BYTE SWAP.
F443:	94 FB	SWAP1	STY E-1,X	
F445:	B5 F7		LDA X1-1,X	SWAP A BYTE OF EXP/MANT1 WITH
F447:	B4 F3		LDY X2-1,X	EXP/MANT2 AND LEAVE A COPY OF
F449:	94 F7		STY X1-1,X	MANT1 IN E (3 BYTES). E+3 USED
F44B:	95 F3		STA X2-1,X	
F44D:	CA		DFX	ADVANCE INDEX TO NEXT BYTE.
F44E:	D0 F3		BNE SWAP1	LOOP UNTIL DONE.
F450:	60		RTS	RETURN
F451:	A9 8E	FLOAT	LDA #5EE	INIT EXP1 TO 14,
F453:	85 F8		STA X1	THEN NORMALIZE TO FLOAT.
F455:	A5 F9	NOPM1	LOA M1	HIGH-ORDER MANT1 BYTE.
F457:	C9 C0		CMF #5C0	UPPER TWO BITS UNEQUAL?
F459:	30 0C		BMI RTS1	YES, RETURN WITH MANT1 NORMALIZED
F45B:	C6 F8		DEC X1	DECREMENT EXP1.
F45D:	06 FE		ASL M1+2	
F45F:	26 FA		ROL M1+1	SHIFT MANT1 (3 BYTES) LEFT.
F461:	26 F9		ROL M1	
F463:	A5 F8	NORM	LDA X1	EXP1 ZERO?
F465:	D0 EE		BNE NORM1	NO, CONTINUE NORMALIZING.
F467:	60	RTS1	PTS	RETURN.
F468:	20 A4 F4	FSUB	JSR FCOMPL	COMPL MANT1, CLEARS CARRY UNLESS 0
F46B:	20 7B F4	SWPALGN	JSR ALGNSWP	RIGHT SHIFT MANT1 OR SWAP WITH
F46E:	A5 F4	FADD	LDA X2	
F470:	C5 F8		CMF X1	COMPARE EXP1 WITH EXP2.
F472:	D0 F7		BNE SWPALGN	IF #,SWAP ADDENDS OR ALIGN MANTS.
F474:	20 25 F4		JSR ADD	ADD ALIGNED MANTISSAS.
F477:	50 EA	ADDEND	BVC NORM	NO OVERFLOW, NORMALIZE RESULT.
F479:	70 05		BVS RTLOG	OV: SHIFT M1 RIGHT, CARRY INTO SIGN

F47B:	90	C4	ALGNBWP	BCC	SWAP	SWAP IF CARRY CLEAR, * RTAR	ELSE SHIFT RIGHT ARITH.
F47D:	A5	F9	RTAR	LDA	M1	SIGN OF MANT1 INTO CARRY FOR F47F: 0A	RIGHT ARITH SHIFT.
F480:	E6	F8	RTLOC	INC	X1	INCR X1 TO ADJUST FOR RIGHT SHIFT	
F482:	F0	75		REC	OVFL	EXPL OUT OF RANGE.	
F484:	A2	FA	RTLOG1	LDX	#\$FA	INDEX FOR 6:BYTE RIGHT SHIFT.	
F486:	76	FF	ROPI	ROR	E+3,X		
F488:	E8			INX		NEXT BYTE OF SHIFT.	
F489:	D0	FB		BNE	ROR1	LOOP UNTIL DONE.	
F48B:	60			RTS		RETURN.	
F48C:	20	32	F4	FMUL	JSR	MD1	ABS VAL OF MANT1, MANT2.
F48F:	65	F8		ADC	X1	ADD EXP1 TO EXP2 FOR PRODUCT EXP	
F491:	20	E2	F4	JSR	MD2	CHECK PROD. EXP AND PREP. FOR MUL	
F494:	18			CLC		CLEAR CARRY FOR FIRST BIT.	
F495:	20	84	F4	MUL1	JSR	RTLOG1	M1 AND E RIGHT (PROD AND MPLIEP)
F498:	90	03		BCC	MUL2	IF CARRY CLEAR, SKIP PARTIAL PROD	
F49A:	20	25	F4	JSR	ADD	ADD MULTIPLICAND TO PRODUCT.	
F49D:	88			DEY		NEXT MUL ITERATION.	
F49E:	10	F5		9PL	MUL1	LOOP UNTIL DONE.	
F4A0:	46	F3		LSR	SIGN	TEST SIGN LSS.	
F4A2:	90	2F		NORMX	PCC	IF EVEN,NORMALIZE PROD,ELSE COMP	
F4A4:	38			FCOMPL	SEC	SET CARRY FOR SUBTRACT.	
F4A5:	A2	03		LDX	#\$3	INDEX FOR 3-BYTE SUBTRACT.	
F4A7:	A9	00		LDA	#\$0	CLEAR A.	
F4A9:	F5	F8		SBC	X1,X	SUBTRACT BYTE OF EXP1.	
F4AB:	95	F8		STA	X1,X	RESTORE IT.	
F4AD:	CA			DEX		NEXT MORE SIGNIFICANT BYTE.	
F4AE:	D0	F7		BNE	COMPL1	LOOP UNTIL DONE.	
F4B0:	F0	C5		BEQ	ADDEND	NORMALIZE (OR SHIFT RT IF OVFL).	
F4B2:	20	32	F4	FDIV	JSR	MD1	TAKE ABS VAL OF MANT1, MANT2.
F4B5:	E5	F8		SRC	X1	SUBTRACT EXP1 FROM EXP2.	
F4B7:	20	E2	F4		JSR	MD2	SAVE AS QUOTIENT EXP.
F4BA:	38			DIV1	SEC	SET CARRY FOR SUBTRACT.	
F4BB:	A2	02		LDX	#\$2	INDEX FOR 3-PYTE SUBTRACTION.	
F4BD:	B5	F5		DIV2	LDA	M2,X	
F4BF:	F5	FC		SBC	E,X	SUBTRACT A BYTE OF E FROM MANT2.	
F4C1:	48			PHA		SAVE ON STACK.	
F4C2:	CA			DEX		NEXT MORE SIGNIFICANT BYTE.	
F4C3:	10	F8		9PL	DIV2	LOOP UNTIL DONE.	
F4C5:	A2	FD		LDX	#\$FD	INDEX FOR 3-BYTE CONDITIONAL MOVE	
F4C7:	68			DIV3	PLA	PULL BYTE OF DIFFERENCE OFF STACK	
F4C8:	90	02		BCC	DIV4	IF M2<E THEN DON'T RESTORE M2.	
F4CA:	95	F8		STA	M2+3,X		
F4CC:	E8			DIV4	INX	NEXT LESS SIGNIFICANT BYTE.	
F4CD:	D0	F8		BNE	DIV3	LOOP UNTIL DONE.	
F4CF:	26	FB		ROL	M1+2		
F4D1:	26	FA		ROL	M1+1	ROLL QUOTIENT LEFT,CARRY INTO LSB	
F4D3:	26	F9		ROL	M1		
F4D5:	06	F7		ASL	M2+2		
F4D7:	26	F6		ROL	M2+1	SHIFT DIVIDEND LEFT.	
F4D9:	26	F5		ROL	M2		
F4DB:	B0	1C		BCC	OVFL	OVFL IS DUE TO UNNORMED DIVISOR	
F4DD:	88			DEY		NEXT DIVIDE ITERATION.	
F4DE:	D0	DA		BNE	DIV1	LOOP UNTIL DONE 23 ITERATIONS.	
F4E0:	F0	BE		BEQ	MDFND	NORM. QUOTIENT AND CORRECT SIGN.	
F4E2:	86	FB		MD2	STX	M1+2	
F4E4:	86	FA		STX	M1+1	CLEAR MANT1 (3 BYTES) FOR MUL/DIV.	
F4E6:	86	F9		STX	#1		
F4E8:	B0	0D		BCC	OVCHK	IF CALC. SET CARRY,CHECK FOR OVFL	
F4EA:	30	04		BMI	MD3	IF NEG THEN NO UNDERFLOW.	
F4EC:	68			PLA		POP ONE RETURN LEVEL.	
F4ED:	68			PLA			
F4EE:	90	B2		BCC	NORMX	CLEAR X1 AND RETURN.	
F4F0:	49	80		MD3	EOR	#\$80	COMPLEMENT SIGN BIT OF EXPONENT.
F4F2:	85	F8		STA	X1	STORE IT.	
F4F4:	A0	17		L9Y	#\$17	COUNT 24 MUL/23 DIV ITERATIONS	
F4F6:	60			PTS		RETURN.	
F4F7:	10	F7		OVCHK	BPL	MD3	IF POSITIVE EXP THEN NO OVFL.
F4F9:	4C	F5	03	OVFL	JMP	OVLOC	
					ORG	\$F63D	
F63D:	20	7D	F4	FIX1	JSR	RTAR	
F640:	A5	F8		FIX	LDA	X1	
F642:	10	13			9PL	UNDFL	
F644:	C9	8E			CMP	#\$8E	
F646:	D0	F5			BNE	FIX1	
F648:	24	F9			BIT	M1	
F64A:	10	0A			9PL	FIXPTS	
F64C:	A5	FB			LDA	M1+2	
F64E:	F0	06			BFO	FIXRTS	
F650:	E6	FA			INC	M1+1	
F652:	D0	02			BNE	FIXRTS	
F654:	E6	F9			INC	M1	
F656:	60			FIXRTS	PTS		
F657:	A9	00		UNDFL	LDA	#\$0	
F659:	85	F9			STA	M1	
F65B:	85	FA			STA	M1+1	
F65D:	60				RTS		

```

*****
*
*   APPLE-II PSEUDO
* MACHINE INTERPRETER
*
*   COPYRIGHT 1977
* APPLE COMPUTER INC
*
* ALL RIGHTS RESERVED
*
*   S. WOZNIAK
*
*****

```

TITLE "SWEET16 INTERPRETER"

```

ROL      EPZ  $0
R0H      EPZ  $1
R14H     EPZ  $10
R15L     EPZ  $1E
R15H     EPZ  $1F
S16PAG   EQU  $F7
SAVE     EQU  $FF4A
RESTORE  EQU  $FF3F
          ORG  $F689

F689: 20 4A FF SW16 JSR SAVE      PRESERVE 6502 REG CONTENTS
F68C: 68          PLA           INIT SWEET16 PC
F68D: 85 1E      STA R15L      FROM RETURN
F68F: 68          PLA           ADDRESS
F690: 85 1F      STA F15H     INTERPRET AND EXECUTE
F692: 20 98 F6 SW16B JSP SW16C  ONE SWEET16 INSTR.
F695: 4C 92 F6   JMP SW16B
F698: E6 1E     SW16C INC R15L  INCP SWEET16 PC FOR FETCH
F69A: D0 02     SW16C BNE SW16D
F69C: E6 1F     SW16C INC R15H
F69E: A9 F7     SW16D LDA #S16PAG
F6A0: 48          PHA           PUSH ON STACK FOR PTS
F6A1: A0 00     SW16D LDY #S0
F6A3: B1 1E     SW16D LDA (R15L),Y  FETCH INSTR
F6A5: 29 0F     SW16D AND #SF      MASK REG SPECIFICATION
F6A7: 0A       SW16D ASL A       DOUBLE FOR 2-BYTE REGISTERS
F6A8: AA       SW16D TAX          TO X-REG FOR INDEXING
F6A9: 4A       SW16D LSR A
F6AA: 51 1E     SW16D EOR (R15L),Y NOW HAVE OPCODE
F6AC: F0 0B     SW16D BEQ TOBR    IF ZERO THEN NON-REG OP
F6AE: 86 1D     SW16D STX R14H    INDICATE 'PRIOR RESULT REG'
F6B0: 4A       SW16D LSR A
F6B1: 4A       SW16D LSR A       OPCODE*2 TO LSR'S
F6B2: 4A       SW16D LSR A
F6B3: A8       SW16D TAY          TO Y-REG FOR INDEXING
F6B4: B9 E1 F6 SW16D LDA OPTBL-2,Y LOW-ORDER ADR BYTE
F6B7: 48       SW16D PHA           ONTO STACK
F6B8: 60       SW16D PTS          GOTO REG-OP ROUTINE
F6B9: E6 1E     TOBR INC R15L
F6BB: D0 02     TOBR BNE TOBR2   INCR PC
F6BD: E6 1F     TOBR INC R15H
F6BF: BD E4 F6 TOBR2 LDA OPTBL,X  LOW-ORDER ADR BYTE
F6C2: 48       TOBR2 PHA           ONTO STACK FOR NON-REG OP
F6C3: A5 1D     TOBR2 LDA R14H    'PRIOR RESULT REG' INDEX
F6C5: 4A       TOBR2 LSR A       PREPARE CARRY FOR BC, BNC.
F6C6: 60       TOBR2 PTS          GOTO NON-REG OP ROUTINE
F6C7: 68       TOBR2 PLA           LOP RETURN ADDRESS
F6C8: 68       TOBR2 PLA
F6C9: 20 3F FF TOBR2 JSR RESTORE  RESTORE 6502 REG CONTENTS
F6CC: 6C 1E 00 TOBR2 JMP (R15L)   RETURN TO 6502 CODE VIA PC
F6CF: E1 1F     SETZ LDA (R15L),Y HIGH-ORDER BYTE OF CONSTANT

```

F6D1:	95 01		STA	ROH,X	
F6D3:	88		DFY		
F6D4:	B1 1E		LDA	(R15L),Y	LOW-ORDER BYTE OF CONSTANT
F6D6:	95 00		STA	ROL,X	
F6D8:	98		TYA		Y-REG CONTAINS 1
F6D9:	38		SEC		
F6DA:	65 1E		ADC	R15L	ADD 2 TO PC
F6DC:	85 1E		STA	R15L	
F6DE:	90 02		BCC	SET2	
F6E0:	E6 1F		INC	R15H	
F6E2:	60	SET2	RTS		
F6E3:	02	OPTBL	DFB	SET-1	(1X)
F6E4:	F9	RRTRBL	DFE	RTN-1	(0)
F6E5:	04		DFH	LD-1	(2X)
F6E6:	9D		DFB	CR-1	(1)
F6E7:	0D		DFB	ST-1	(3X)
F6E8:	9E		DFB	RMC-1	(2)
F6E9:	25		DFB	LDAT-1	(4X)
F6EA:	AF		DFB	BC-1	(3)
F6EB:	16		DFB	STAT-1	(5X)
F6EC:	B2		DFB	BP-1	(4)
F6ED:	47		DFB	LDDAT-1	(6X)
F6EE:	B9		DFB	BM-1	(5)
F6EF:	51		DFB	STDAT-1	(7X)
F6F0:	C0		DFB	RZ-1	(6)
F6F1:	2F		DFB	POP-1	(8X)
F6F2:	C9		DFB	RNZ-1	(7)
F6F3:	58		DFB	STPAT-1	(9X)
F6F4:	D2		DFB	BM1-1	(8)
F6F5:	85		DFB	ADD-1	(AX)
F6F6:	DD		DFB	BNM1-1	(9)
F6F7:	6E		DFB	SU3-1	(BX)
F6F8:	05		DFE	RK-1	(A)
F6F9:	33		DFE	PCPD-1	(CX)
F6FA:	E8		DFB	RS-1	(8)
F6FB:	70		DFB	CPR-1	(DX)
F6FC:	93		DFB	SS-1	(C)
F6FD:	1E		DFB	INR-1	(FX)
F6FE:	E7		DFB	NUL-1	(D)
F6FF:	65		DFB	DCR-1	(FX)
F700:	E7		DFB	NUL-1	(E)
F701:	E7		DFB	NUL-1	(UNUSED)
F702:	E7		DFB	NUL-1	(F)
F703:	10 CA	SET	BPL	SETZ	ALWAYS TAKEN
F705:	B5 00	LD BK	LDA EQU	ROL,X *-1	
F707:	85 00		STA	ROL	
F709:	B5 01		LDA	ROH,X	MOVE RX TO RO
F70B:	85 01		STA	ROH	
F70D:	60		RTS		
F70E:	A5 00	ST	LDA	ROL	
F710:	95 00		STA	ROL,X	MOVE RO TO RX
F712:	A5 01		LDA	ROH	
F714:	95 01		STA	ROH,X	
F716:	60		RTS		
F717:	A5 00	STAT	LDA	ROL	
F719:	81 00	STAT2	STA	(ROL,X)	STORE BYTE INDIRECT
F71B:	A0 00		LDY	#S0	
F71D:	84 1D	STAT3	STY	R14H	INDICATE RO IS RESULT REG
F71F:	F6 00	INR	INC	ROL,X	
F721:	D0 02		BNE	INR2	INCR RX
F723:	F6 01		INC	ROH,X	
F725:	60	INR2	RTS		
F726:	A1 00	LDAT	LDA	(ROL,X)	LOAD INDIRECT (RX)
F728:	85 00		STA	ROL	TO RO
F72A:	A0 00		LDY	#S0	
F72C:	84 01		STY	ROH	ZERO HIGH-ORDER PO BYTE
F72E:	F0 ED		BEQ	STAT3	ALWAYS TAKEN
F730:	A0 00	POP	LDY	#S0	HIGH ORDER BYTE = 0
F732:	F0 06		BEQ	POP2	ALWAYS TAKEN
F734:	20 66	F7 POPD	JSR	DCR	DECR RX
F737:	A1 00		LDA	(ROL,X)	POP HIGH-ORDER BYTE @RX
F739:	A8		TAY		SAVE IN Y-REG
F73A:	20 66	F7 POP2	JSR	DCP	DECR RX
F73D:	A1 00		LDA	(ROL,X)	LOW-ORDER BYTE
F73F:	85 00		STA	ROL	TO RO
F741:	84 01		STY	ROH	
F743:	A0 00	POP3	LDY	#S0	INDICATE RO AS LAST RSLT REG
F745:	84 1D		STY	R14H	
F747:	60		RTS		
F748:	20 26	F7 LDDAT	JSR	LDAT	LOW-ORDER BYTE TO RO, INCR RX
F74B:	A1 00		LDA	(ROL,X)	HIGH-ORDER BYTE TO RO
F74D:	85 01		STA	ROH	
F74F:	4C 1F	F7	JMP	INR	INCR RX
F752:	20 17	F7 STDAT	JSR	STAT	STORE INDIRECT LOW-ORDER

F755: A5 01		LDA R0H	BYTE AND INCR RX. THEN
F757: 81 00		STA (R0L,X)	STORE HIGH-ORDER BYTE.
F759: 4C 1F F7		JMP INR	INCR RX AND RETURN
F75C: 20 66 F7	STPAT	JSR DCF	DECR RX
F75F: A5 00		LDA R0L	
F761: 81 00		STA (R0L,X)	STORE R0 LOW BYTE @RX
F763: 4C 43 F7		JMP POP3	INDICATE R0 AS LAST RSLT REG
F766: B5 00	DCR	LDA R0L,X	
F768: D0 02		BNE DCR2	DECR PX
F76A: D6 01		DEC R0H,X	
F76C: D6 00	DCR2	DEC R0L,X	
F76E: 60		RTS	
F76F: A0 00	SUB	LDY #S0	RESULT TO R0
F771: 38	CPR	SEC	NOTE Y-REG = 13*2 FOR CPR
F772: A5 00		LDA R0L	
F774: F5 00		SBC R0L,X	
F776: 99 00 00		STA R0L,Y	R0-RX TO RY
F779: A5 01		LDA R0H	
F77B: F5 01		SBC R0H,X	
F77D: 99 01 00	SUB2	STA R0H,Y	
F780: 98		TYA	LAST RESULT REG*2
F781: 69 00		ADC #S0	CARRY TO LSB
F783: 85 1D		STA R14H	
F785: 60		RTS	
F786: A5 00	ADD	LDA R0L	
F788: 75 00		ADC R0L,X	
F78A: 85 00		STA R0L	R0+RX TO R0
F78C: A5 01		LDA R0H	
F78E: 75 01		ADC R0H,X	
F790: A0 00		LDY #S0	R0 FOR RESULT
F792: F0 E9		BEQ SUB2	FINISH ADD
F794: A5 1E	BS	LDA R15L	NOTE X-REG IS 12*2!
F796: 20 19 F7		JSR STAT2	PUSH LOW PC BYTE VIA R12
F799: A5 1F		LDA R15H	
F79B: 20 19 F7		JSR STAT2	PUSH HIGH-ORDER PC BYTE
F79E: 18	BR	CLC	
F79F: B0 0E	BNC	BCS BNC2	NO CARRY TEST
F7A1: B1 1E	BR1	LDA (R15L),Y	DISPLACEMENT BYTE
F7A3: 10 01		BPL BR2	
F7A5: 88		DEY	
F7A6: 65 1E	BR2	ADC R15L	ADD TO PC
F7A8: 85 1E		STA R15L	
F7AA: 98		TYA	
F7AB: 65 1F		ADC R15H	
F7AD: 85 1F		STA R15H	
F7AF: 60	BNC2	RTS	
F7B0: B0 EC	BC	BCS BR	
F7B2: 60		RTS	
F7B3: 0A	BP	ASL A	DOUBLE RESULT-REG INDEX
F7B4: AA		TAX	TO X-REG FOR INDEXING
F7B5: B5 01		LDA R0H,X	TEST FOR PLUS
F7B7: 10 E8		BPL BR1	BRANCH IF SO
F7B9: 60		PTS	
F7BA: 0A	BM	ASL A	DOUBLE RESULT-REG INDEX
F7B2: AA		TAX	
F7BC: B5 01		LDA R0H,X	TEST FOR MINUS
F7BE: 30 E1		BMI BR1	
F7C0: 60		RTS	
F7C1: 0A	BZ	ASL A	DOUBLE RESULT-REG INDEX
F7C2: AA		TAX	
F7C3: B5 00		LDA R0L,X	TEST FOR ZERO
F7C5: 15 01		ORA R0H,X	(BOTH BYTES)
F7C7: F0 D8		BEQ BR1	BRANCH IF SO
F7C9: 60		PTS	
F7CA: 0A	BNZ	ASL A	DOUBLE RESULT-REG INDEX
F7CB: AA		TAX	
F7CC: B5 00		LDA R0L,X	TEST FOR NONZERO
F7CE: 15 01		ORA R0H,X	(BOTH BYTES)
F7D0: D0 CF		BNE BR1	BRANCH IF SO
F7D2: 60		RTS	
F7D3: 0A	BM1	ASL A	DOUBLE RESULT-REG INDEX
F7D4: AA		TAX	
F7D5: B5 00		LDA R0L,X	CHECK BOTH BYTES
F7D7: 35 01		AND R0H,X	FOR \$FF (MINUS 1)
F7D9: 49 FF		EOR #\$FF	
F7DB: F0 C4		BEQ BR1	BRANCH IF SO
F7DD: 60		RTS	
F7DE: 0A	BNM1	ASL A	DOUBLE RESULT-REG INDEX
F7DF: AA		TAX	
F7E0: B5 00		LDA R0L,X	CHECK BOTH BYTES FOR NO \$FF
F7E2: 35 01		AND R0H,X	
F7E4: 49 FF		EOR #\$FF	
F7E6: D0 B9		BNE BR1	BRANCH IF NOT MINUS 1
F7E8: 60	NUL	RTS	
F7E9: A2 18	RS	LDX #\$18	12*2 FOR R12 AS STK POINTER

F7EB:	20	66	F7	JSR	DCR	DECR STACK POINTER
F7EE:	A1	00		LDA	(R0L,X)	POP HIGH RETURN ADR TO PC
F7F0:	85	1F		STA	R15H	
F7F2:	20	66	F7	JSR	DCR	SAME FOR LOW-ORDER BYTE
F7F5:	A1	00		LDA	(R0L,X)	
F7F7:	85	1E		STA	R15L	
F7F9:	60			RTS		
F7FA:	4C	C7	F6	JMP	RTNZ	

# 6502 MICROPROCESSOR INSTRUCTIONS

<b>ADC</b>	Add Memory to Accumulator with Carry	<b>LDA</b>	Load Accumulator with Memory
<b>AND</b>	"AND" Memory with Accumulator	<b>LDX</b>	Load Index X with Memory
<b>ASL</b>	Shift Left One Bit (Memory or Accumulator)	<b>LDY</b>	Load Index Y with Memory
<b>BCC</b>	Branch on Carry Clear	<b>LSR</b>	Shift Right one Bit (Memory or Accumulator)
<b>BCS</b>	Branch on Carry Set	<b>NOP</b>	No Operation
<b>BEQ</b>	Branch on Result Zero	<b>ORA</b>	"OR" Memory with Accumulator
<b>BIT</b>	Test Bits in Memory with Accumulator	<b>PHA</b>	Push Accumulator on Stack
<b>BMI</b>	Branch on Result Minus	<b>PHP</b>	Push Processor Status on Stack
<b>BNE</b>	Branch on Result not Zero	<b>PLA</b>	Pull Accumulator from Stack
<b>BPL</b>	Branch on Result Plus	<b>PLP</b>	Pull Processor Status from Stack
<b>BRK</b>	Force Break	<b>ROL</b>	Rotate One Bit Left (Memory or Accumulator)
<b>BVC</b>	Branch on Overflow Clear	<b>ROR</b>	Rotate One Bit Right (Memory or Accumulator)
<b>BVS</b>	Branch on Overflow Set	<b>RTI</b>	Return from Interrupt
<b>CLC</b>	Clear Carry Flag	<b>RTS</b>	Return from Subroutine
<b>CLD</b>	Clear Decimal Mode	<b>SBC</b>	Subtract Memory from Accumulator with Borrow
<b>CLI</b>	Clear Interrupt Disable Bit	<b>SEC</b>	Set Carry Flag
<b>CLV</b>	Clear Overflow Flag	<b>SED</b>	Set Decimal Mode
<b>CMP</b>	Compare Memory and Accumulator	<b>SEI</b>	Set Interrupt Disable Status
<b>CPX</b>	Compare Memory and Index X	<b>STA</b>	Store Accumulator in Memory
<b>CPY</b>	Compare Memory and Index Y	<b>STX</b>	Store Index X in Memory
<b>DEC</b>	Decrement Memory by One	<b>STY</b>	Store Index Y in Memory
<b>DEX</b>	Decrement Index X by One	<b>TAX</b>	Transfer Accumulator to Index X
<b>DEY</b>	Decrement Index Y by One	<b>TAY</b>	Transfer Accumulator to Index Y
<b>EOR</b>	"Exclusive-Or" Memory with Accumulator	<b>TSX</b>	Transfer Stack Pointer to Index X
<b>INC</b>	Increment Memory by One	<b>TXA</b>	Transfer Index X to Accumulator
<b>INX</b>	Increment Index X by One	<b>TXS</b>	Transfer Index X to Stack Pointer
<b>INY</b>	increment Index Y by One	<b>TYA</b>	Transfer Index Y to Accumulator
<b>JMP</b>	Jump to New Location		
<b>JSR</b>	Jump to New Location Saving Return Address		

# THE FOLLOWING NOTATION APPLIES TO THIS SUMMARY:

A	Accumulator
X, Y	Index Registers
M	Memory
C	Borrow
P	Processor Status Register
S	Stack Pointer
✓	Change
—	No Change
+	Add
∧	Logical AND
-	Subtract
⊕	Logical Exclusive Or
↑	Transfer From Stack
↓	Transfer To Stack
→	Transfer To
←	Transfer To
V	Logical OR
PC	Program Counter
PCH	Program Counter High
PCL	Program Counter Low
OPER	Operand
#	Immediate Addressing Mode

FIGURE 1. ASL-SHIFT LEFT ONE BIT OPERATION

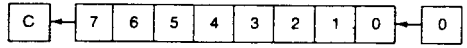

FIGURE 2. ROTATE ONE BIT LEFT (MEMORY OR ACCUMULATOR)

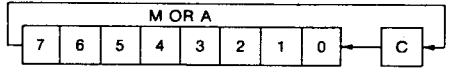
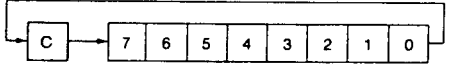

FIGURE 3.



NOTE 1: BIT — TEST BITS

Bit 6 and 7 are transferred to the status register. If the result of  $A \wedge M$  is zero then  $Z=1$ , otherwise  $Z=0$ .

## PROGRAMMING MODEL

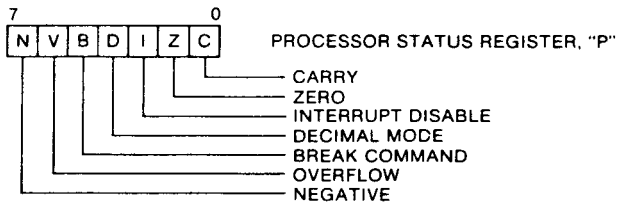
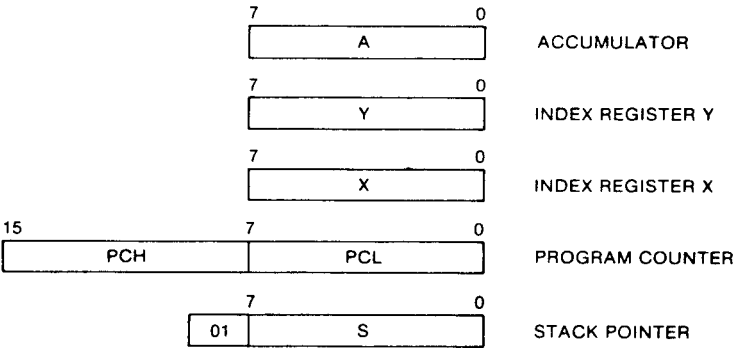



# INSTRUCTION CODES

Name Description	Operation	Addressing Mode	Assembly Language Form	HEX OP Code	No. Bytes	"P" Status Reg. M Z C I D V
<b>BVS</b> Branch on overflow set	Branch on V=1	Relative	BVS Oper	70	2	---0---
<b>CLC</b> Clear carry flag	0 → C	Implied	CLC	18	1	---0---
<b>CLD</b> Clear decimal mode	0 → D	Implied	CLD	D8	1	---0---
<b>CLI</b>	0 → I	Implied	CLI	58	1	---0---
<b>CLV</b> Clear overflow flag	0 → V	Implied	CLV	B8	1	0-----
<b>CMP</b> Compare memory and accumulator	A — M	Immediate Zero Page Zero Page, X Absolute Absolute, X Absolute, Y Absolute, Y (Indirect, X) (Indirect, Y)	CMP #Oper CMP Oper CMP Oper, X CMP Oper CMP Oper, X CMP Oper, Y CMP Oper, X CMP (Oper, X) CMP (Oper), Y	C9 C5 D5 CD DD D9 C1 D1	2 2 2 3 3 3 2 2	✓✓✓----
<b>CPX</b> Compare memory and index X	X — M	Immediate Zero Page Absolute	CPX #Oper CPX Oper CPX Oper	E0 E4 EC	2 2 3	✓✓✓----
<b>CPY</b> Compare memory and index Y	Y — M	Immediate Zero Page Absolute	CPY #Oper CPY Oper CPY Oper	C0 C4 CC	2 2 3	✓✓✓----
<b>DEC</b> Decrement memory by one	M — 1 → M	Zero Page Zero Page, X Absolute Absolute, X	DEC Oper DEC Oper, X DEC Oper DEC Oper, X	C6 D6 CE DE	2 2 3 3	✓✓✓----
<b>DEX</b> Decrement index X by one	X — 1 → X	Implied	DEX	CA	1	✓✓✓----
<b>DEY</b> Decrement index Y by one	Y — 1 → Y	Implied	DEY	88	1	✓✓✓----

Name Description	Operation	Addressing Mode	Assembly Language Form	HEX OP Code	No. Bytes	"P" Status Reg. M Z C I D V
<b>ADC</b> Add memory to accumulator with carry	A-M-C → A+C	Immediate Zero Page, X Absolute Absolute, X Absolute, Y Absolute, Y (Indirect, X) (Indirect, Y)	ADC #Oper ADC Oper ADC Oper, X ADC Oper ADC Oper, X ADC Oper, Y ADC (Oper, X) ADC (Oper), Y	69 65 75 6D 7D 79 61 71	2 2 2 3 3 3 2 2	✓✓✓✓✓
<b>AND</b> "AND" memory with accumulator	A & M → A	Immediate Zero Page Zero Page, X Absolute Absolute, X Absolute, Y Absolute, Y (Indirect, X) (Indirect, Y)	AND #Oper AND Oper AND Oper, X AND Oper AND Oper, X AND Oper, Y AND (Oper, X) AND (Oper), Y	29 25 35 2D 3D 39 21 31	2 2 2 3 3 3 2 2	✓✓✓✓✓
<b>ASL</b> Shift left one bit (Memory or Accumulator)	(See Figure 1)	Accumulator Zero Page Zero Page, X Absolute Absolute, X	ASL A ASL Oper ASL Oper, X ASL Oper ASL Oper, X	0A 06 16 0E 1E	1 2 2 3 3	✓✓✓✓✓
<b>BCC</b> Branch on carry clear	Branch on C=0	Relative	BCC Oper	90	2	-----
<b>BCS</b> Branch on carry set	Branch on C=1	Relative	BCS Oper	B0	2	-----
<b>BEQ</b> Branch on result zero	Branch on Z=1	Relative	BEQ Oper	F0	2	-----
<b>BIT</b> Test bits in memory with accumulator	A & M, M <sub>7</sub> → N, M <sub>6</sub> → V	Zero Page Absolute	BIT* Oper BIT* Oper	24 2C	2 3	M <sub>7</sub> ✓✓---M <sub>6</sub>
<b>BMI</b> Branch on result minus	Branch on N=1	Relative	BMI Oper	30	2	-----
<b>BNE</b> Branch on result not zero	Branch on Z=0	Relative	BNE Oper	D0	2	-----
<b>BPL</b> Branch on result plus	Branch on N=0	Relative	BPL Oper	10	2	-----
<b>BRK</b> Force Break	Forced Interrupt PC+2 ↑ P ↑	Implied	BRK*	00	1	---1---
<b>BVC</b> Branch on overflow clear	Branch on V=0	Relative	BVC Oper	50	2	-----

NOTE 1: \* and \* are transferred to the status register. If the result of A, V, M is 1, then PC+1, otherwise Z=0.

NOTE 2: A BRK command cannot be masked by setting.



# INSTRUCTION CODES

Name Description	Operation	Addressing Mode	Assembly Language Form	HEX OP Code	No. Bytes	"P" Status Reg. N Z C I O V
<b>RTI</b> Return from interrupt	P ← PC ↑	Implied	RTI	40	1	From Stack
<b>RTS</b> Return from subroutine	PC ← PC + 1 → PC	Implied	RTS		1	-----
<b>SBC</b> Subtract memory from accumulator with borrow	A - M - C → A	Immediate Zero Page Zero Page,X Absolute Absolute,X Absolute,Y (Indirect,X) (Indirect),Y	SBC #Oper SBC Oper SBC Oper,X SBC Oper SBC Oper,X SBC Oper,Y SBC (Oper,X) SBC (Oper),Y	E9 E5 F5 ED FD F9 E1 F1	2 2 2 3 3 3 2 2	✓✓✓✓✓
<b>SEC</b> Set carry flag	1 → C	Implied	SEC	38	1	---1---
<b>SED</b> Set decimal mode	1 → D	Implied	SED	F8	1	-----1--
<b>SEI</b> Set interrupt disable status	1 → I	Implied	SEI	78	1	----1---
<b>STA</b> Store accumulator in memory	A → M	Zero Page Zero Page,X Absolute Absolute,X Absolute,Y (Indirect,X) (Indirect),Y	STA Oper STA Oper,X STA Oper STA Oper,X STA Oper,Y STA (Oper,X) STA (Oper),Y	85 95 8D 9D 81 81 91	2 2 3 3 3 2 2	-----
<b>STX</b> Store index X in memory	X → M	Zero Page Zero Page,Y Absolute	STX Oper STX Oper,Y STX Oper	86 96 8E	2 2 3	-----
<b>STY</b> Store index Y in memory	Y → M	Zero Page Zero Page,X Absolute	STY Oper STY Oper,X STY Oper	84 94 8C	2 2 3	-----
<b>TAX</b> Transfer accumulator to index X	A → X	Implied	TAX	AA	1	✓✓-----
<b>TAY</b> Transfer accumulator to index Y	A → Y	Implied	TAY	AB	1	✓✓-----
<b>TSX</b> Transfer stack pointer to index X	S → X	Implied	TSX	BA	1	✓✓-----

Name Description	Operation	Addressing Mode	Assembly Language Form	HEX OP Code	No. Bytes	"P" Status Reg. N Z C I O V
<b>TXA</b> Transfer index X to accumulator	X → A	Implied	TXA	8A	1	✓✓-----
<b>TXS</b> Transfer index X to stack pointer	X → S	Implied	TXS	9A	1	-----
<b>TYA</b> Transfer index Y to accumulator	Y → A	Implied	TYA	98	1	✓✓-----



# APPLE II HARDWARE

1. Getting Started with Your APPLE II Board
2. APPLE II Switching Power Supply
3. Interfacing with the Home TV
4. Simple Serial Output
5. Interfacing the APPLE —  
    Signals, Loading, Pin Connections
6. Memory —  
    Options, Expansion, Map, Address
7. System Timing
8. Schematics

# GETTING STARTED WITH YOUR APPLE II BOARD

## INTRODUCTION

### ITEMS YOU WILL NEED:

Your APPLE II board comes completely assembled and thoroughly tested. You should have received the following:

- a. 1 ea. APPLE II P.C. Board complete with specified RAM memory.
- b. 1 ea. d.c. power connector with cable.
- c. 1 ea. 2" speaker with cable.
- d. 1 ea. Preliminary Manual
- e. 1 ea. Demonstration cassette tapes. (For 4K: 1 cassette (2 programs); 16K or greater: 3 cassettes.
- f. 2 ea. 16 pin headers plugged into locations A7 and J14.

In addition you will need:

- g. A color TV set (or B & W) equipped with a direct video input connector for best performance or a commercially available RF modulator such as a "Pixi-verter"<sup>tm</sup>. Higher channel (7-13) modulators generally provide better system performance than lower channel modulators (2-6).
- h. The following power supplies (NOTE: current ratings do not include any capacity for peripheral boards.):
  1. +12 Volts with the following current capacity:
    - a. For 4K or 16K systems - 350mA.
    - b. For 8K, 20K or 32K - 550mA.
    - c. For 12K, 24K, 36K or 48K - 850mA.
  2. +5 Volts at 1.6 amps
  3. -5 Volts at 10mA.
  4. OPTIONAL: If -12 Volts is required by your keyboard. (If using an APPLE II supplied keyboard, you will need -12V at 50mA.)

- i. An audio cassette recorder such as a Panasonic model RQ-309 DS which is used to load and save programs.
- j. An ASCII encoded keyboard equipped with a "reset" switch.
- k. Cable for the following:
  - 1. Keyboard to APPLE II P.C.B.
  - 2. Video out 75 ohm cable to TV or modulator
  - 3. Cassette to APPLE II P.C.B. (1 or 2)

Optionally you may desire:

- l. Game paddles or pots with cables to APPLE II Game I/O connector. (Several demo programs use PDL(0) and "Pong" also uses PDL(1).
- m. Case to hold all the above

### Final Assembly Steps

- 1. Using detailed information on pin functions in hardware section of manual, connect power supplies to d.c. cable assembly. Use both ground wires to minimize resistance. With cable assembly disconnected from APPLE II mother board, turn on power supplies and verify voltages on connector pins. Improper supply connections such as reverse polarity can severely damage your APPLE II.
- 2. Connect keyboard to APPLE II by unplugging leader in location A7 and wiring keyboard cable to it, then plug back into APPLE II P.C.B.
- 3. Plug in speaker cable.
- 4. Optionally connect one or two game paddles using leader supplied in socket located at J14.
- 5. Connect video cable.
- 6. Connect cable from cassette monitor output to APPLE II cassette input.
- 7. Check to see that APPLE II board is not contacting any conducting surface.
- 8. With power supplies turned off, plug in power connector to mother board then recheck all cableing.

## POWER UP

1. Turn power on. If power supplies overload, immediately turn off and recheck power cable wiring. Verify operating supply voltages are within  $\pm 3\%$  of nominal value.
2. You should now have random video display. If not check video level pot on mother board, full clockwise is maximum video output. Also check video cables for opens and shorts. Check modulator if you are using one.
3. Press reset button. Speaker should beep and a "\*" prompt character with a blinking cursor should appear in lower left on screen.
4. Press "esc" button, release and type a "@" (shift-P) to clear screen. You may now try "Monitor" commands if you wish. See details in "Monitor" software section.

## RUNNING BASIC

1. Turn power on; press reset button; type "control B" and press return button. A ">" prompt character should appear on screen indicating that you are now in BASIC.
2. Load one of the supplied demonstration cassettes into recorder. Set recorder level to approximately 5 and start recorder. Type "LOAD" and return. First beep indicates that APPLE II has found beginning of program; second indicates end of program followed by ">" character on screen. If error occurs on loading, try a different demo tape or try changing cassette volume level.
3. Type RUN and carriage return to execute demonstration program. Listings of these are included in the last section of this manual.



Switching power supplies generally have both advantages and peculiarities not generally found in conventional power supplies. The Apple II user is urged to review this section.

Your Apple II is equipped with an AC line voltage filter and a three wire AC line cord. It is important to make sure that the third wire is returned to earth ground. Use a continuity checker or ohmmeter to ensure that the third wire is actually returned to earth. Continuity should be checked for between the power supply case and an available water pipe for example. The line filter, which is of a type approved by domestic (U.L. CSA) and international (VDE) agencies must be returned to earth to function properly and to avoid potential shock hazards.

The APPLE II power supply is of the "flyback" switching type. In this system, the AC line is rectified directly, "chopped up" by a high frequency oscillator and coupled through a small transformer to the diodes, filters, etc., and results in four low voltage DC supplies to run APPLE II. The transformer isolates the DC supplies from the line and is provided with several shields to prevent "hash" from being coupled into the logic or peripherals. In the "flyback" system, the energy transferred through from the AC line side to DC supply side is stored in the transformer's inductance on one-half of the operating cycle, then transferred to the output filter capacitors on the second half of the operating cycle. Similar systems are used in TV sets to provide horizontal deflection and the high voltages to run the CRT.

Regulation of the DC voltages is accomplished by controlling the frequency at which the converter operates; the greater the output power needed, the lower the frequency of the converter. If the converter is overloaded, the operating frequency will drop into the audible range with squeals and squawks warning the user that something is wrong.

All DC outputs are regulated at the same time and one of the four outputs (the +5 volt supply) is compared to a reference voltage with the difference error fed to a feedback loop to assist the oscillator in running at the needed frequency. Since all DC outputs are regulated together, their voltages will reflect to some extent unequal loadings.

For example; if the +5 supply is loaded very heavily, then all other supply voltages will increase in voltage slightly; conversely, very light loading on the +5 supply and heavy loading on the +12 supply will cause both it and the others to sag lightly. If precision reference voltages are needed for peripheral applications, they should be provided for in the peripheral design.

In general, the APPLE II design is conservative with respect to component ratings and operating temperatures. An over-voltage crowbar shutdown system and an auxiliary control feedback loop are provided to ensure that even very unlikely failure modes will not cause damage to the APPLE II computer system. The over-voltage protection references to the DC output voltages only. The AC line voltage input must be within the specified limits, i.e., 107V to 132V.

Under no circumstances, should more than 140 VAC be applied to the input of the power supply. Permanent damage will result.

Since the output voltages are controlled by changing the operating frequency of the converter, and since that frequency has an upper limit determined by the switching speed of power transistors, there then must be a minimum load on the supply; the Apple II board with minimum memory (4K) is well above that minimum load. However, with the board disconnected, there is no load on the supply, and the internal over-voltage protection circuitry causes the supply to turn off. A 9 watt load distributed roughly 50-50 between the +5 and +12 supply is the nominal minimum load.

Nominal load current ratios are: The +12V supply load is  $\frac{1}{2}$  that of the +5V.  
The - 5V supply load is  $\frac{1}{10}$  that of the +5V.  
The -12V supply load is  $\frac{1}{10}$  that of the +5V.

The supply voltages are  $+5.0 \pm 0.15$  volts,  $+11.8 \pm 0.5$  volts,  $-12.0 \pm 1V$ ,  $-5.2 \pm 0.5$  volts. The tolerances are greatly reduced when the loads are close to nominal.

The Apple II power supply will power the Apple II board and all present and forthcoming plug-in cards, we recommend the use of low power TTL, CMOS, etc. so that the total power drawn is within the thermal limits of the entire system. In particular, the user should keep the total power drawn by any one card to less than 1.5 watts, and the total current drawn by all the cards together within the following limits:

+ 12V - use no more than 250 mA  
+ 5V - use no more than 500 mA  
- 5V - use no more than 200 mA  
- 12V - use no more than 200 mA

The power supply is allowed to run indefinitely under short circuit or open circuit conditions.

CAUTION: There are dangerous high voltages inside the power supply case. Much of the internal circuitry is NOT isolated from the power line, and special equipment is needed for service. NO REPAIR BY THE USER IS ALLOWED.

## NOTES ON INTERFACING WITH THE HOME TV

Accessories are available to aid the user in connecting the Apple II system to a home color TV with a minimum of trouble. These units are called "RF Modulators" and they generate a radio frequency signal corresponding to the carrier of one or two of the lower VHF television bands; 61.25 MHz (channel 3) or 67.25 MHz (channel 4). This RF signal is then modulated with the composite video signal generated by the Apple II.

Users report success with the following RF modulators:

the "PixieVerter" (a kit)  
ATV Research  
13th and Broadway  
Dakota City, Nebraska 68731

the "TV-1" (a kit)  
UHF Associates  
6037 Haviland Ave.  
Whittier, CA 90601

the "Sup-r-Mod" by (assembled & tested)  
M&R Enterprises  
P.O. Box 1011  
Sunnyvale, CA 94088

the RF Modulator (a P.C. board)  
Electronics Systems  
P.O. Box 212  
Burlingame, CA 94010

Most of the above are available through local computer stores.

The Apple II owner who wishes to use one of these RF Modulators should read the following notes carefully.

All these modulators have a free running transistor oscillator. The M&R Enterprises unit is pre-tuned to Channel 4. The PixieVerter and the TV-1 have tuning by means of a jumper on the P.C. board and a small trimmer capacitor. All these units have a residual FM which may cause trouble if the TV set in use has a IF pass band with excessive ripple. The unit from M&R has the least residual FM.

All the units except the M&R unit are kits to be built and tuned by the customer. All the kits are incomplete to some extent. The unit from Electronics Systems is just a printed circuit board with assembly instructions. The kits from UHF Associates and ATV do not have an RF cable or a shielded box or a balun transformer, or an antenna switch. The M&R unit is complete.

Some cautions are in order. The Apple II, by virtue of its color graphics capability, operates the TV set in a linear mode rather than the 100% contrast mode satisfactory for displaying text. For this reason, radio frequency interference (RFI) generated by a computer (or peripherals) will beat with the

carrier of the RF modulator to produce faint spurious background patterns (called "worms") This RFI "trash" must be of quite a low level if worms are to be prevented. In fact, these spurious beats must be 40 to 50db below the signal level to reduce worms to an acceptable level. When it is remembered that only 2 to 6 mV (across 300 $\Omega$ ) is presented to the VHF input of the TV set, then stray RFI getting into the TV must be less than 50 $\mu$ V to obtain a clean picture. Therefore we recommend that a good, co-ax cable be used to carry the signal from any modulator to the TV set, such as RG/59u (with copper shield), Belden #8241 or an equivalent miniature type such as Belden #8218. We also recommend that the RF modulator be enclosed in a tight metal box (an unpainted die cast aluminum box such as Pomona #2428). Even with these precautions, some trouble may be encountered with worms, and can be greatly helped by threading the coax cable connecting the modulator to the TV set repeatedly through a Ferrite toroid core. Apple Computer supplies these cores in a kit, along with a 4 circuit connector/cable assembly to match the auxilliary video connector found on the Apple II board. This kit has order number A2M010X. The M&R "Sup-r-Mod" is supplied with a coax cable and toroids.

Any computer containing fast switching logic and high frequency clocks will radiate some radio frequency energy. Apple II is equipped with a good line filter and many other precautions have been taken to minimize radiated energy. The user is urged not to connect "antennas" to this computer; wires strung about carrying clocks and/data will act as antennas, and subsequent radiated energy may prove to be a nuisance.

Another caution concerns possible long term effects on the TV picture tube. Most home TV sets have "Brightness" and "Contrast" controls with a very wide range of adjustment. When an un-changing picture is displayed with high brightness for a long period, a faint discoloration of the TV CRT may occur as an inverse pattern observable with the TV set turned off. This condition may be avoided by keeping the "Brightness" turned down slightly and "Contrast" moderate.

## A SIMPLE SERIAL OUTPUT

The Apple II is equipped with a 16 pin DIP socket most frequently used to connect potentiometers, switches, etc. to the computer for paddle control and other game applications. This socket, located at J-14, has outputs available as well. With an appropriate machine language program, these output lines may be used to serialize data in a format suitable for a teletype. A suitable interface circuit must be built since the outputs are merely LSTTL and won't run a teletype without help. Several interface circuits are discussed below and the user may pick the one best suited to his needs.

### The ASR - 33 Teletype

The ASR - 33 Teletype of recent vintage has a transistor circuit to drive its solenoids. This circuit is quite easy to interface to, since it is provided with its own power supply. (Figure 1a) It can be set up for a 20mA current loop and interfaced as follows (whether or not the teletype is strapped for full duplex or half duplex operation):

- a) The yellow wire and purple wire should both go to terminal 9 of Terminal Strip X. If the purple wire is going to terminal 8, then remove it and relocate it at terminal 9. This is necessary to change from the 60mA current loop to the 20mA current loop.
- b) Above Terminal Strip X is a connector socket identified as "2". Pin 8 is the input line + or high; Pin 7 is the input line - or low. This connector mates with a Molex receptacle model 1375 #03-09-2151 or #03-09-2153. Recommended terminals are Molex #02-09-2136. An alternate connection method is via spade lugs to Terminal Strip X, terminal 7 (the + input line) and 6 (the - input line).
- c) The following circuit can be built on a 16 pin DIP component carrier and then plugged into the Apple's 16 pin socket found at J-14: (The junction of the 3.3k resistor and the transistor base lead is floating). Pins 16 and 9 are used as tie points as they are unconnected on the Apple board. (Figure 1a).

## The "RS - 232 Interface"

For this interface to be legitimate, it is necessary to twice invert the signal appearing at J-14 pin 15 and have it swing more than 5 volts both above and below ground. The following circuit does that but requires that both +12 and -12 supplies be used. (Figure 2) Snipping off pins on the DIP-component carrier will allow the spare terminals to be used for tie points. The output ground connects to pin 7 of the DB-25 connector. The signal output connects to pin 3 of the DB-25 connector. The "protective" ground wire normally found on pin 1 of the DB-25 connector may be connected to the Apple's base plate if desired. Placing a #4 lug under one of the four power supply mounting screws is perhaps the simplest method. The +12 volt supply is easily found on the auxiliary Video connector (see Figure S-11 or Figure 7 of the manual). The -12 volt supply may be found at pin 33 of the peripheral connectors (see Figure 4) or at the power supply connector (see Figure 5 of the manual).

## A Serial Out Machine Center Language Program

Once the appropriate circuit has been selected and constructed a machine language program is needed to drive the circuit. Figure 3 lists such a teletype output machine language routine. It can be used in conjunction with an Integer BASIC program that doesn't require page \$300 hex of memory. This program resides in memory from \$370 to \$3E9. Columns three and four of the listing show the op-code used. To enter this program into the Apple II the following procedure is followed:

### Entering Machine Language Program

1. Power up Apple II
2. Depress and release the "RESET" key. An asterick and flashing cursor should appear on the left hand side of the screen below the random text matrix.
3. Now type in the data from columns one, two and three for each line from \$370 to 03E9. For example, type in "370: A9 82" and then depress and release the "RETURN" key. Then repeat this procedure for the data at \$372 and on until you complete entering the program.

### Executing this Program

1. From BASIC a CALL 880 (\$370) will start the execution of this program. It will use the teletype or suitable 80 column printer as the primary output device.

2. PR#0 will inactivate the printer transferring control back to the Video monitor as the primary output device.
3. In Monitor mode \$370G activates the printer and hitting the "RESET" key exits the program.

### Saving the Machine Language Program

After the machine language program has been entered and checked for accuracy it should, for convenience, be saved on tape - that is unless you prefer to enter it by keyboard every time you want to use it.

The way it is saved is as follows:

1. Insert a blank program cassette into the tape recorder and rewind it.
2. Hit the "RESET" key. The system should move into Monitor mode. An asterick "\*" and flashing cursor should appear on the left-hand side of the screen.
3. Type in "370.03E9W 370.03E9W".
4. Start the tape recorder in record mode and depress the "RETURN" key.
5. When the program has been written to tape, the asterick and flashing cursor will reappear.

### The Program

After entering, checking and saving the program perform the following procedure to get a feeling of how the program is used:

1. B<sup>C</sup> (control B) into BASIC
2. Turn the teletype (printer on)
3. Type in the following

```
10 CALL 880
15 PRINT "ABCD...XYZ01123456789"
20 PR#0
25 END
```
4. Type in RUN and hit the "RETURN" key. The text in line 15 should be printed on the teletype and control is returned to the keyboard and Video monitor.

Line 10 activates the teletype machine routine and all "PRINT" statements following it will be printed to the teletype until a PR#0 statement is encountered. Then the text in line 15 will appear on the teletype's output. Line 20 deactivates the printer and the program ends on line 25.

### Conclusion

With the circuits and machine language program described in this paper the user may develop a relatively simple serial output interface to an ASR-33 or RS-232 compatible printers. This circuit can be activated through BASIC or monitor modes. And is a valuable addition to any users program library.



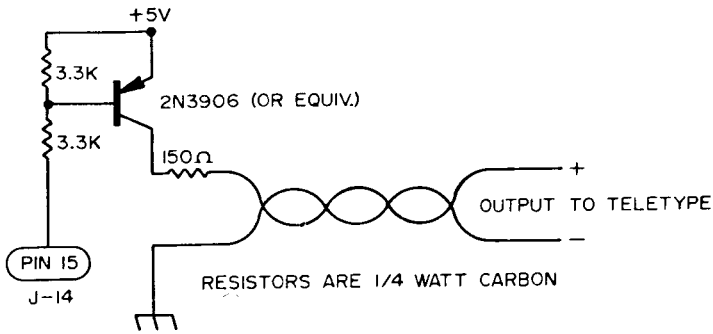

(a)

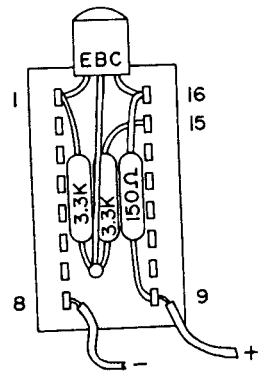

(b)

FIGURE 1 ASR-33

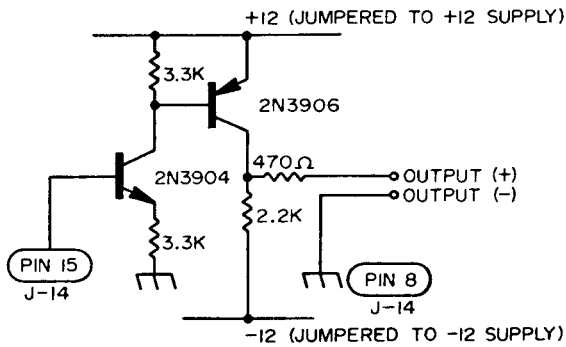

FIGURE 2 RS-232

3:42 P.M., 11/18/1977

```

1  TITLE 'TELETYPE DRIVER ROUTINES'
2  *****
3  *
4  *   TTYDRIVER:
5  *   TELETYPE OUTPUT
6  *   ROUTINE FOR 72
7  *   COLUMN PRINT WITH
8  *   BASIC LIST
9  *
10 *   COPYRIGHT 1977 BY:
11 *   APPLE COMPUTER INC.
12 *   11/18/77
13 *
14 *   R. WIGGINTON
15 *   S. WOZNIAK
16 *
17 *****
18 WNDWDTH EQU $21 ;FOR APPLE-II
19 CH EQU $24 ;CURSOR HORIZ.
20 CSWL EQU $36 ;CHAR. OUT SWITCH
21 YSAVE EQU $778
22 COLCNT EQU $7F8 ;COLUMN COUNT LOC.
23 MARK EQU $C058
24 SPACE EQU $C059
25 WAIT EQU $FCA8
26 ORG $370
***WARNING: OPERAND OVERFLOW IN LINE 27
0370: A9 82 27 TTINIT: LDA #TTOUT ;POINT TO TTY ROUTINES
0372: 85 36 28 STA CSWL ;HIGH BYTE
0374: A9 03 29 LDA #TTOUT/256
0376: 85 37 30 STA CSWL+1
0378: A9 48 31 LDA #72 ;SET WINDOW WIDTH
037A: 85 21 32 STA WNDWDTH ;TO NUMBER COLUMNS ONY
037C: A5 24 33 LDA CH
037E: 8D F8 07 34 STA COLCNT ;WHERE WE ARE NOW.
0381: 60 35 RTS
0382: 48 36 TTOUT: PHA ;SAVE TWICE
0383: 48 37 PHA ;ON STACK.
0384: AD F8 07 38 TTOUT2: LDA COLCNT ;CHECK FOR A TAB.
0387: C5 24 39 CMP CH
0389: 68 40 PLA ;RESTORE OUTPUT CHAR.
038A: B0 03 41 BCS TESTCTRL ;IF C SET, NO TAB
038C: 48 42 PHA
038D: A9 A0 43 LDA #$A0 ;PRINT A SPACE.
038F: 2C C0 03 44 TESTCTRL: BIT RTS1 ;TRICK TO DETERMINE
0392: F0 03 45 BEQ PRNTIT ;IF CONTROL CHAR.
0394: EE F8 07 46 INC COLCNT ;IF NOT, ADD ONE TO CM
0397: 20 C1 03 47 PRNTIT: JSR DOCHAR ;PRINT THE CHAR ON TTY
039A: 68 48 PLA ;RESTORE CHAR
039B: 48 49 PHA ;AND PUT BACK ON STACK
039C: 90 E6 50 BCC TTOUT2 ;DO MORE SPACES FOR TA
039E: 49 OD 51 EOR #$0D ;CHECK FOR CAR RET.
03A0: 0A 52 ASL A ;ELIM PARITY
03A1: D0 OD 53 BNE FINISH ;IF NOT CR, DONE.

```

FIGURE 3a

3:42 P.M., 11/18/1977

03A3:	8D F8 07 54	STA	COLCNT		
03A6:	A9 8A 55	LDA	#38A		;CLEAR COLUMN COUNT
03A8:	20 C1 03 56	JSR	DOCHAR		;NOW DO LINE FEED
03AB:	A9 58 57	LDA	#553		
03AD:	20 A8 FC 58	JSR	WAIT		;200MSEC DELAY FOR LINE
03B0:	AD F8 07 59	FINISH:	LDA	COLCNT	;CHECK IF IN MARGIN
03B3:	F0 08 60		BEQ	SETCH	;FOR CR, RESET CH
03B5:	E5 21 61		SBC	WNDWDTH	;IF SO, CARRY SET.
03B7:	E9 F7 62		SBC	#5F7	
03B9:	90 04 63		BCC	RETURN	
03BB:	69 1F 64		ADC	#51F	;ADJUST CH
03BD:	85 24 65	SETCH:	STA	CH	
03BF:	68 66	RETURN:	PLA		
03C0:	60 67	RTS1:	RTS		;RETURN TO CALLER
	68				* HERE IS THE TELETYPE PRINT A CHARACTER ROUTINE:
03C1:	8C 78 07 69	DOCHAR:	STY	YSAVE	
03C4:	08 70		PHP		;SAVE STATUS.
03C5:	A0 0B 71		LDY	#30B	;11 BITS (1 START, 9
03C7:	18 72		CLC		;BEGIN WITH SPACE (ST
03C8:	48 73	TTOUT3:	PHA		;SAVE A REG AND SET FOR
03C9:	B0 05 74		BCS	MARKOUT	
03CB:	AD 59 C0 75		LDA	SPACE	;SEND A SPACE
03CE:	90 03 76		BCC	TTOUT4	
03D0:	AD 58 C0 77	MARKOUT:	LDA	MARK	;SEND A MARK
03D3:	A9 D7 78	TTOUT4:	LDA	#5D7	;DELAY 9.091 MSEC FOR
03D5:	48 79	DLY1:	PHA		;110 BAUD
03D6:	A9 20 80		LDA	#520	
03D8:	4A 81	DLY2:	LSR	A	
03D9:	90 FD 82		BCC	DLY2	
03DB:	68 83		PLA		
03DC:	E9 01 84		SBC	#501	
03DE:	D0 F5 85		BNE	DLY1	
03E0:	68 86		PLA		
03E1:	6A 87		ROR	A	;NEXT BIT (STOP BITS
03E2:	88 88		DEY		LOOP 11 BITS.
03E3:	D0 E3 89		BNE	TTOUT3	
03E5:	AC 78 07 90		LDY	YSAVE	;RESTORE Y-REG.
03E8:	28 91		PLP		;RESTORE STATUS
03E9:	60 92		RTS		;RETURN

\*\*\*\*\*SUCCESSFUL ASSEMBLY: NO ERRORS

FIGURE 3b

CROSS-REFERENCE: TELETYPE DRIVER ROUTINES

CH	0024	0033	0039	0065
COLCNT	07F8	0034	0038	0046 0054 0059
CSWL	0036	0028	0030	
DLY1	03D5	0085		
DLY2	03D8	0082		
DOCHAR	03C1	0047	0056	
FINISH	03B0	0053		
MARK	C058	0077		
MARKOUT	03D0	0074		
PRNTIT	0397	0045		
RETURN	03BF	0063		
RTS1	03C0	0044		
SETCH	03BD	0060		
SPACE	C059	0075		
TESTCTRL	038F	0041		
TTINIT	0370			
TTOUT	0382	0027	0029	
TTOUT2	0384	0050		
TTOUT3	03C8	0089		
TTOUT4	03D3	0076		
WAIT	FCA8	0058		
WNDWIDTH	0021	0032	0061	
YSAVE	0778	0069	0090	
ILE:				

FIGURE 3c

## INTERFACING THE APPLE

This section defines the connections by which external devices are attached to the APPLE II board. Included are pin diagrams, signal descriptions, loading constraints and other useful information.

### TABLE OF CONTENTS

1. CONNECTOR LOCATION DIAGRAM
2. CASSETTE DATA JACKS (2 EACH)
3. GAME I/O CONNECTOR
4. KEYBOARD CONNECTOR
5. PERIPHERAL CONNECTORS (8 EACH)
6. POWER CONNECTOR
7. SPEAKER CONNECTOR
8. VIDEO OUTPUT JACK
9. AUXILIARY VIDEO OUTPUT CONNECTOR

Figure 1A APPLE II Board-Complete View

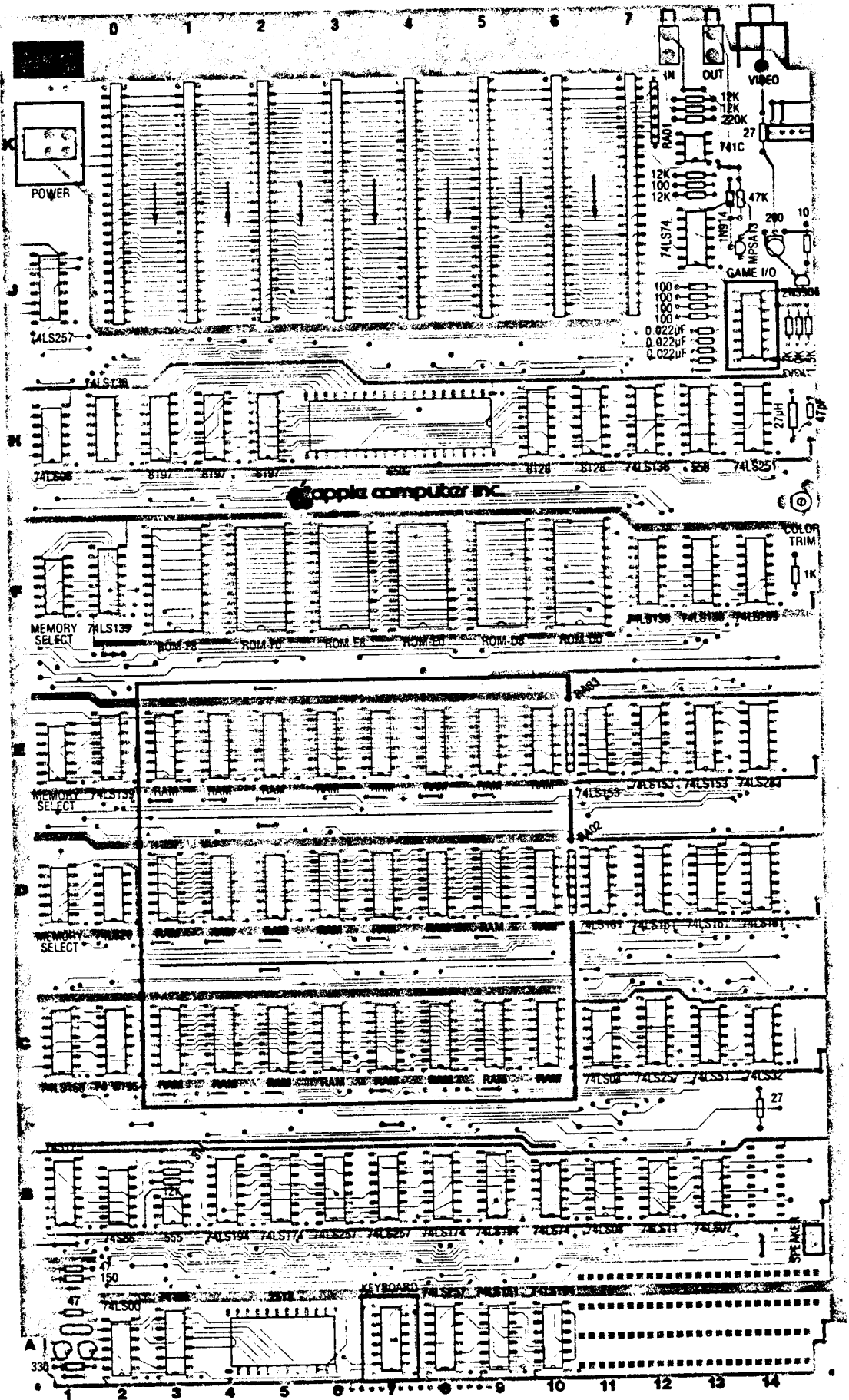
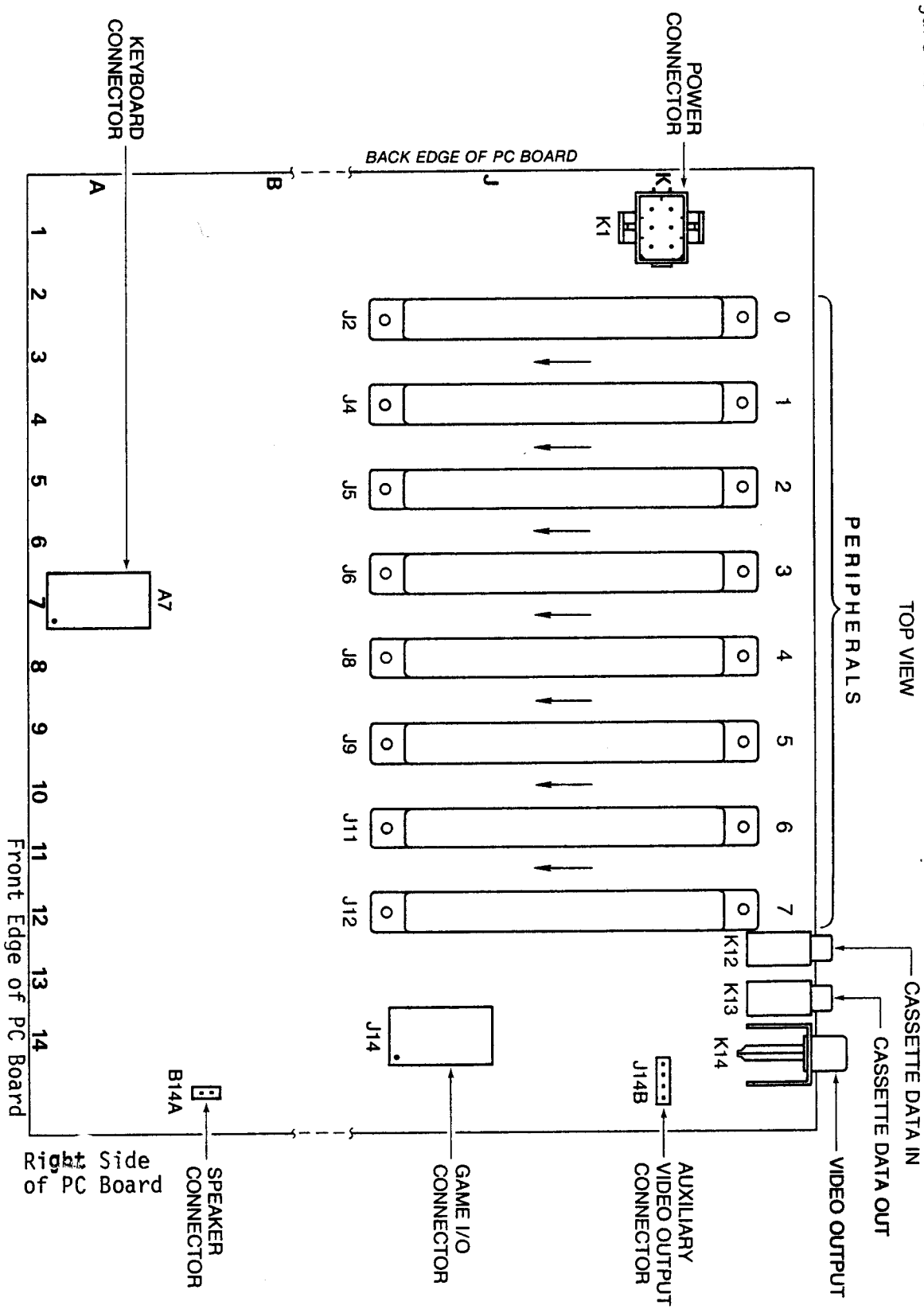

Figure 1B Connector Location Detail

APPLE II PC BOARD  
TOP VIEW



## CASSETTE JACKS

A convenient means for interfacing an inexpensive audio cassette tape recorder to the APPLE II is provided by these two standard (3.5mm) miniature phone jacks located at the back of the APPLE II board.

CASSETTE DATA IN JACK: Designed for connection to the "EARPHONE" or "MONITOR" output found on most audio cassette tape recorders.  $V_{IN}=1V_{pp}$  (nominal),  $Z_{IN}=12K$  Ohms. Located at K12 as illustrated in Figure 1.

CASSETTE DATA OUT JACK: Designed for connection to the "MIC" or "MICROPHONE" input found on most audio cassette tape recorders.  $V_{OUT}=25$  mV into  $100$  Ohms,  $Z_{OUT}=100$  Ohms. Located at K13 as illustrated in Figure 1.

## GAME I/O CONNECTOR

The Game I/O Connector provides a means for connecting paddle controls, lights and switches to the APPLE II for use in controlling video games, etc. It is a 16 pin IC socket located at J14 and is illustrated in Figure 1 and 2.

Figure 2

### GAME I/O CONNECTOR

TOP VIEW  
( Front Edge of PC Board

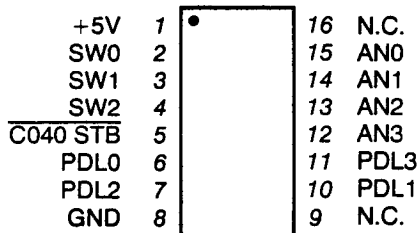

LOCATION J14



## SIGNAL DESCRIPTIONS FOR GAME I/O

AN0-AN3: 8 addresses (C058-C05F) are assigned to selectively "SET" or "CLEAR" these four "ANNUNCIATOR" outputs. Envisioned to control indicator lights, each is a 74LSxx series TTL output and must be buffered if used to drive lamps.

C040 STB: A utility strobe output. Will go low during  $\phi_2$  of a read or write cycle to addresses C040-C04F. This is a 74LSxx series TTL output.

GND: System circuit ground. 0 Volt line from power supply.

NC: No connection.

PDL0-PDL3: Paddle control inputs. Requires a 0-150K ohm variable resistance and +5V for each paddle. Internal 100 ohm resistors are provided in series with external pot to prevent excess current if pot goes completely to zero ohms.

SW0-SW2: Switch inputs. Testable by reading from addresses C061-C063 (or C069-C06B). These are uncommitted 74LSxx series inputs.

+5V: Positive 5-Volt supply. To avoid burning out the connector pin, current drain MUST be less than 100mA.

## KEYBOARD CONNECTOR

This connector provides the means for connecting as ASCII keyboard to the APPLE II board. It is a 16 pin IC socket located at A7 and is illustrated in Figures 1 and 3.

Figure 3      KEYBOARD CONNECTOR

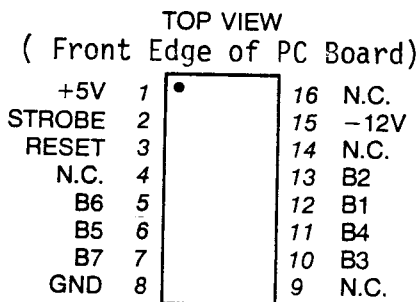

LOCATION A7

## SIGNAL DESCRIPTION FOR KEYBOARD INTERFACE

- B1-B7: 7 bit ASCII data from keyboard, positive logic (high level="1"), TTL logic levels expected.
- GND: System circuit ground.  $\emptyset$  Volt line from power supply.
- NC: No connection.
- RESET: System reset input. Requires switch closure to ground.
- STROBE: Strobe output from keyboard. The APPLE II recognizes the positive going edge of the incoming strobe.
- +5V: Positive 5-Volt supply. To avoid burning out the connector pin, current drain MUST be less than 100mA.
- 12V: Negative 12-Volt supply. Keyboard should draw less than 50mA.

## PERIPHERAL CONNECTORS

The eight Peripheral Connectors mounted near the back edge of the APPLE II board provide a convenient means of connecting expansion hardware and peripheral devices to the APPLE II I/O Bus. These are Winchester #2HW25C0-111 (or equivalent) 50 pin card edge connectors with pins on .10" centers. Location and pin outs are illustrated in Figures 1 and 4.

## SIGNAL DESCRIPTION FOR PERIPHERAL I/O

- A0-A15: 16 bit system address bus. Addresses are set up by the 6502 within 300nS after the beginning of  $\emptyset_1$ . These lines will drive up to a total of 16 standard TTL loads.
- DEVICE SELECT: Sixteen addresses are set aside for each peripheral connector. A read or write to such an address will send pin 41 on the selected connector low during  $\emptyset_2$  (500nS). Each will drive 4 standard TTL loads.
- D0-D7: 8 bit system data bus. During a write cycle data is set up by the 6502 less than 300nS after the beginning of  $\emptyset_2$ . During a read cycle the 6502 expects data to be ready no less than 100nS before the end of  $\emptyset_2$ . These lines will drive up to a total of 8 total low power schottky TTL loads.

- DMA: Direct Memory Access control output. This line has a 3K Ohm pullup to +5V and should be driven with an open collector output.
- DMA IN: Direct Memory Access daisy chain input from higher priority peripheral devices. Will present no more than 4 standard TTL loads to the driving device.
- DMA OUT: Direct Memory Access daisy chain output to lower priority peripheral devices. This line will drive 4 standard TTL loads.
- GND: System circuit ground. 0 Volt line from power supply.
- INH: Inhibit Line. When a device pulls this line low, all ROM's on board are disabled (Hex addressed D000 through FFFF). This line has a 3K Ohm pullup to +5V and should be driven with an open collector output.
- INT IN: Interrupt daisy chain input from higher priority peripheral devices. Will present no more than 4 standard TTL loads to the driving device.
- INT OUT: Interrupt daisy chain output to lower priority peripheral devices. This line will drive 4 standard TTL loads.
- I/O SELECT: 256 addresses are set aside for each peripheral connector (see address map in "MEMORY" section). A read or write of such an address will send pin 1 on the selected connector low during  $\phi_2$  (500nS). This line will drive 4 standard TTL loads.
- I/O STROBE: Pin 20 on all peripheral connectors will go low during  $\phi_2$  of a read or write to any address C800-CFFF. This line will drive a total of 4 standard TTL loads.
- IRQ: Interrupt request line to the 6502. This line has a 3K Ohm pullup to +5V and should be driven with an open collector output. It is active low.
- NC: No connection.
- NMI: Non Maskable Interrupt request line to the 6502. This line has a 3K Ohm pullup to +5V and should be driven with an open collector output. It is active low.
- Q<sub>3</sub>: A 1MHz (nonsymmetrical) general purpose timing signal. Will drive up to a total of 16 standard TTL loads.
- RDY: "Ready" line to the 6502. This line should change only during  $\phi_1$ , and when low will halt the microprocessor at the next READ cycle. This line has a 3K Ohm pullup to +5V and should be driven with an open collector output.
- RES: Reset line from "RESET" key on keyboard. Active low. Will drive 2 MOS loads per Peripheral Connector.

- R/W: READ/WRITE line from 6502. When high indicates that a read cycle is in progress, and when low that a write cycle is in progress. This line will drive up to a total of 16 standard TTL loads.
- USER 1: The function of this line will be described in a later document.
- $\phi_0$ : Microprocessor phase 0 clock. Will drive up to a total of 16 standard TTL loads.
- $\phi_1$ : Phase 1 clock, complement of  $\phi_0$ . Will drive up to a total of 16 standard TTL loads.
- 7M: Seven MHz high frequency clock. Will drive up to a total of 16 standard TTL loads.
- +12V: Positive 12-Volt supply.
- +5V: Positive 5-Volt supply
- 5V: Negative 5-Volt supply.
- 12V: Negative 12-Volt supply.

#### POWER CONNECTOR

The four voltages required by the APPLE II are supplied via this AMP #9-35028-1,6 pin connector. See location and pin out in Figures 1 and 5.

#### PIN DESCRIPTION

- GND: (2 pins) system circuit ground. 0 Volt line from power supply.
- +12V: Positive 12-Volt line from power supply.
- +5V: Positive 5-Volt line from power supply.
- 5V: Negative 5-Volt line from power supply.
- 12V: Negative 5-Volt line from power supply.

Figure 4 PERIPHERAL CONNECTORS  
(EIGHT OF EACH)

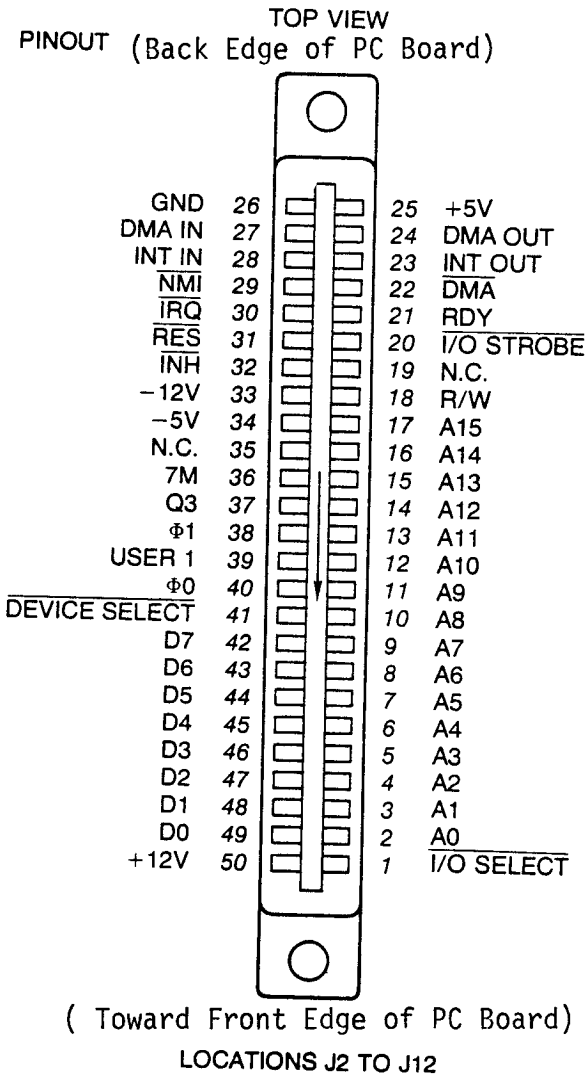
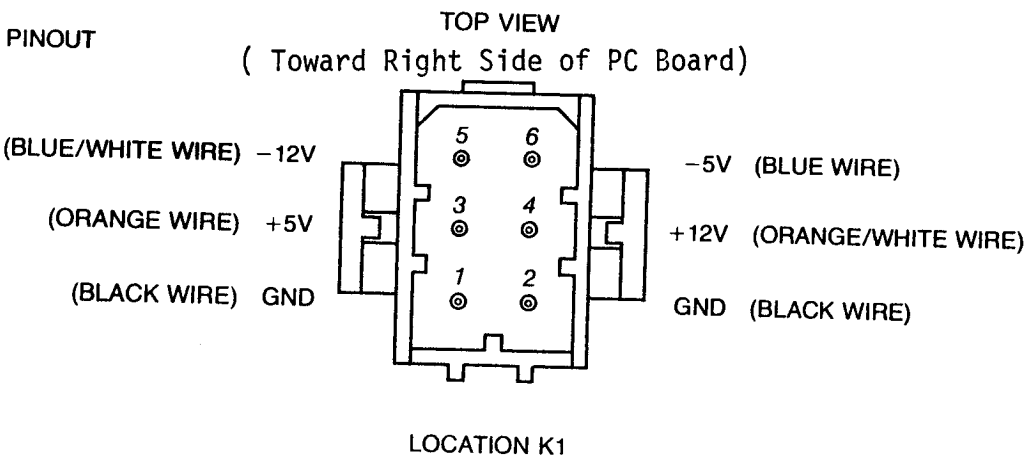

Figure 5 POWER CONNECTOR



## SPEAKER CONNECTOR

This is a MOLEX KK 100 series connector with two .25" square pins on .10" centers. See location and pin out in Figures 1 and 6.

## SIGNAL DESCRIPTION FOR SPEAKER

+5V: System +5 Volts

SPKR: Output line to speaker. Will deliver about .5 watt into 8 Ohms.

Figure 6

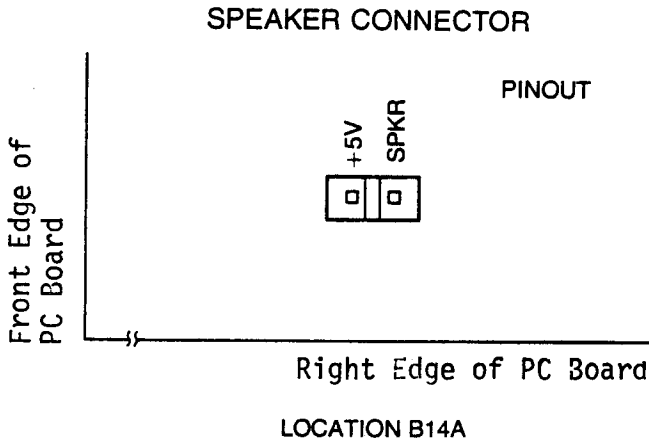

## VIDEO OUTPUT JACK

This standard RCA phono jack located at the back edge of the APPLE II P.C. board will supply NTSC compatible, EIA standard, positive composite video to an external video monitor.

A video level control near the connector allows the output level to be adjusted from 0 to 1 Volt (peak) into an external 75 OHM load.

Additional tint (hue) range is provided by an adjustable trimmer capacitor.

See locations illustrated in Figure 1.

## AUXILIARY VIDEO OUTPUT CONNECTOR

This is a MOLEX KK 100 series connector with four .25" square pins on .10" centers. It provides composite video and two power supply voltages. Video out on this connector is not adjustable by the on board 200 Ohm trim pot. See Figures 1 and 7.

### SIGNAL DESCRIPTION

- GND: System circuit ground. 0 Volt line from power supply.
- VIDEO: NTSC compatible positive composite VIDEO. DC coupled emitter follower output (not short circuit protected). SYNC TIP is 0 Volts, black level is about .75 Volts, and white level is about 2.0 Volts into 470 Ohms. Output level is non-adjustable.
- +12V: +12 Volt line from power supply.
- 5V: -5 Volt line from power supply.

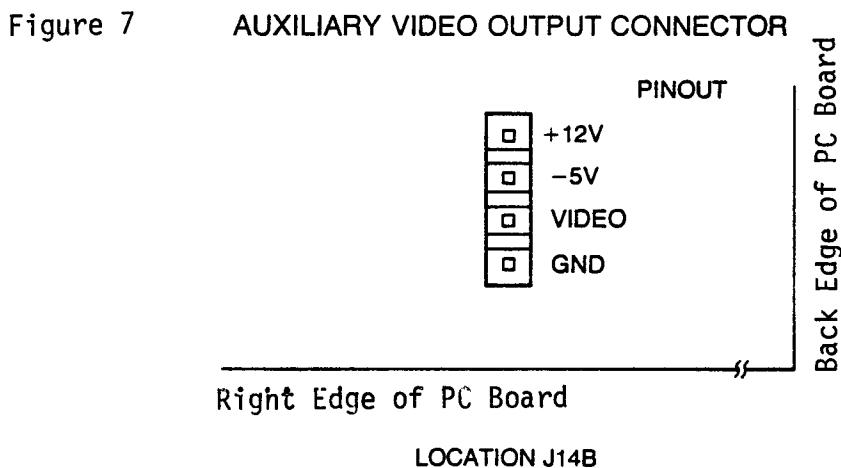

## INSTALLING YOUR OWN RAM

### THE POSSIBILITIES

The APPLE II computer is designed to use dynamic RAM chips organized as 4096 x 1 bit, or 16384 x 1 bit called "4K" and "16K" RAMs respectively. These must be used in sets of 8 to match the system data bus (which is 8 bits wide) and are organized into rows of 8. Thus, each row may contain either 4096 (4K) or 16384 (16K) locations of Random Access Memory depending upon whether 4K or 16K chips are used. If all three rows on the APPLE II board are filled with 4K RAM chips, then 12288 (12K) memory locations will be available for storing programs or data, and if all three rows contain 16K RAM chips then 49152 (commonly called 48K) locations of RAM memory will exist on board!

### RESTRICTIONS

It is quite possible to have the three rows of RAM sockets filled with any combination of 4K RAMs, 16K RAMs or empty as long as certain rules are followed:

1. All sockets in a row must have the same type (4K or 16K) RAMs.
2. There MUST be RAM assigned to the zero block of addresses.

### ASSIGNING RAM

The APPLE II has 48K addresses available for assignment of RAM memory. Since RAM can be installed in increments as small as 4K, a means of selecting which address range each row of memory chips will respond to has been provided by the inclusion of three MEMORY SELECT sockets on board.

Figure 8

#### MEMORY SELECT SOCKETS

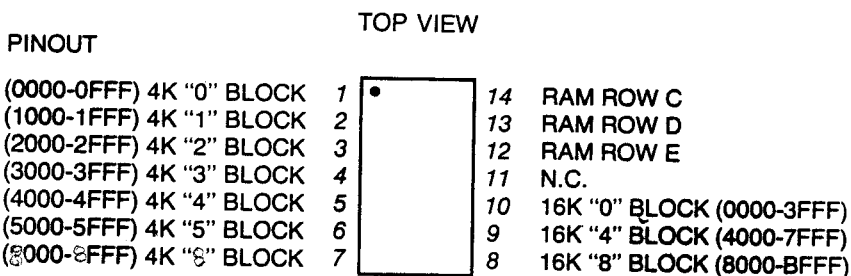

LOCATIONS D1, E1, F1



TABLE OF CONTENTS

1. INTRODUCTION
2. INSTALLING YOUR OWN RAM
3. MEMORY SELECT SOCKETS
4. MEMORY MAP BY 4K BLOCKS
5. DETAILED MAP OF ASSIGNED ADDRESSES

INTRODUCTION

APPLE II is supplied completely tested with the specified amount of RAM memory and correct memory select jumpers. There are five different sets of standard memory jumper blocks:

1. 4K 4K 4K BASIC
2. 4K 4K 4K HIRES
3. 16K 4K 4K
4. 16K 16K 4K
5. 16K 16K 16K

A set of three each of one of the above is supplied with the board. Type 1 is supplied with 4K or 8K systems. Both type 1 and 2 are supplied with 12K systems. Type 1 is a contiguous memory range for maximum BASIC program size. Type 2 is non-contiguous and allows 8K dedicated to HIRES screen memory with approximately 2K of user BASIC space. Type 3 is supplied with 16K, 20K and 24K systems. Type 4 with 30K and 36K systems and type 5 with 48K systems.

Additional memory may easily be added just by plugging into sockets along with correct memory jumper blocks.

The 6502 microprocessor generates a 16 bit address, which allows 65536 (commonly called 65K) different memory locations to be specified. For convenience we represent each 16 bit (binary) address as a 4-digit hexadecimal number. Hexadecimal notation (hex) is explained in the Monitor section of this manual.

In the APPLE II, certain address ranges have been assigned to RAM memory, ROM memory, the I/O bus, and hardware functions. The memory and address maps give the details.

## MEMORY SELECT SOCKETS

The location and pin out for memory select sockets are illustrated in Figures 1 and 8.

### HOW TO USE

There are three MEMORY SELECT sockets, located at D1, E1 and F1 respectively. RAM memory is assigned to various address ranges by inserting jumper wires as described below. All three MEMORY SELECT sockets MUST be jumpered identically! The easiest way to do this is to use Apple supplied memory blocks.

Let us learn by example:

If you have plugged 16K RAMs into row "C" (the sockets located at C3-C10 on the board), and you want them to occupy the first 16K of addresses starting at 0000, jumper pin 14 to pin 10 on all three MEMORY SELECT sockets (thereby assigning row "C" to the 0000-3FFF range of memory).

If in addition you have inserted 4K RAMs into rows "D" and "E", and you want them each to occupy the first 4K addresses starting at 4000 and 5000 respectively, jumper pin 13 to pin 5 (thereby assigning row "D" to the 4000-4FFF range of memory), and jumper pin 12 to pin 6 (thereby assigning row "E" to the 5000-5FFF range of memory). Remember to jumper all three MEMORY SELECT sockets the same.

Now you have a large contiguous range of addresses filled with RAM memory. This is the 24K addresses from 0000-5FFF.

By following the above examples you should be able to assign each row of RAM to any address range allowed on the MEMORY SELECT sockets. Remember that to do this properly you must know three things:

1. Which rows have RAM installed?
2. Which address ranges do you want them to occupy?
3. Jumper all three MEMORY SELECT sockets the same!

If you are not sure think carefully, essentially all the necessary information is given above.

# Memory Address Allocations in 4K Bytes

0000	text and color graphics display pages, 6502 stack, pointers, etc.	8000	
1000		9000	
2000	high res graphics display primary page	A000	
3000	"	B000	
4000	high res. graphics display secondary page	C000	addresses dedicated to hardware functions
5000	"	D000	ROM socket D0: spare
6000	"	E000	ROM socket D8: spare
7000	"	F000	ROM socket E0: BASIC
			ROM socket E8: BASIC
			ROM socket F0: BASIC utility
			ROM socket F8: monitor

## Memory Map Pages 0 to BFF

HEX ADDRESS(ES)	USED BY	USED FOR	COMMENTS
<u>PAGE ZERO</u> 0000-001F	UTILITY	register area for "sweet 16" 16 bit firmware processor.	
0020-004D	MONITOR		
004E-004F	MONITOR	holds a 16 bit number that is randomized with each key entry.	
0050-0055	UTILITY	integer multiply and divide work space.	
0055-00FF	BASIC		
00FC- 00FF	UTILITY	floating point work space.	
<u>PAGE ONE</u> 0100-01FF	6502	subroutine return stack.	
<u>PAGE TWO</u> 0200-02FF		character input buffer.	
<u>PAGE THREE</u> 03FB	MONITOR	Y (control Y) will cause a CSR to this location.	
03FB		NMI's are vectored to this location.	
03FE-03FF		IRQ's are vectored to the address pointed to by these locations.	
0400-07FF	DISPLAY	text or color graphics primary page.	
0800-0BFF	DISPLAY	text or color graphics secondary page.	BASIC initializes LOWEM to location 0800.

## I/O and ROM Address Detail

HEX ADDRESS	ASSIGNED FUNCTION	COMMENTS
C00X	Keyboard input.	Keyboard strobe appears in bit 7. ASCII data from keyboard appears in the 7 lower bits.
C01X	Clear keyboard strobe.	
C02X	Toggle cassette output.	
C03X	Toggle speaker output.	
C04X	" <u>C040</u> STB"	Output strobe to Game I/O connector.
C050	Set graphics mode	
C051	" text "	
C052	Set bottom 4 lines graphics	
C053	" " " " text	
C054	Display primary page	
C055	" secondary page	
C056	Set high res. graphics	
C057	" color "	
C058	Clear "AN0"	Annunciator 0 output to Game I/O connector.
C059	Set "	
C05A	Clear "AN1"	Annunciator 1 output to Game I/O connector.
C05B	Set "	
C05C	Clear "AN2"	Annunciator 2 output to Game I/O connector.
C05D	Set "	
C05E	Clear "AN3"	Annunciator 3 output to Game I/O connector.
C05F	Set "	

HEX ADDRESS	ASSIGNED FUNCTION	COMMENTS
C060/8	Cassette input	State of "Cassette Data In" appears in bit 7.
C061/9	"SW1"	input on State of Switch 1 $\wedge$ Game I/O connector appears in bit 7.
C062/A	"SW2"	State of Switch 2 input on Game I/O connector appears in bit 7.
C063/B	"SW3"	State of Switch 3 input on Game I/O connector appears in bit 7.
C064/C	Paddle 0 timer output	State of timer output for Paddle 0 appears in bit 7.
C065/D	" 1 "	State of timer output for Paddle 1 appears in bit 7.
C066/E	" 2 "	State of timer output for Paddle 2 appears in bit 7.
C067/F	" 3 "	State of timer output for Paddle 3 appears in bit 7.
C07X	" <u>PDL STB</u> "	Triggers paddle timers during $\phi_2$ .
C08X	<u>DEVICE SELECT</u> 0	Pin 41 on the selected Peripheral Connector goes low during $\phi_2$ .
C09X	" 1	
COAX	" 2	
COBX	" 3	
COCX	" 4	
CODX	" 5	
COEX	" 6	
COFX	" 7	
C10X	" 8	
C11X	" 9	
C12X	" A	Expansion connectors.

HEX ADDRESS	ASSIGNED FUNCTION	COMMENTS
C13X	<u>DEVICE SELECT</u> B	"
C14X	" C	"
C15X	" D	"
C16X	" E	"
C17X	" F	"
C1XX	<u>I/O SELECT</u> 1	Pin 1 on the selected Peripheral Connector goes low during $\phi_2$ .
C2XX	" 2	
C3XX	" 3	NOTES:
C4XX	" 4	1. Peripheral Connector 0 does not get this signal.
C5XX	" 5	2. <u>I/O SELECT</u> 1 uses the same addresses as <u>DEVICE SELECT</u> 8-F.
C6XX	" 6	
C7XX	" 7	
C8XX	" 8, <u>I/O STROBE</u>	Expansion connectors.
C9XX	" 9, "	
CAXX	" A, "	
CBXX	" B, "	
CCXX	" C, "	
CDXX	" D, "	
CEXX	" E, "	
CFXX	" F, "	
D000-D7FF	ROM socket D0	Spare.
D800-DFFF	" " D8	Spare.
E000-E7FF	" " E0	BASIC.
E800-EFFF	" " E8	BASIC.
F000-F7FF	" " F0	1K of BASIC, 1K of utility.
F800-FFFF	" " F8	Monitor.

# SYSTEM TIMING

## SIGNAL DESCRIPTIONS

- 14M: Master oscillator output, 14.318 MHz +/- 35 ppm. All other timing signals are derived from this one.
- 7M: Intermediate timing signal, 7.159 MHz.
- COLOR REF: Color reference frequency used by video circuitry, 3.580 MHz.
- $\Phi_0$ : Phase  $\Phi$  clock to microprocessor, 1.023 MHz nominal.
- $\Phi_1$ : Microprocessor phase 1 clock, complement of  $\Phi_0$ , 1.023 MHz nominal.
- $\Phi_2$ : Same as  $\Phi_0$ . Included here because the 6502 hardware and programming manuals use the designation  $\Phi_2$  instead of  $\Phi_0$ .
- Q3: A general purpose timing signal which occurs at the same rate as the microprocessor clocks but is nonsymmetrical.

## MICROPROCESSOR OPERATIONS

- ADDRESS: The address from the microprocessor changes during  $\Phi_1$ , and is stable about 300nS after the start of  $\Phi_1$ .
- DATA WRITE: During a write cycle, data from the microprocessor appears on the data bus during  $\Phi_2$ , and is stable about 300nS after the start of  $\Phi_2$ .
- DATA READ: During a read cycle, the microprocessor will expect data to appear on the data bus no less than 100nS prior to the end of  $\Phi_2$ .

## SYSTEM TIMING DIAGRAM

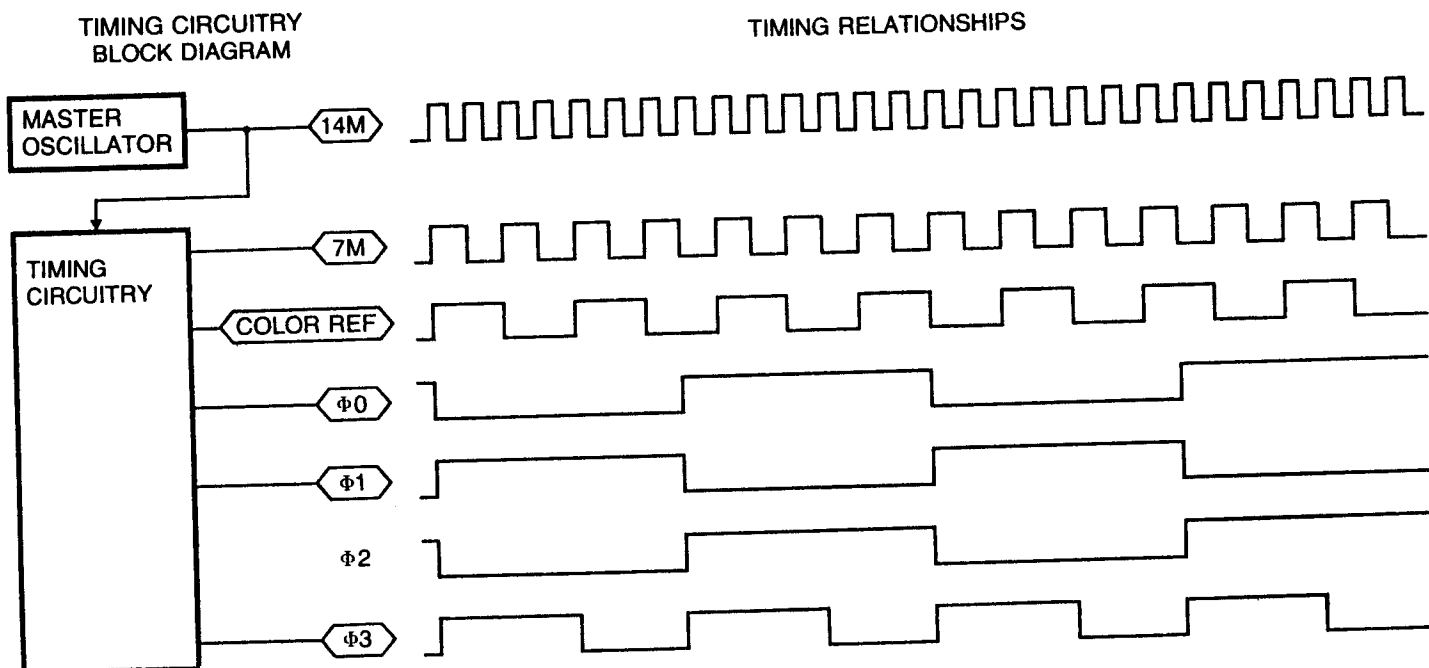

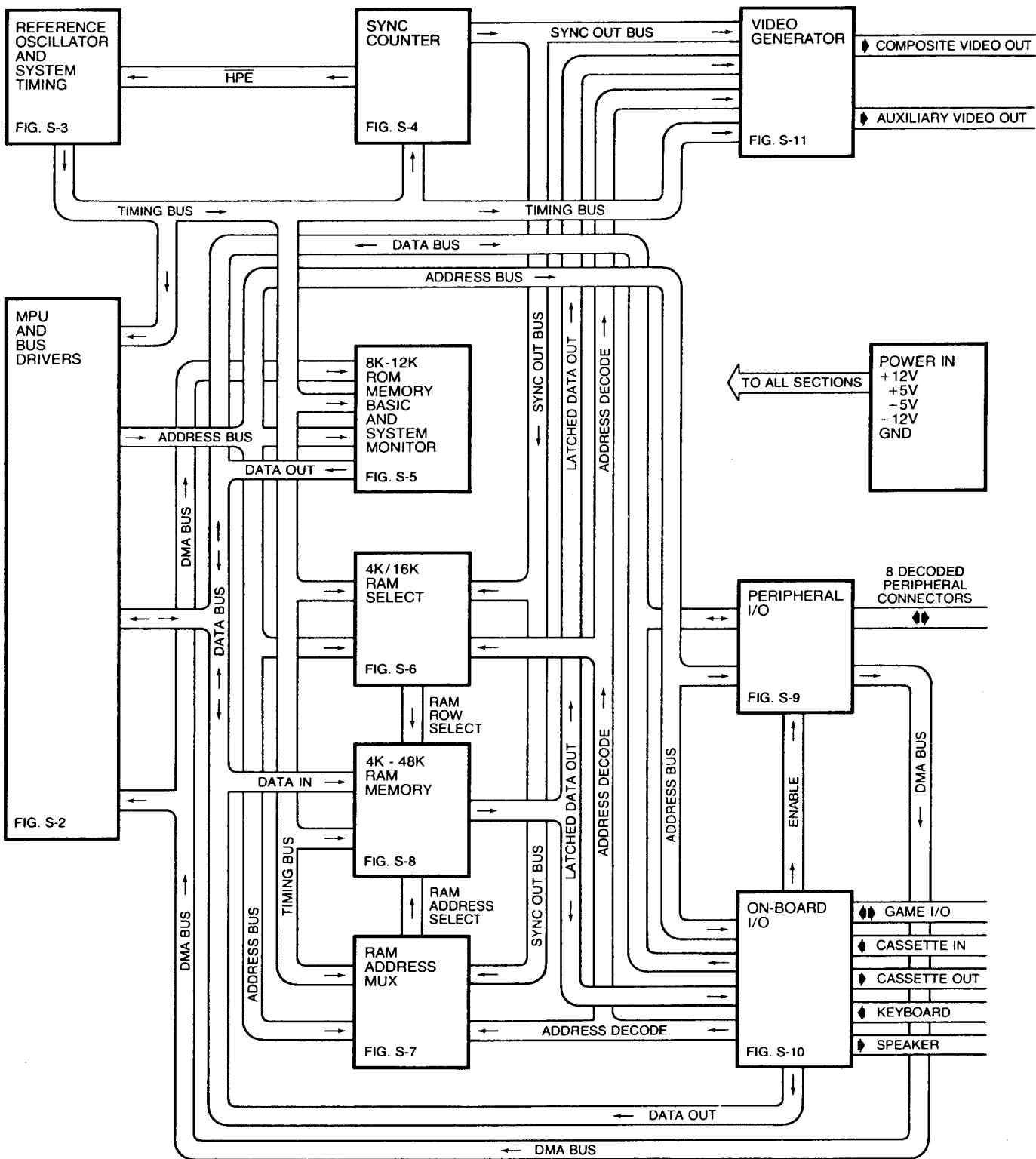

FIGURE S-1 APPLE II SYSTEM DIAGRAM



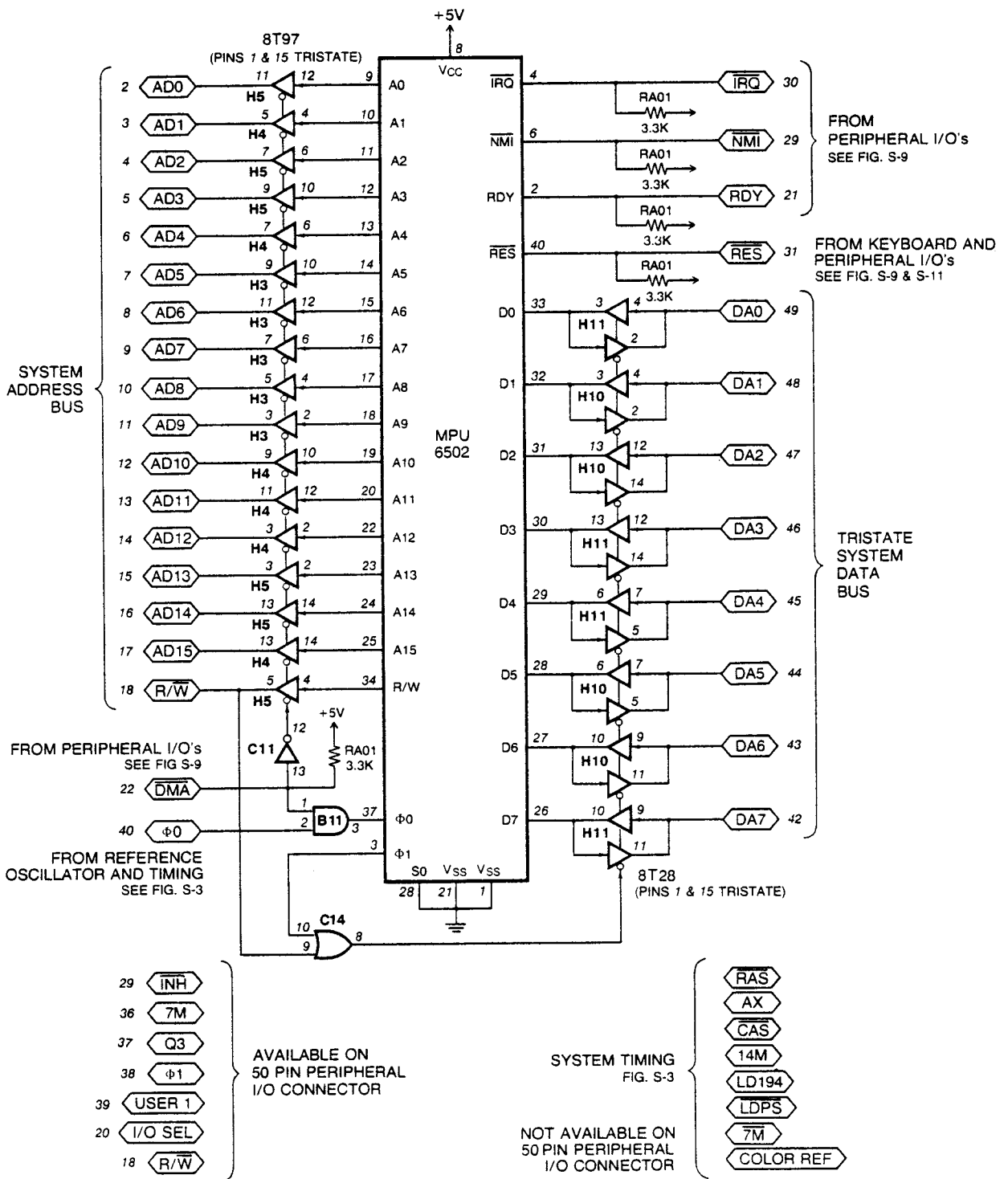

FIGURE S-2 MPU AND SYSTEM BUS

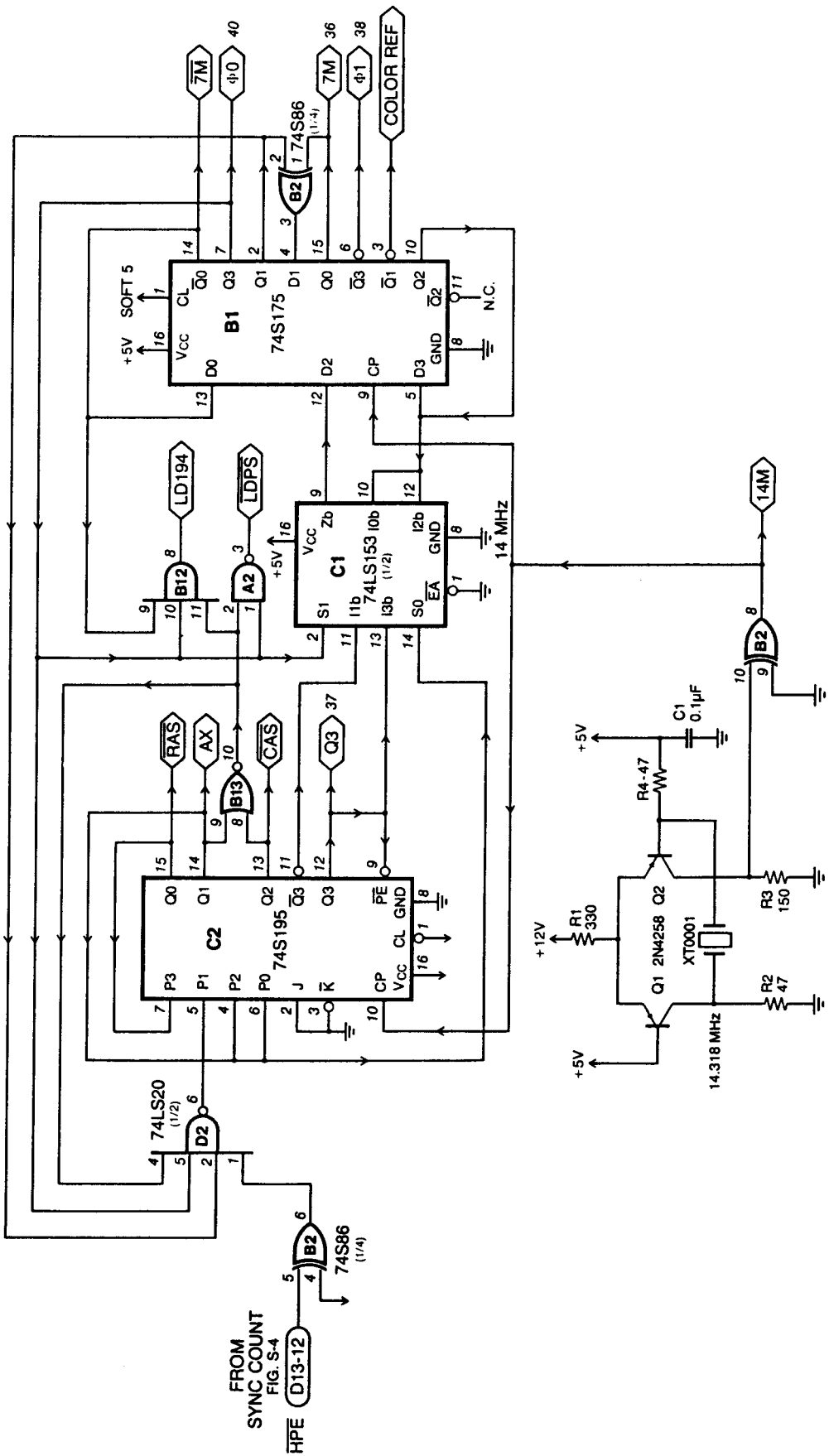

FIGURE S-3 REFERENCE OSCILLATOR AND SYSTEM TIMING

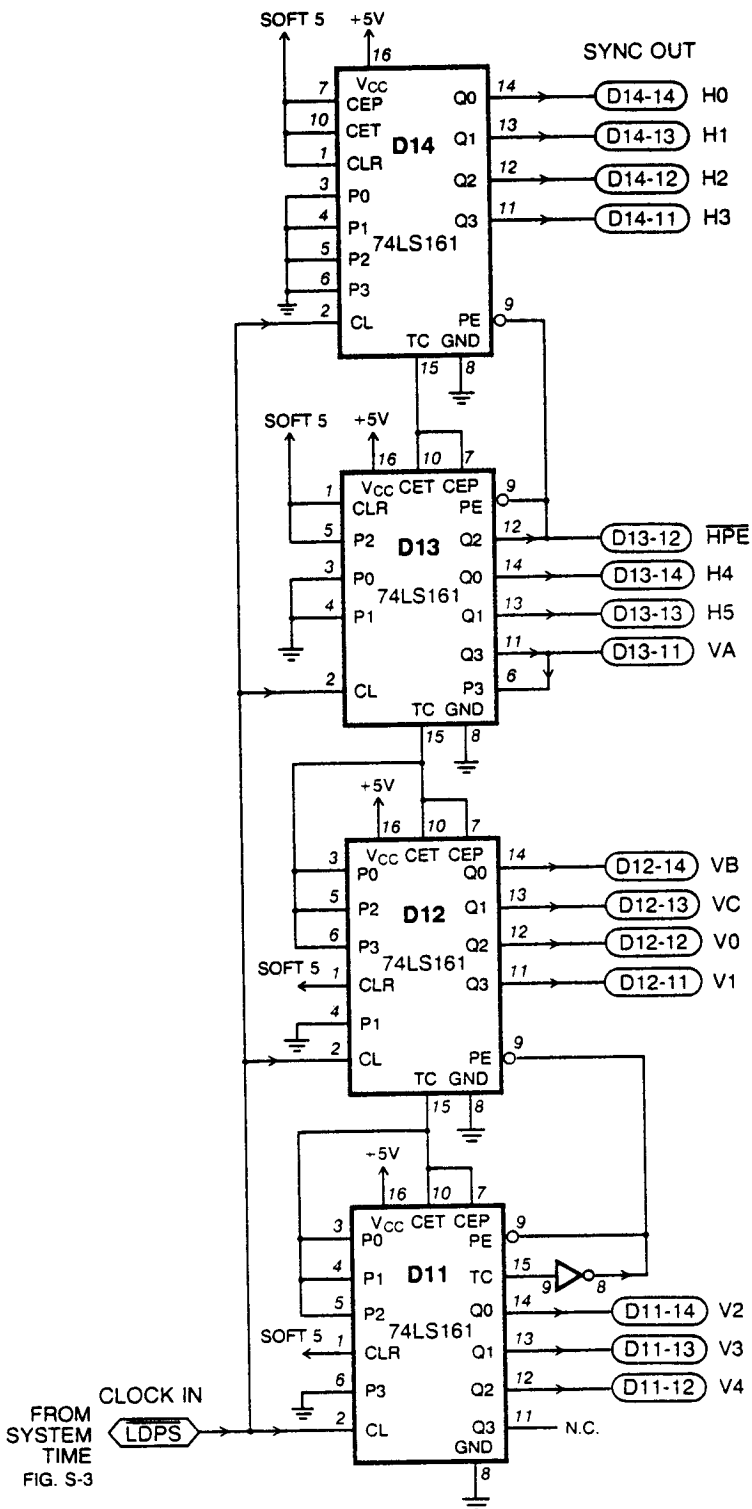

FIGURE S-4 SYNC COUNTER

ROM PINOUT DETAIL

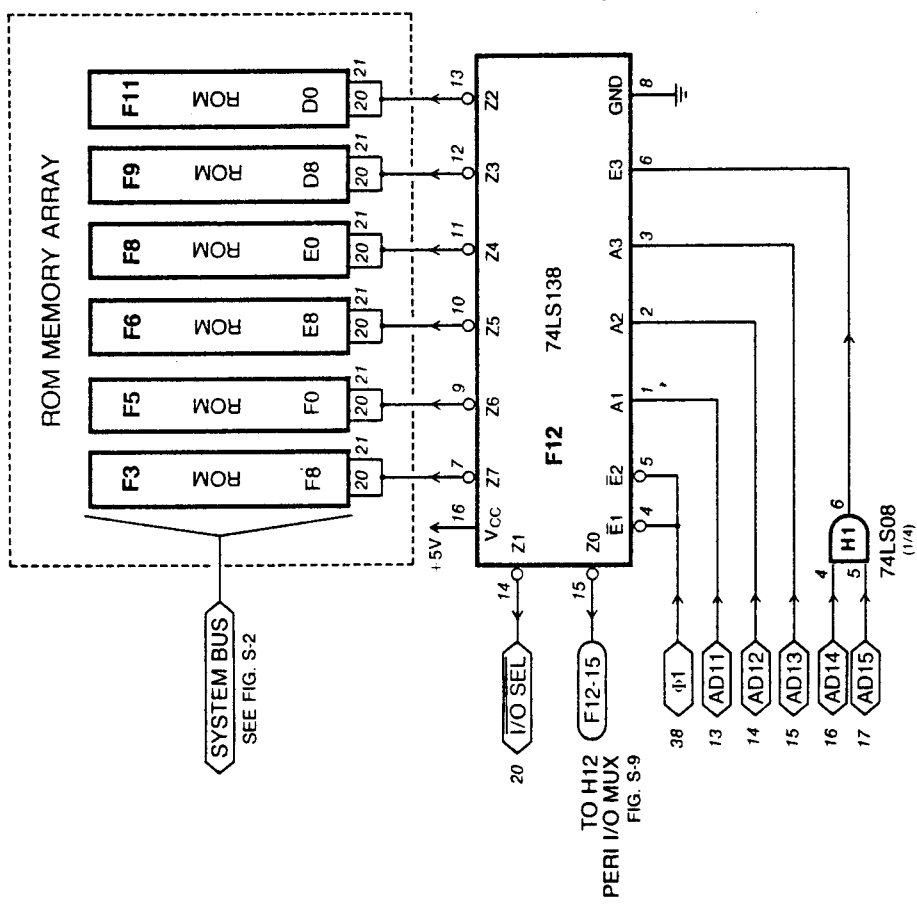
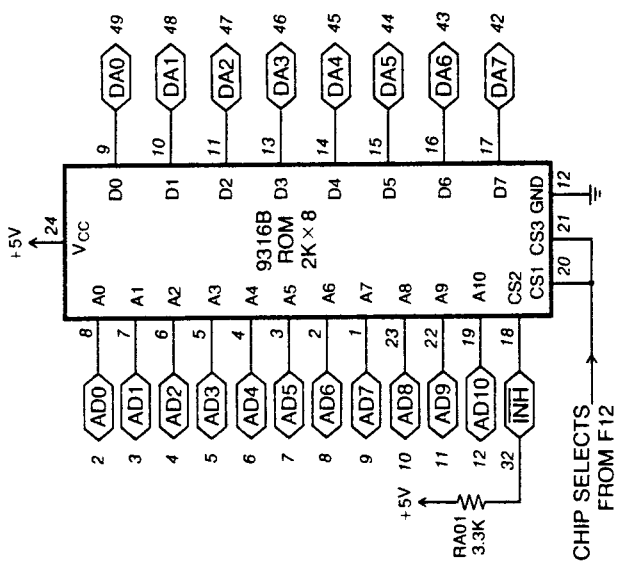

FIGURE S-5 ROM MEMORY

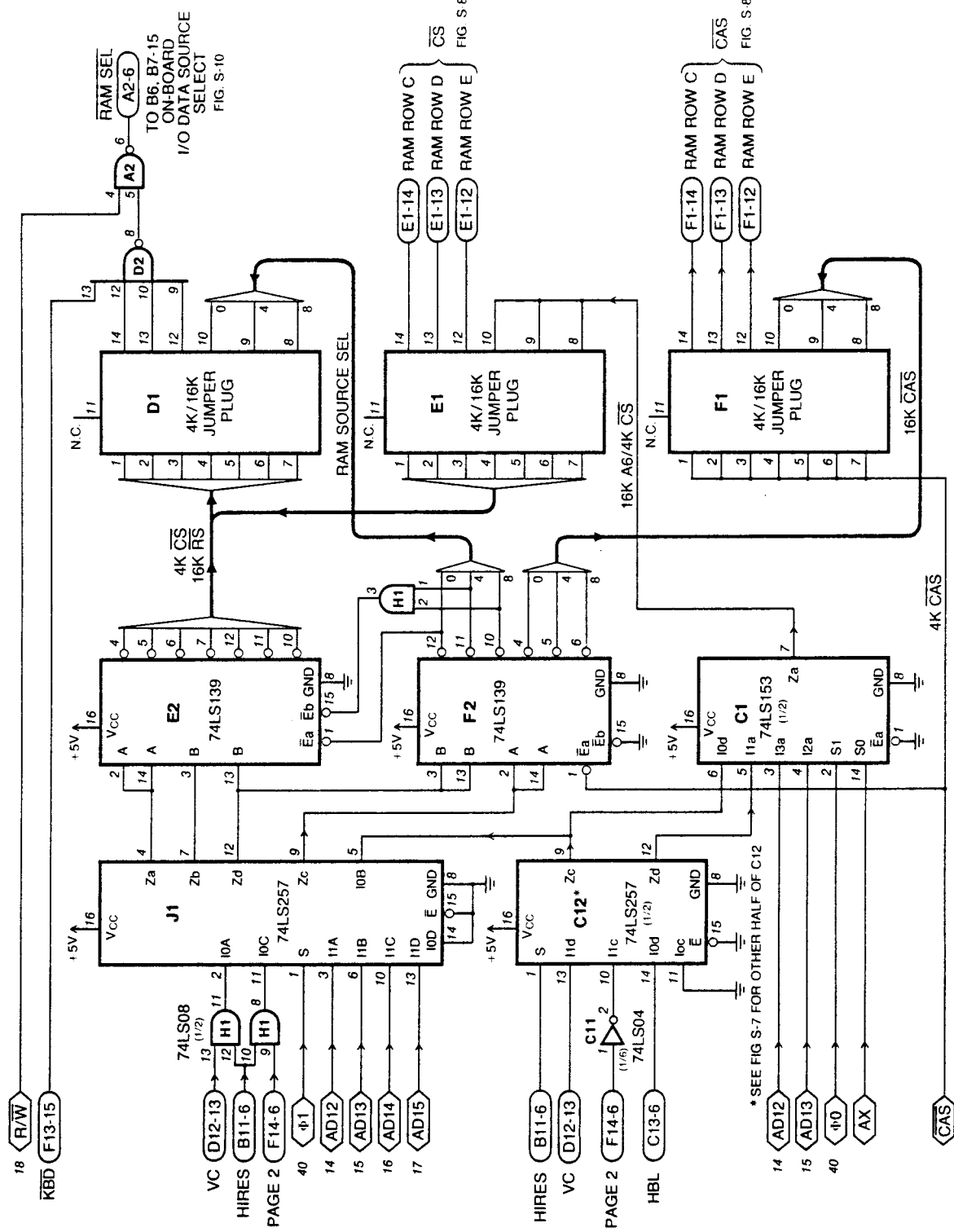

FIGURE S-6 4K/16K RAM SELECT

"D" SOURCES ARE FROM SYNC COUNT  
FIG. S-4

SCREEN ADDRESS FROM SYNC COUNT  
FIG. S-4

TO RAM ADDRESS LINES  
FIG. S-8

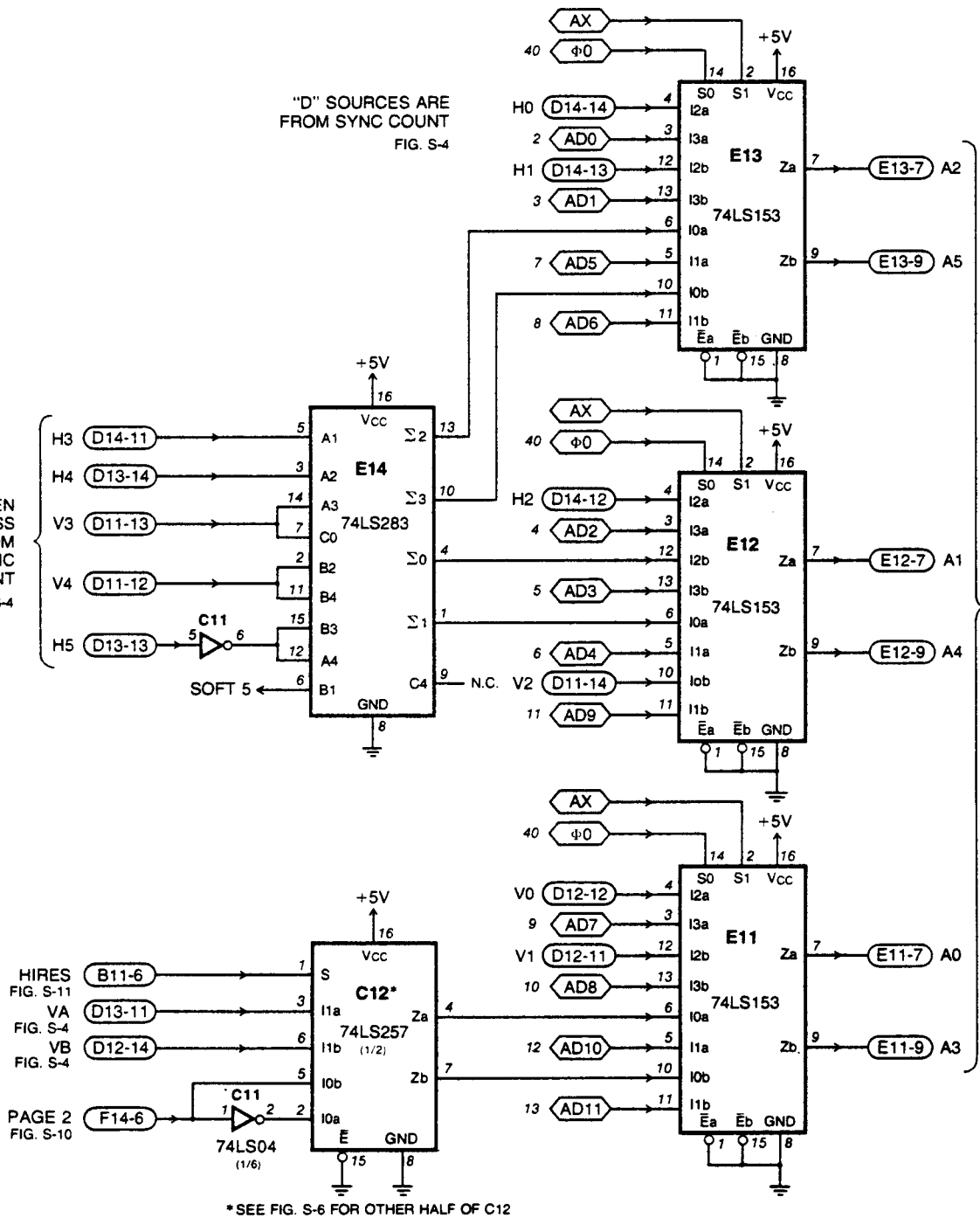

FIGURE S-7 RAM ADDRESS MUX

FROM 4K/16K SELECT  
FIG. S-6

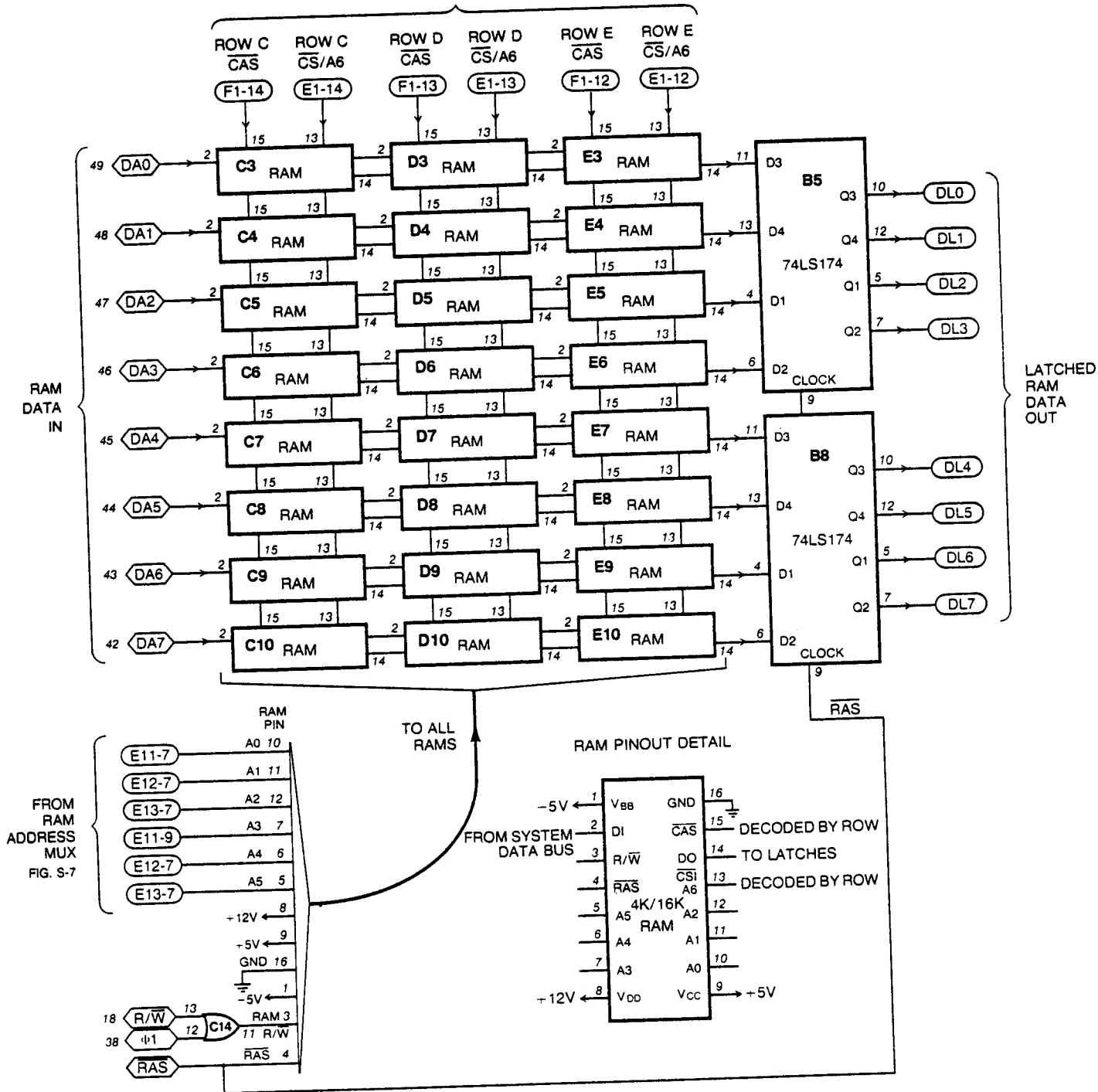

FIGURE S-8 4K TO 48K RAM MEMORY WITH DATA LATCH

I/O CONNECTOR DETAIL

TOP VIEW

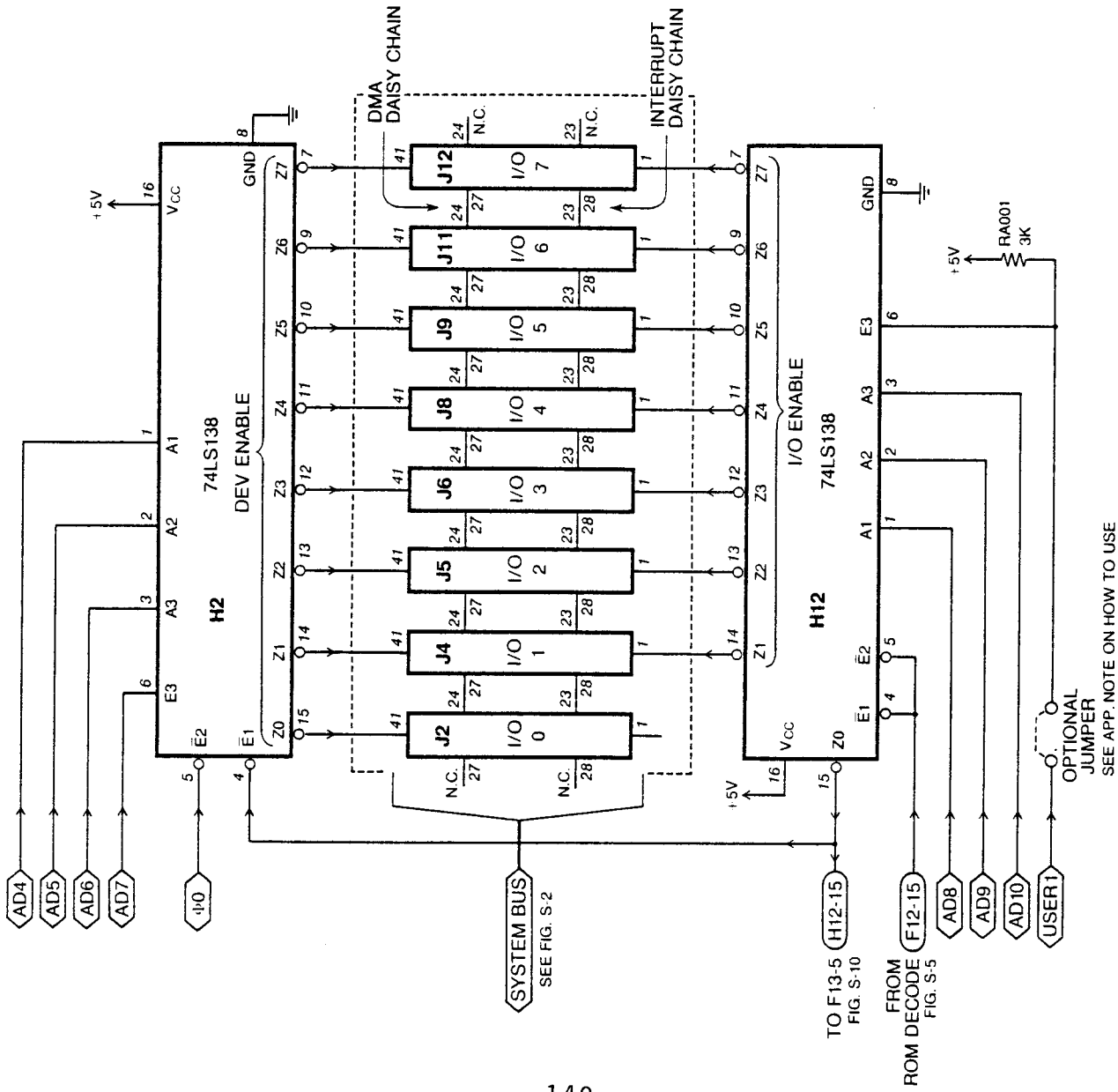
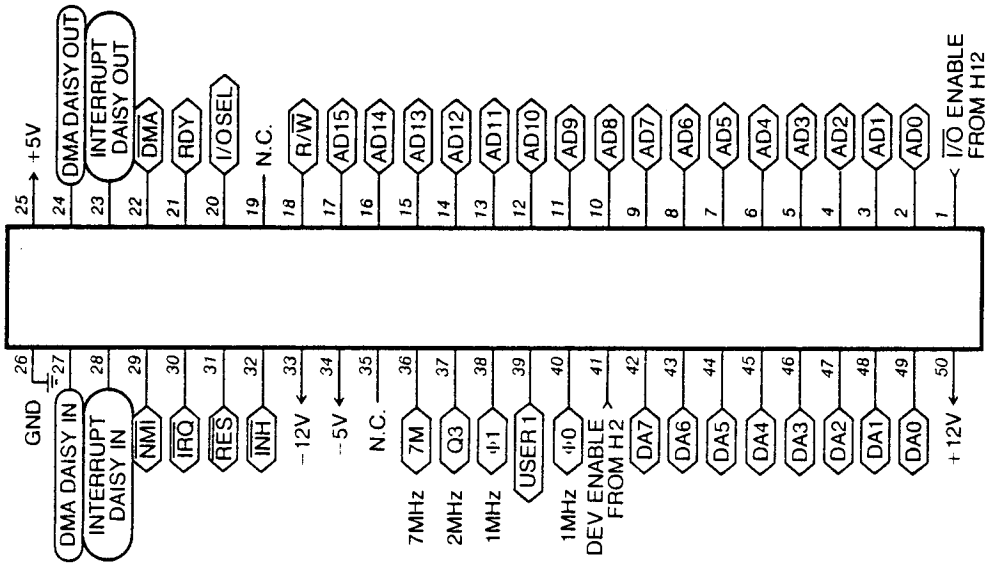

FIGURE S-9 PERIPHERAL I/O CONNECTOR PINOUT AND CONTROL LOGIC



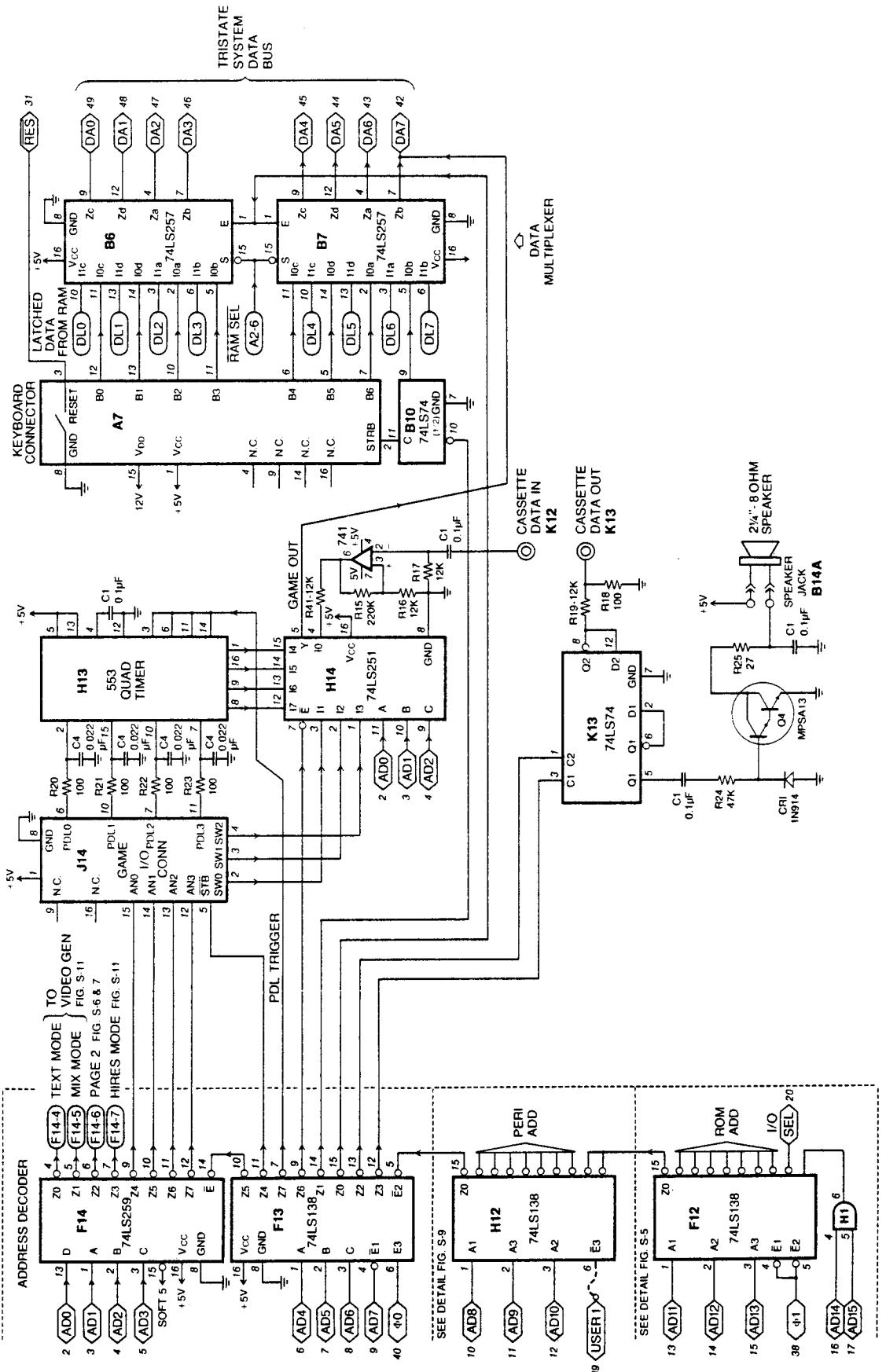

FIGURE S-10 ON-BOARD I/O

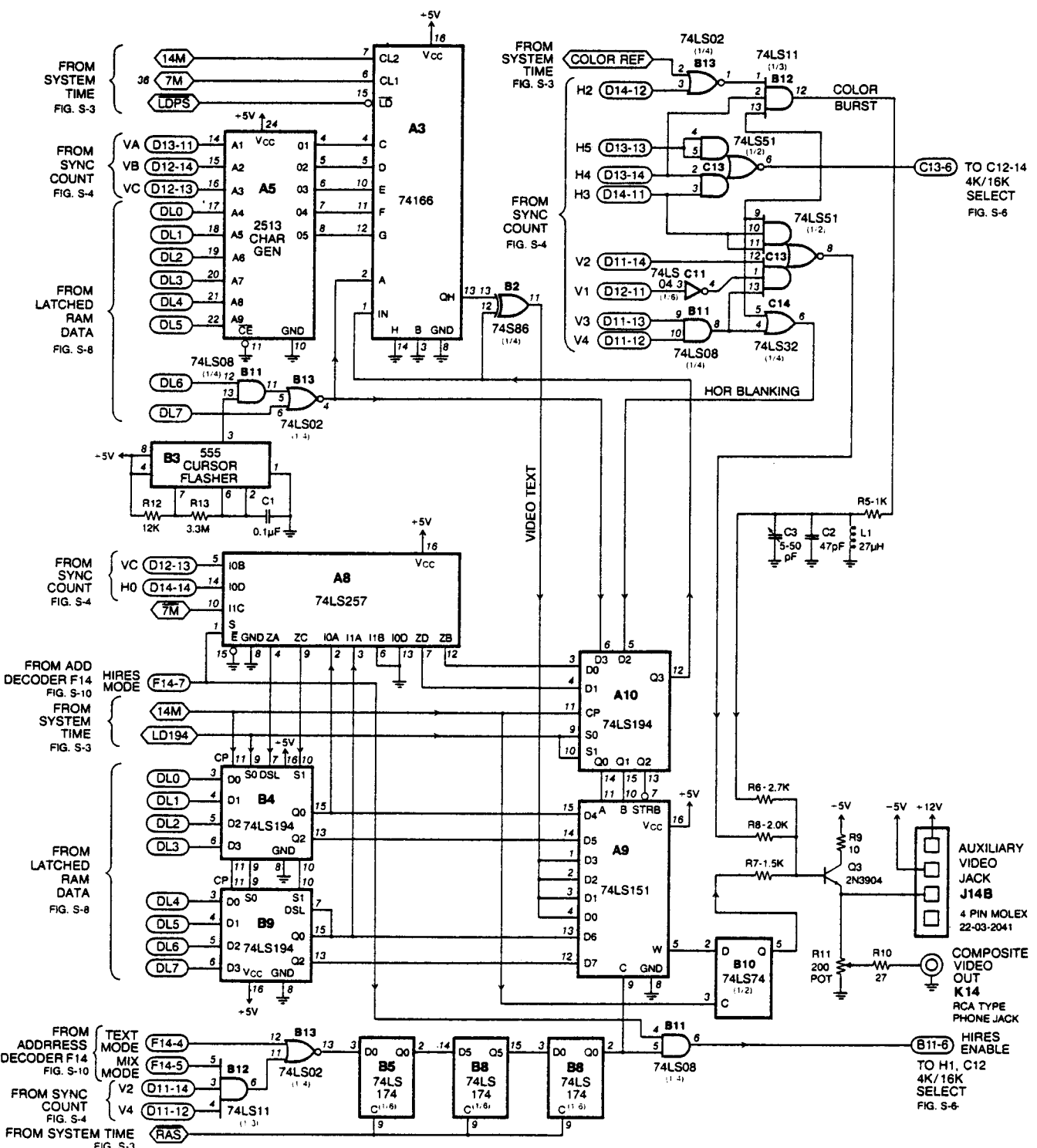

FIGURE S-11 VIDEO GENERATOR



10260 BANDLEY DRIVE  
CUPERTINO, CALIFORNIA 95014 U.S.A.  
TELEPHONE (408) 996-1010